

# Best Buy NoHo

622 BROADWAY  
NEW YORK, NY 10012

ROOFTOP HVAC EQUIPMENT REPLACEMENT  
AND ACOUSTIC BARRIERS

prepared by

**BW**Architects

611 BROADWAY, SUITE 311, NEW YORK, NY 10012





# EXISTING CONDITIONS



SITE PLAN

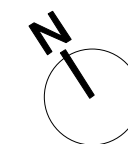

# EXISTING CONDITIONS

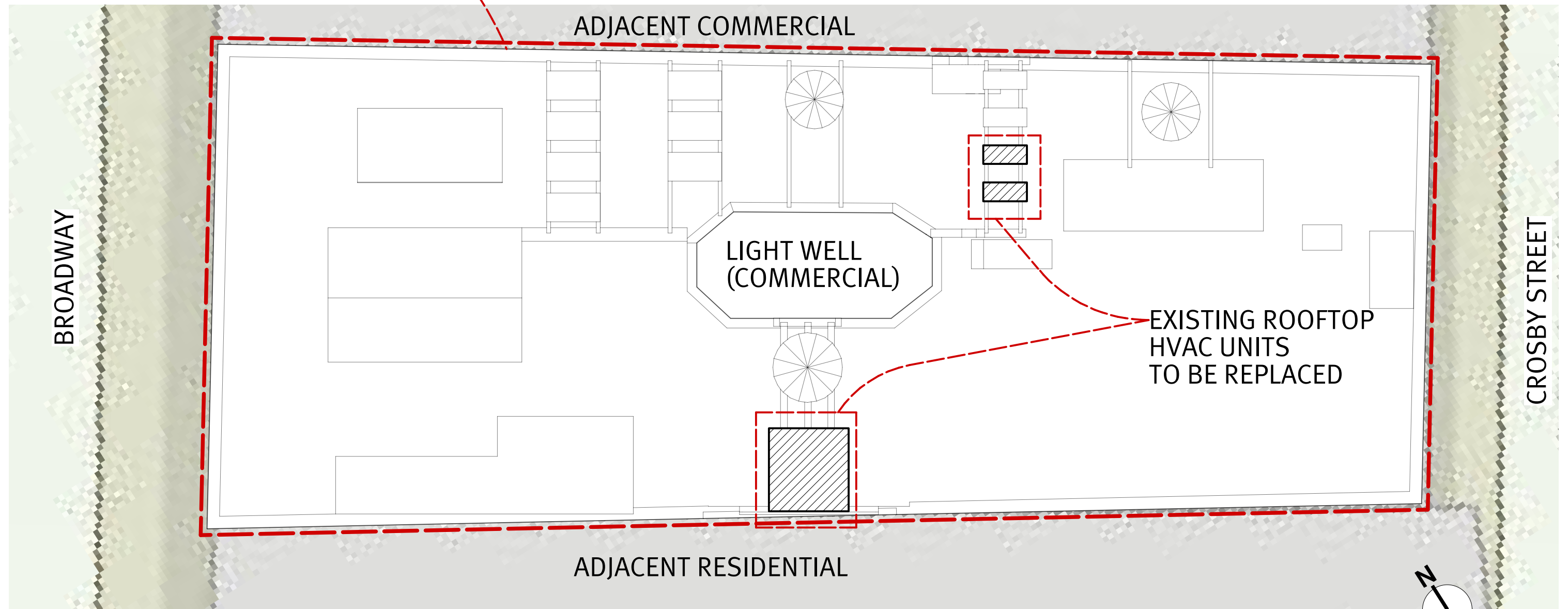
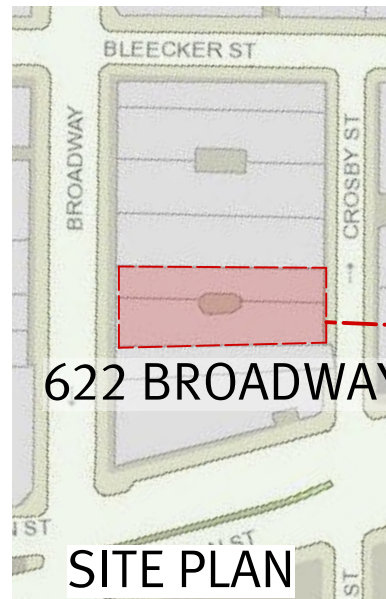

ROOF PLAN



# EXISTING CONDITIONS



NORTH - CONDENSING UNITS



SOUTH - CHILLER UNIT

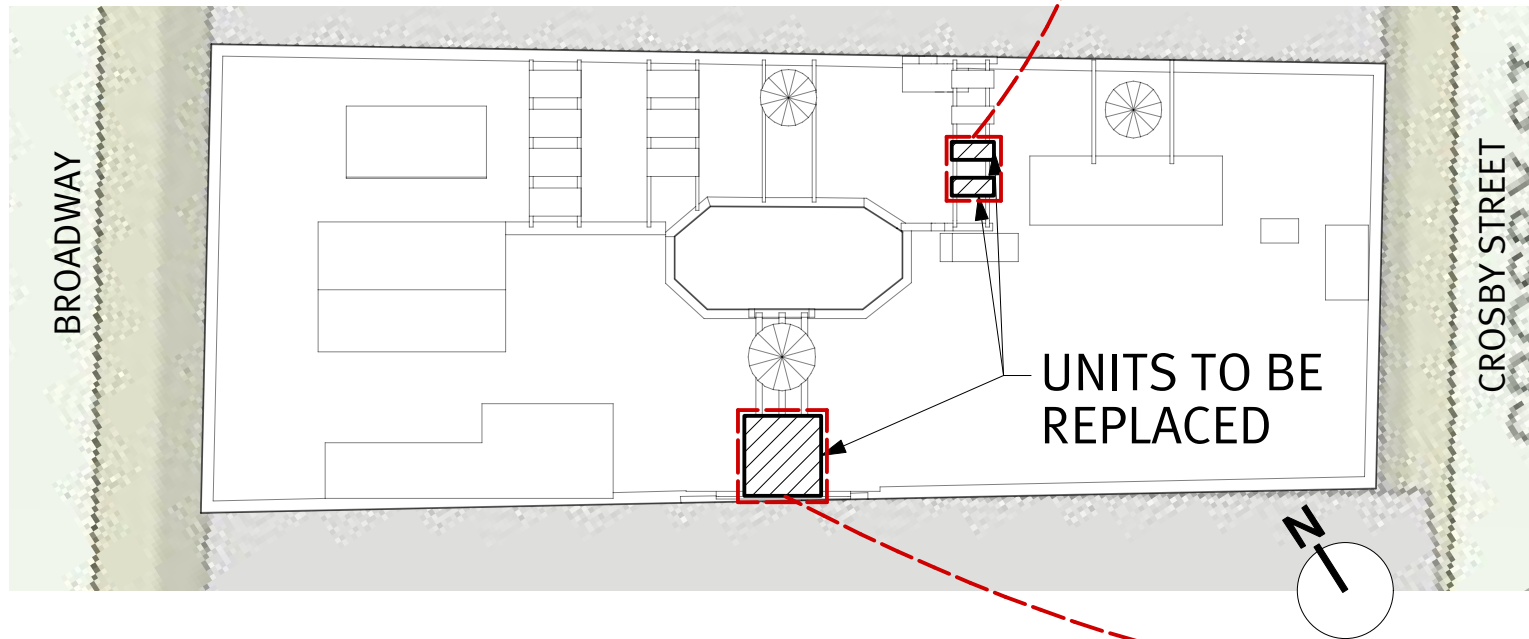

ROOF PLAN



**PROPOSED**



PER NYC NOISE CONTROL CODE, ALL NEW UNITS MUST CONTRAIN SOUND TRANSMISSION TO ADJACENT RESIDENTIAL OR COMMERCIAL UNITS.

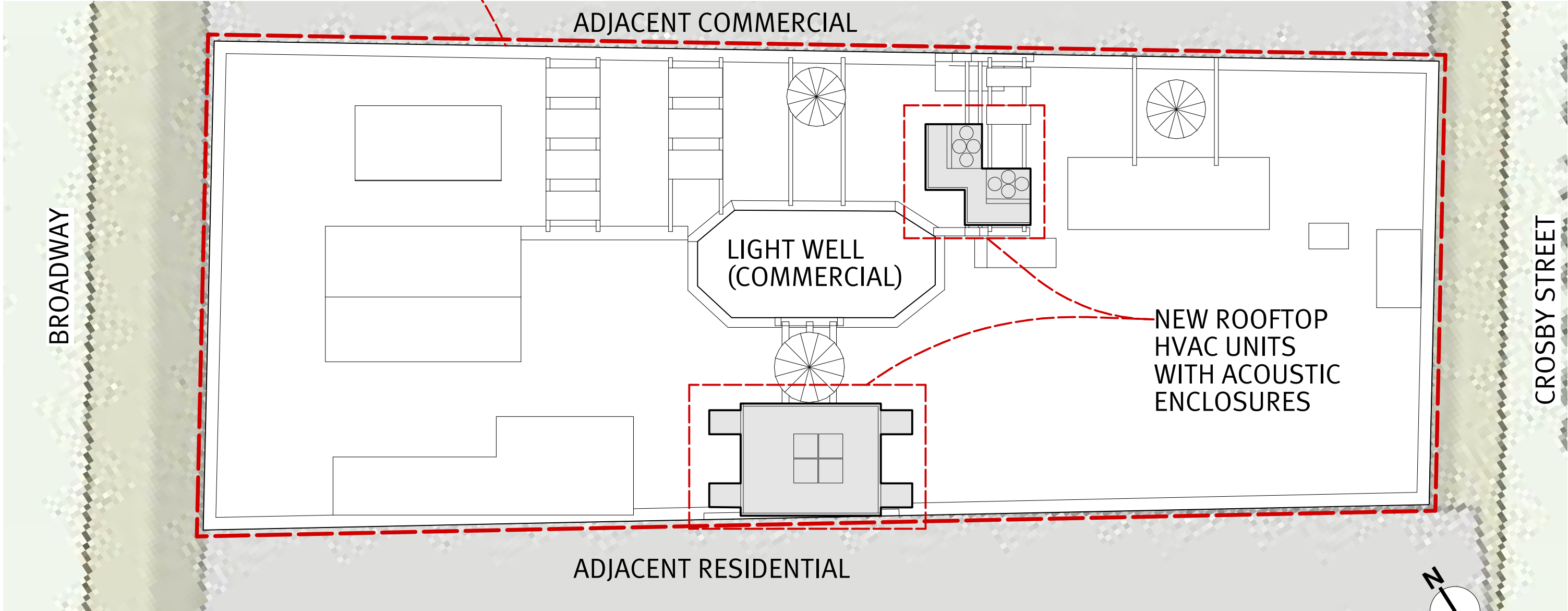

PROPOSED ROOF PLAN



# PROPOSED (ROOFTOP, NORTH)

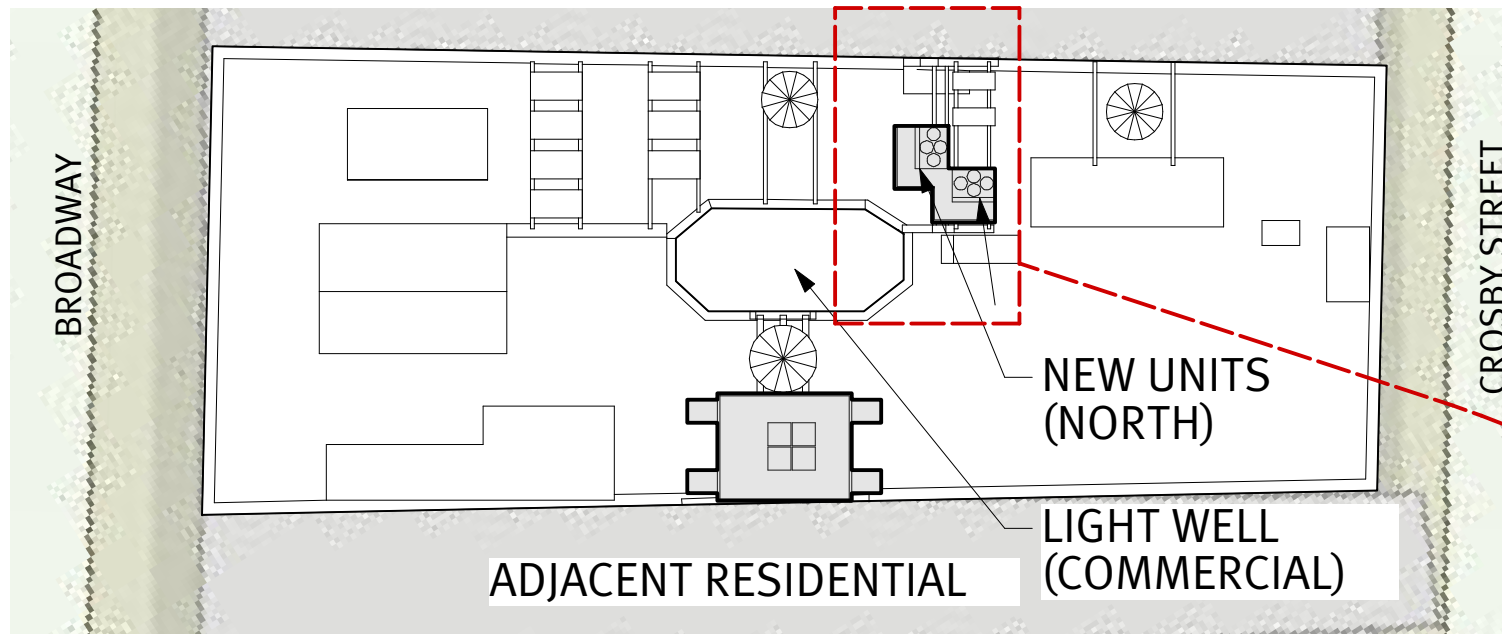

PROPOSED ROOF PLAN

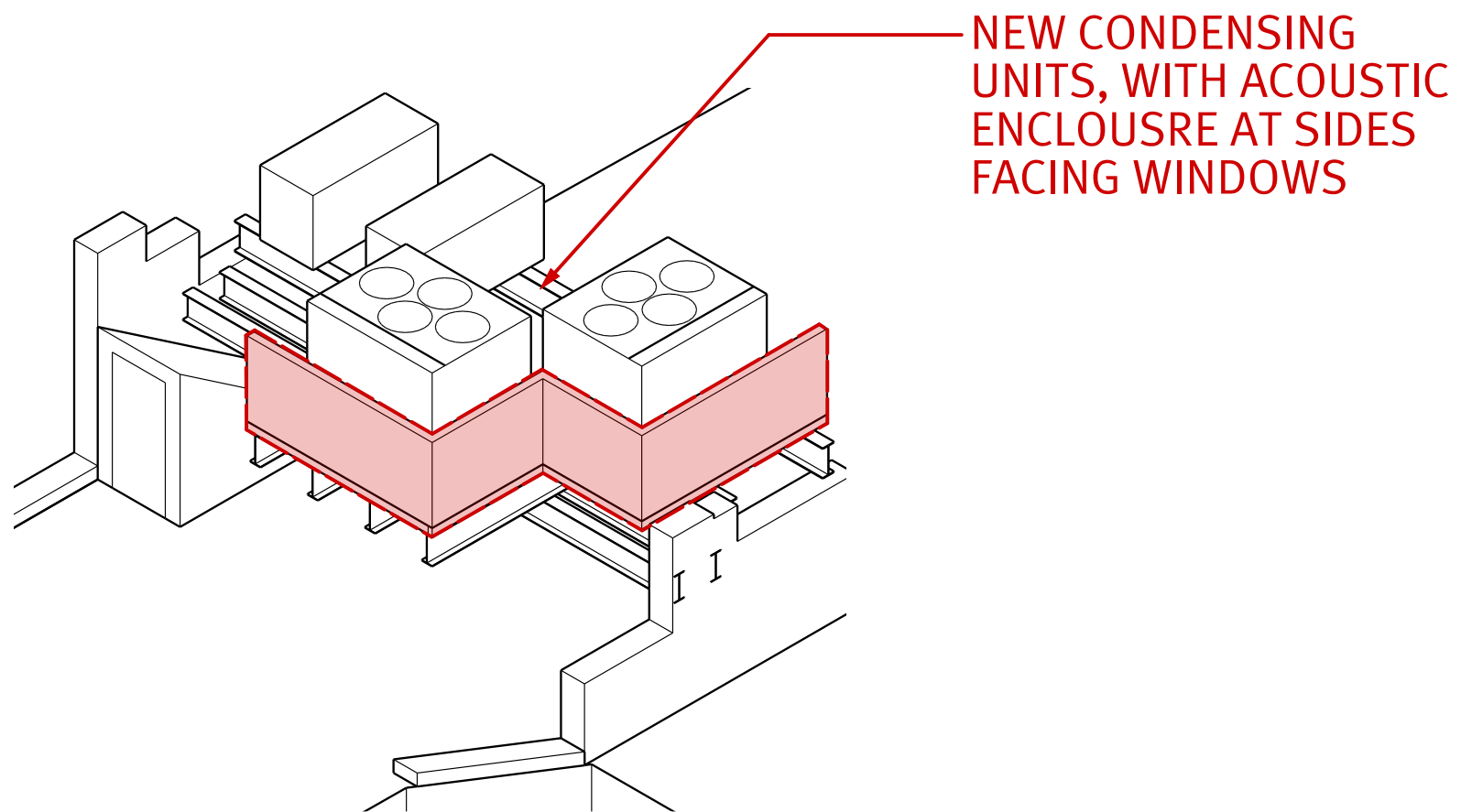

PERSPECTIVE VIEW

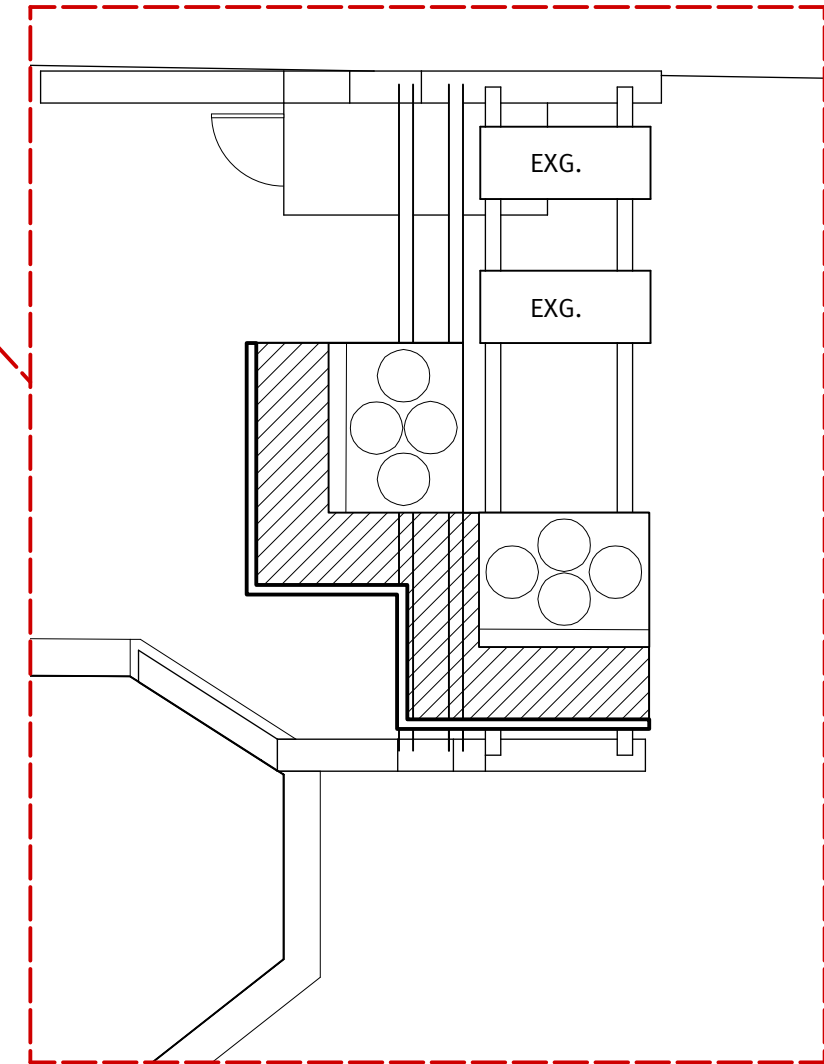

PROPOSED ROOF PLAN, DETAIL



# PROPOSED (ROOFTOP, SOUTH)

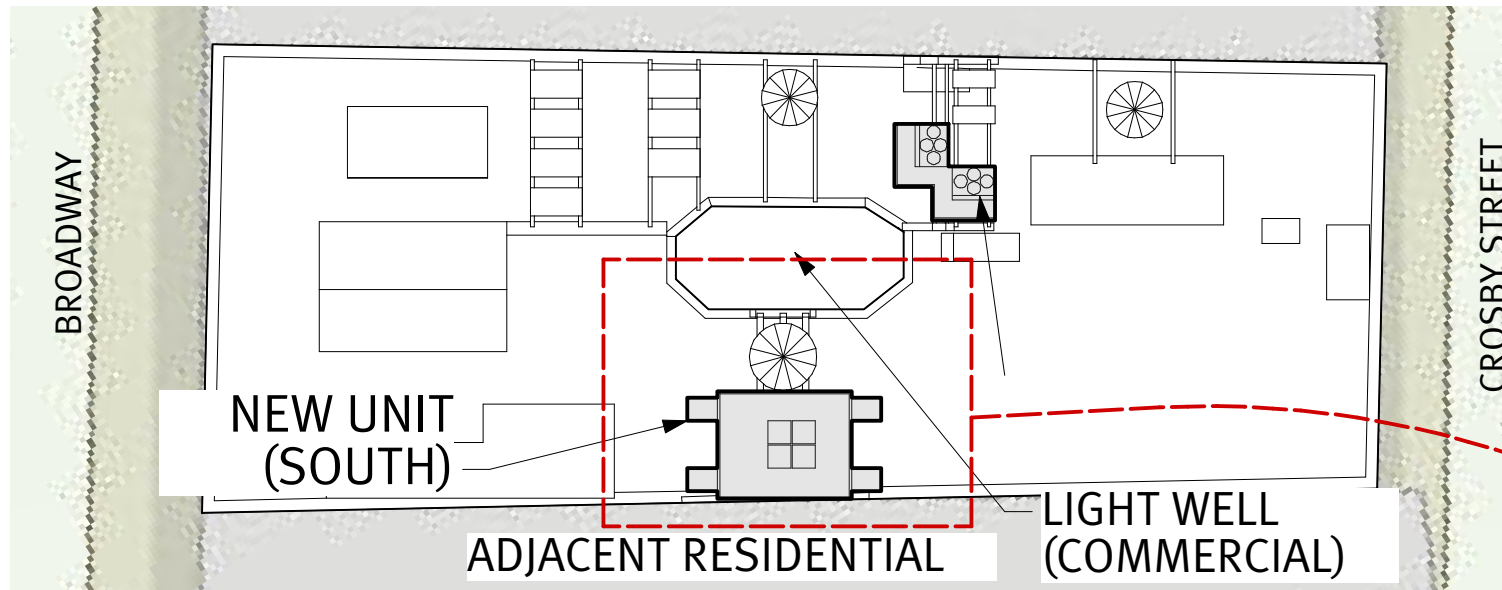

PROPOSED ROOF PLAN

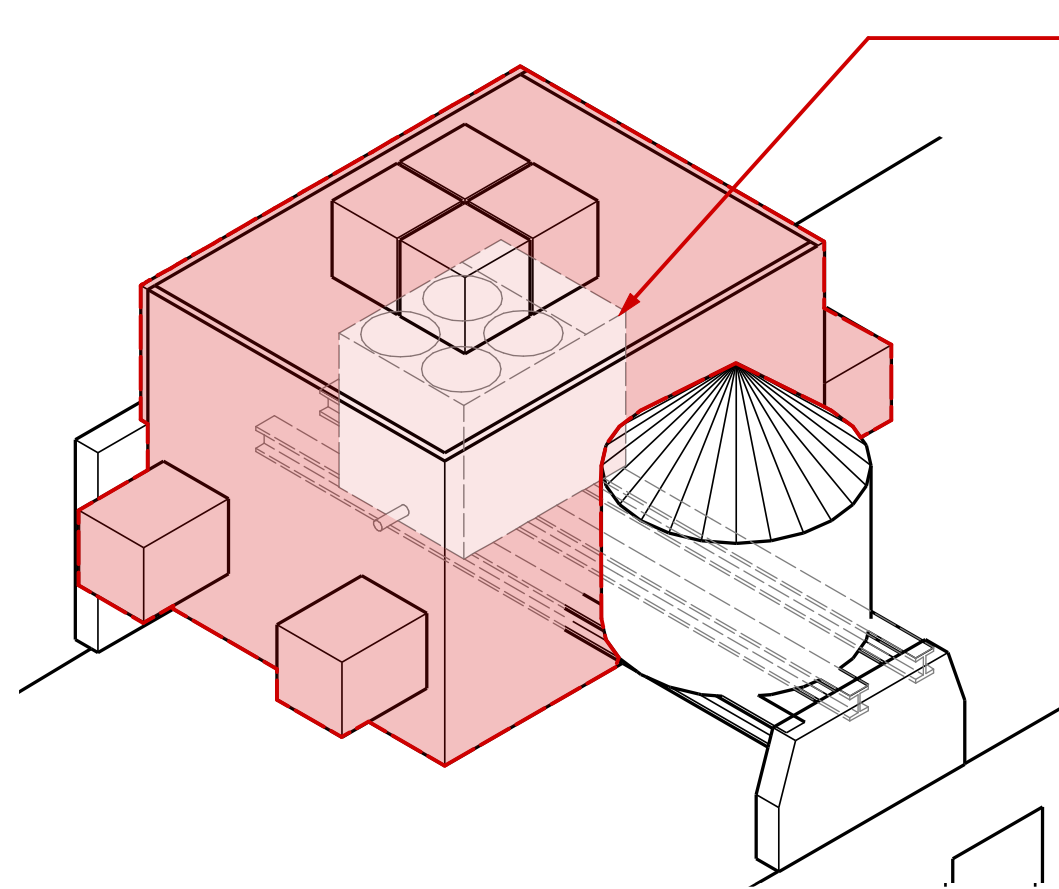

PERSPECTIVE VIEW

NEW CHILLER UNIT, WITH  
ACOUSTIC ENCLASURE  
ALL SIDES, TOP AND  
BOTTOM

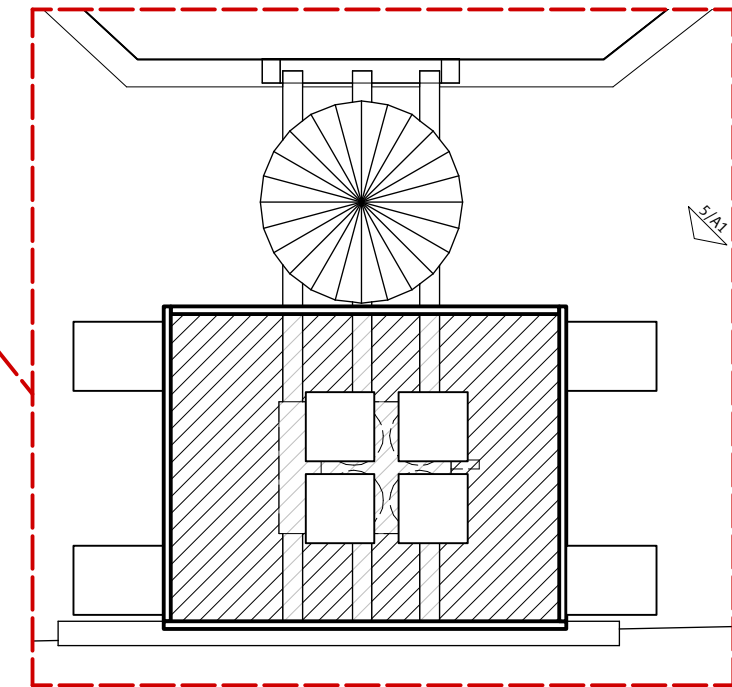

PROPOSED ROOF PLAN, DETAIL



**PROPOSED**

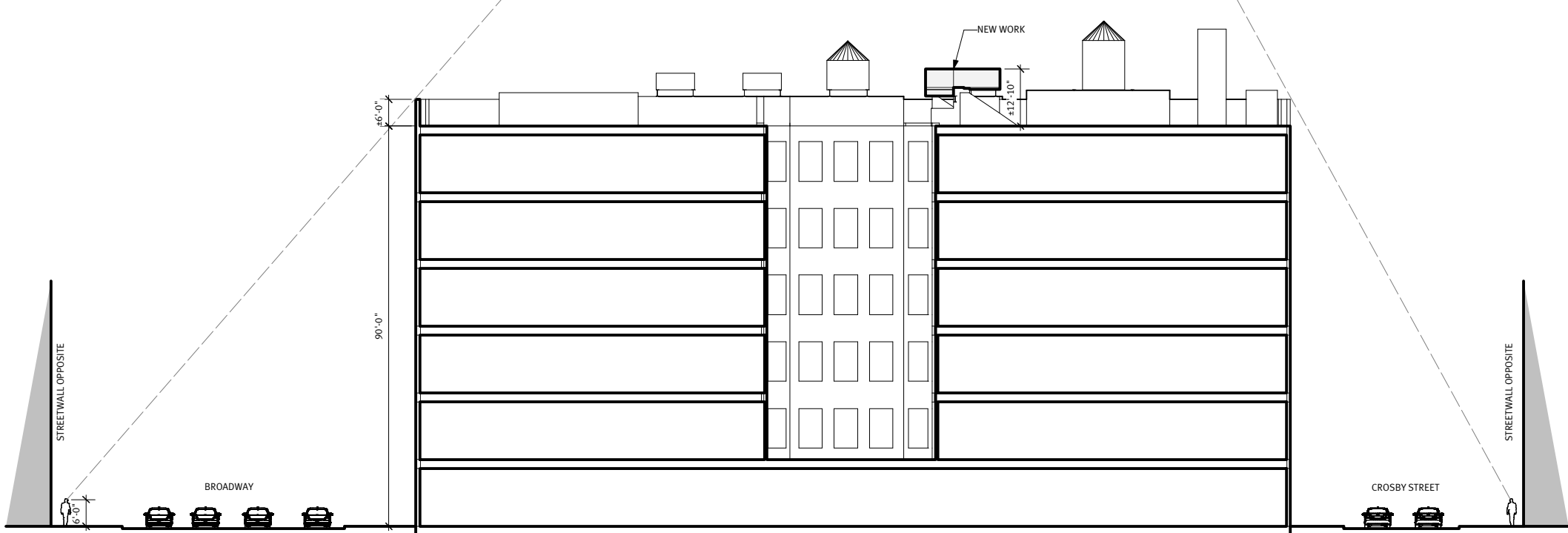

PROPOSED SECTION LOOKING NORTH

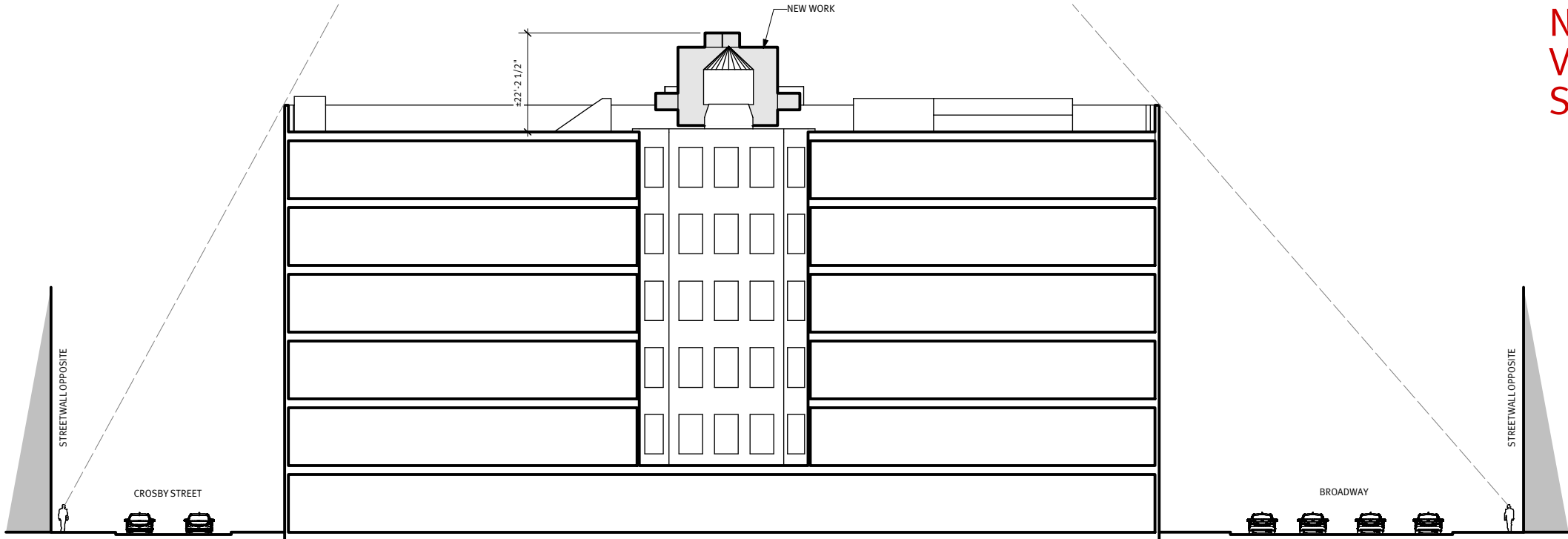

PROPOSED SECTION LOOKING SOUTH

NEW WORK IS NOT  
VISIBLE FROM ADJACENT  
STREETS



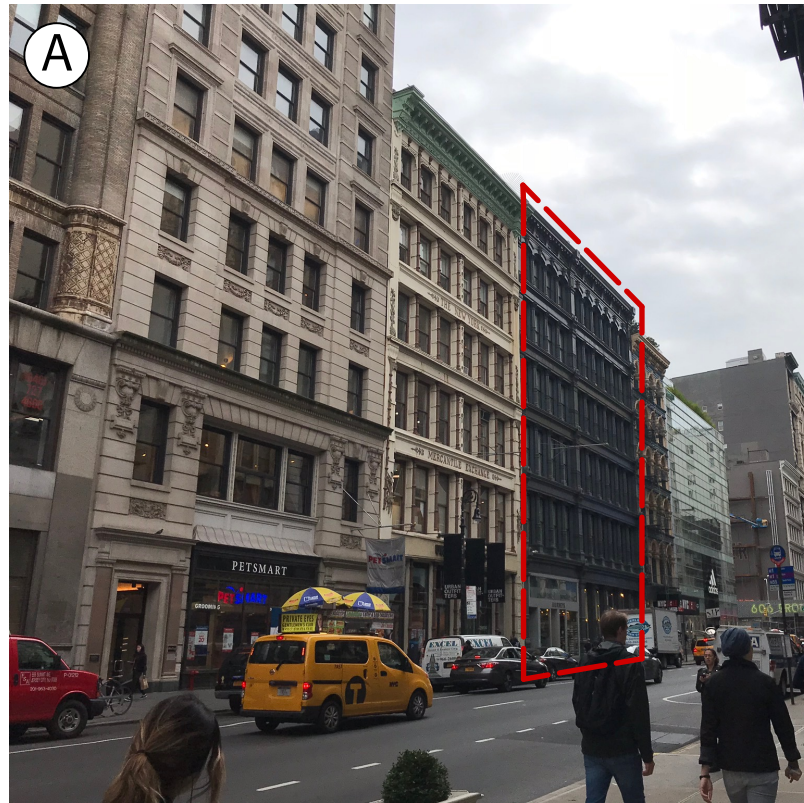

SITE PLAN

NEW WORK NOT VISIBLE FROM BROADWAY

# VIEW FROM NEIGHBORHOOD





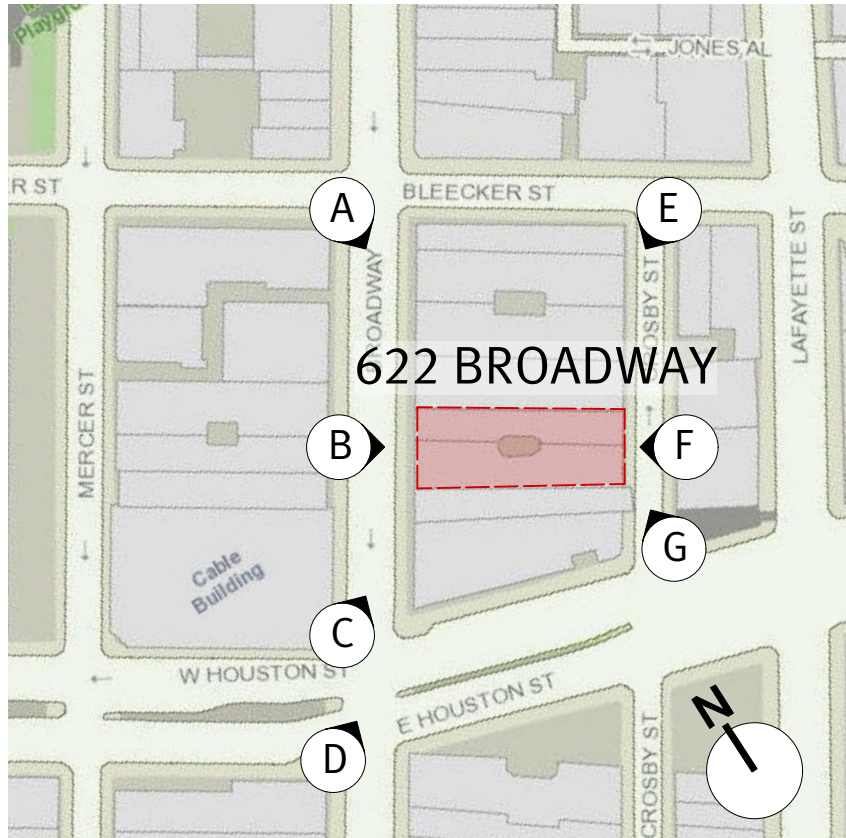

**VIEW FROM NEIGHBORHOOD**



SITE PLAN

NEW WORK NOT VISIBLE FROM CROSBY ST





# VIEW FROM NEIGHBORHOOD

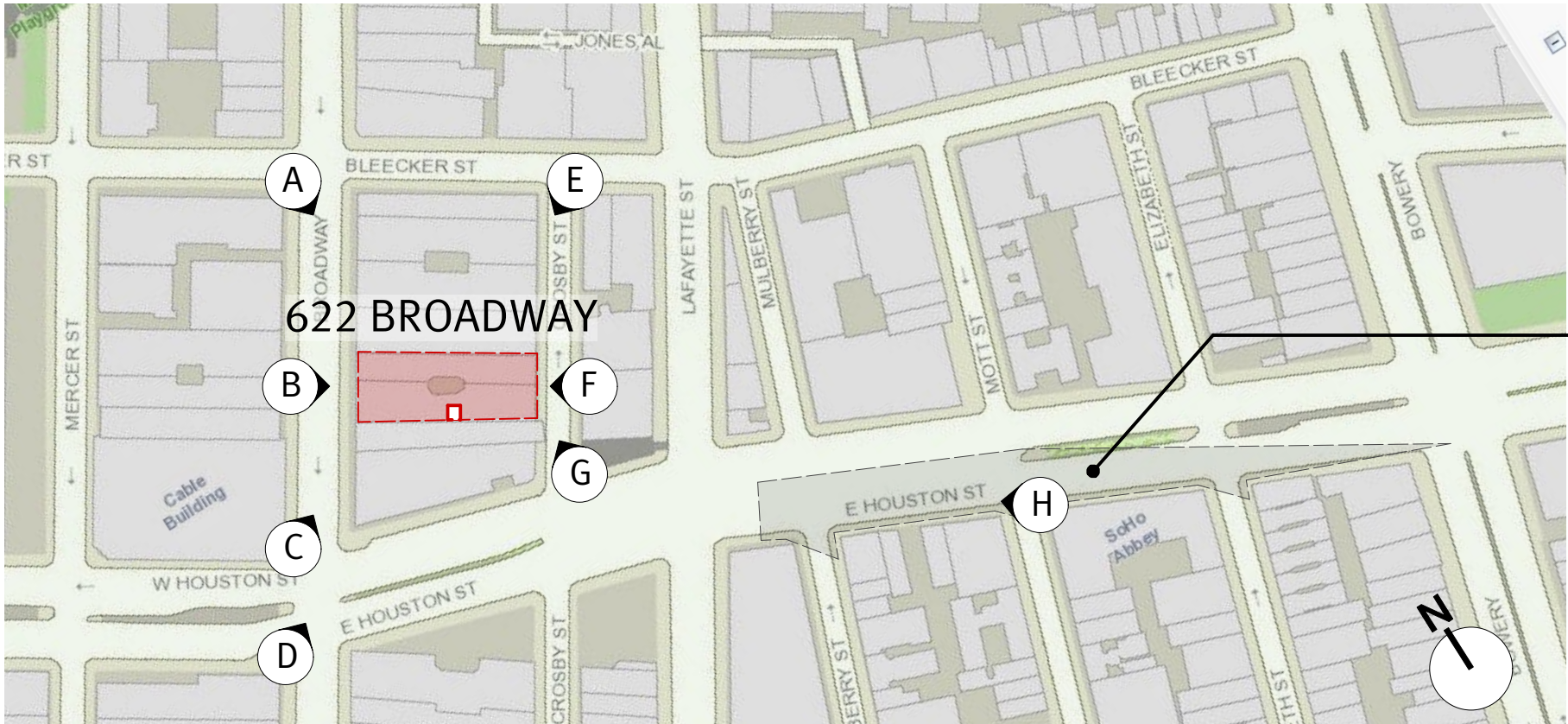

AREA OF VISIBILITY

## SITE PLAN

**SOUTH PORTION OF NEW WORK PARTIALLY VISIBLE FROM HOUSTON STREET**





**VIEW FROM NEIGHBORHOOD**



**EXISTING**

**PROPOSED**



# Best Buy NoHo

622 BROADWAY  
NEW YORK, NY 10012

ROOFTOP HVAC EQUIPMENT REPLACEMENT  
AND ACOUSTIC BARRIERS

prepared by

**BW**Architects

611 BROADWAY, SUITE 311, NEW YORK, NY 10012

