

121 WASHINGTON PLACE NEW YORK, NY 10014

BLOCK: 592 LOT: 78 MAP:12A ZONING DISTRICT: R6
COMMUNITY BOARD: 102 ;LANDMARK
GREENWICH VILLAGE HISTORIC DISTRICT
LOT FRONTAGE: 22' LOT DEPTH:97' LOT AREA: 2134 SF
NUMBER OF FLOORS: 4
OCCUPANCY CLASSIFICATION: RESIDENTIAL
CONSTRUCTION CLASSIFICATION: NON-FIREPROOF

LIST OF SLIDES

- 00 TITLE PAGE
- 01 SITE LOCATION AND CONTEXT
- 02 ENLARGED BLOCK PLAN: INTERIOR VOID SPACES
- 03 TIMELINE OF CONSTRUCTION
- 04 EXISTING FACADE IMAGES
- 05 EXISTING ALLEY IMAGES
- 06 EXISTING PLANS: CELLAR, FIRST AND SECOND
- 07 EXISTING PLANS: THIRD, FOURTH AND ROOF
- 08 PROPOSED PLANS: CELLAR, FIRST AND SECOND
- 09 PROPOSED PLANS: THIRD, FOURTH AND ROOF
- 10 EXISTING ELEVATIONS
- 11 PROPOSED ELEVATIONS
- 12 EXISTING AND PROPOSED CARRIAGE HOUSE NORTH ELEVATIONS
- 13 EXISTING EAST FACADE
- 14 PROPOSED EAST FACADE
- 15 EXISTING SECTION
- 16 PROPOSED SECTION
- 17 LPC SLIGHTLINE DIAGRAM

NOTE:

COMMISSIONER AND COMMUNITY BOARD SHOULD NOTE THAT ALL PROPOSED WORK OUTSIDE OF EXCAVATION, FOURTH FLOOR NORTH FACING WINDOW AND CARRIAGE HOUSE FACADE WORK TO BE REVIEWED AT STAFF LEVEL AT THE LANDMARKS PRESERVATION COMMISSION.



121 WASHINGTON PLACE, 1940 TAX MAP



GREENWICH VILLAGE SITE CONTEXT MAP
N.T.S



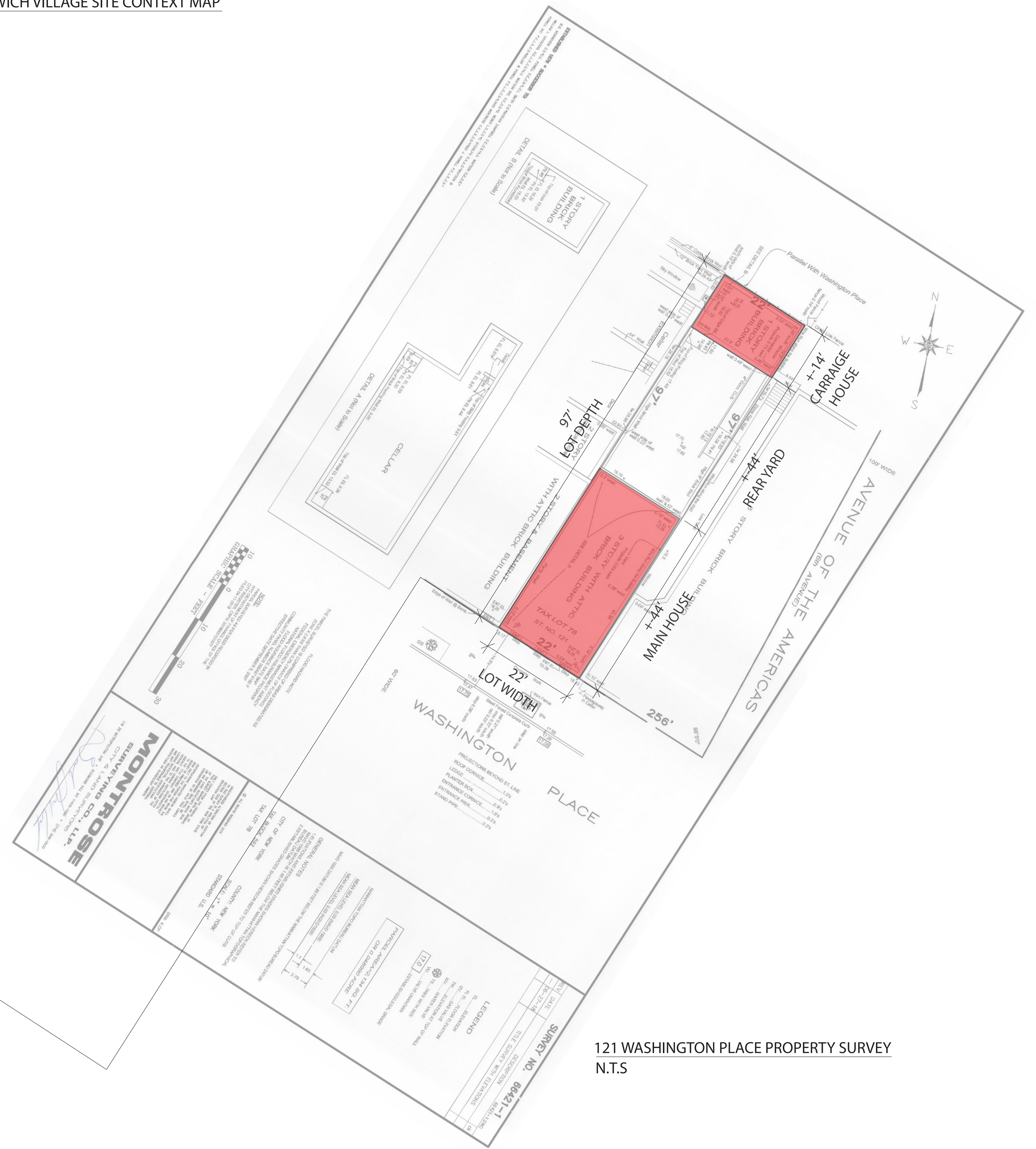

GREENWICH VILLAGE PARTIAL TAX MAP
N.T.S

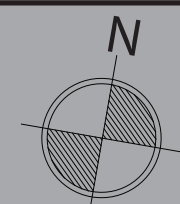

121 WASHINGTON PLACE PROPERTY SURVEY
N.T.S

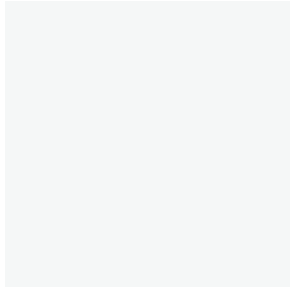
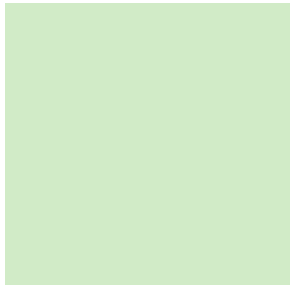

LEGEND

-  BUILDING
-  OPEN SPACE IN INTERIOR OF BLOCK
-  121 WASHINGTON PLACE: PROJECT LOCATION



GREENWICH VILLAGE PARTIAL TAX MAP
SEE SCALE BELOW





123 AND 121 WASHINGTON PLACE
1920



121 WASHINGTON PLACE
1923



121 WASHINGTON PLACE
1940



121 WASHINGTON PLACE
2018



1833

1835
121-127 WASHINGTON PLACE
BUILT BY DEVELOPERS JOHN
NICHOLS & WILLIAM CARROLL

1907
CLARA DAVIDGE PUR-
CHASES 121 WASHGIN-
TON PLACE

CLARA DAVIDGE EMPYS ARCHITECTS
HENRY KILLIAM MURPHY AND RICHARD
HENRY DANS JR TO DESIGN STUDIO FOR
POET EDWIN ARLINGTON ROBINSON,
WHO LIVES IN STUDIO FOR TWO YEARS

2 BLOCK ROAD BE-
TWEEN WASHINGTON
SQUARE PARK WEST
AND WEST 4TH NAMED
WASHGINTON PLACE

1909
1 STORY EXTENSION BUILT,
BELIEVED TO BE AT REAR OF HOUSE

1912
1919

HOME SOLD TO OLIVER HARRISON
SMITH, EVENTUALLY REMODELED FROM
A SINGLE FAMILY HOME TO MULTIPLE
STUDIO APARTMENTS. BELIEVED TO BE
EXCLUSIVELY INTERIOR WORK.

1925
HOUSE REMODELED INTO CURRENT
ITERATION AND BACK INTO A SINGLE
FAMILY HOME. THE FLOOR LEVELS
ALTERED WITH THE ENTRY LEVEL
LANDING AT SIDEWALK LEVEL. A NEW
FOURTH FLOOR ADDED, AND A NEW
FACADE BUILT WITH A GEORGIAN
AESTHETIC.

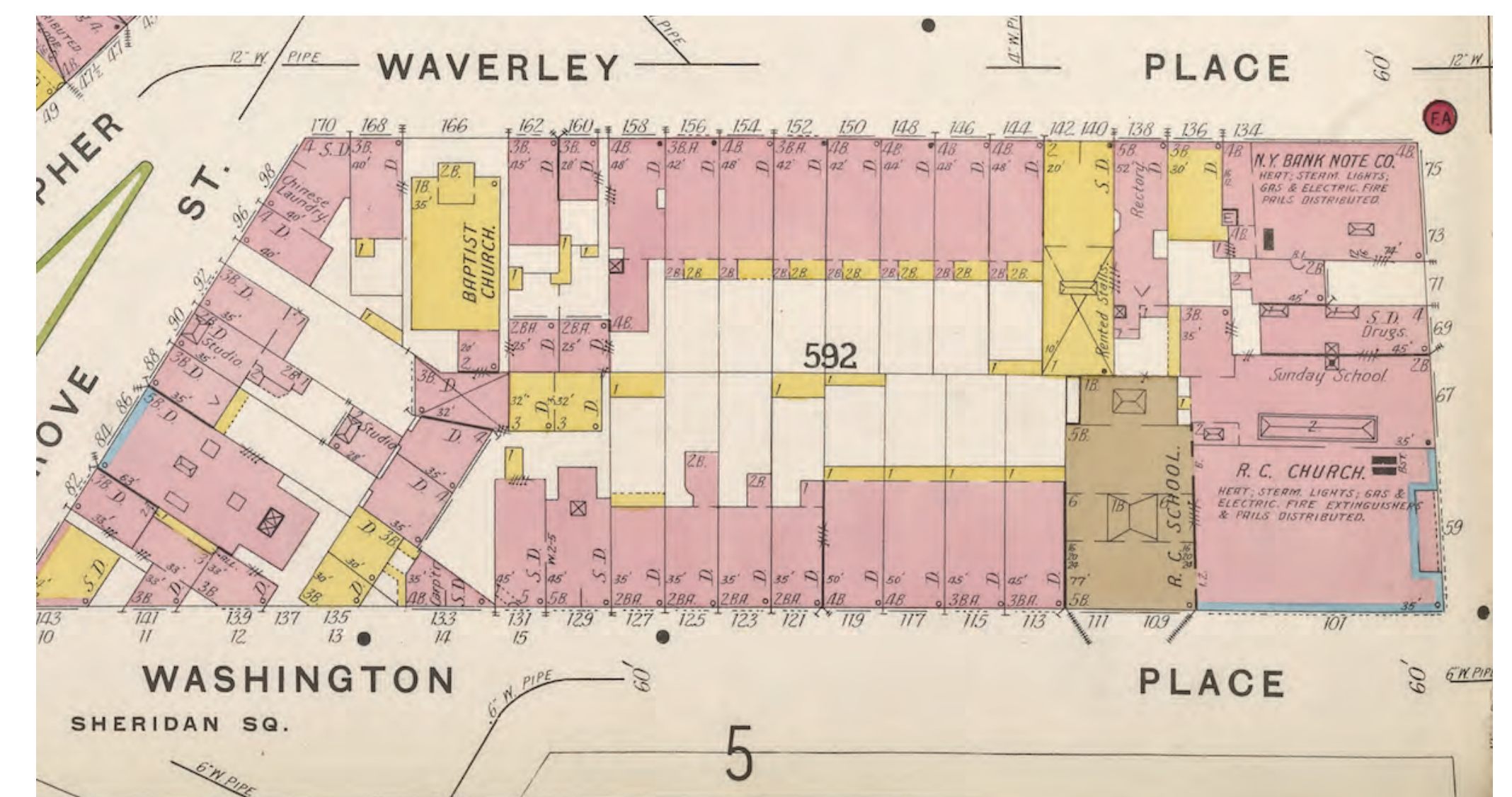

SECTION OF SANBORN MAP
1904



01 VIEW OF EXISTING FRONT FACADE



02 VIEW OF EXISTING FRONT DOOR



03 VIEW OF REAR FACADE



04 VIEWS OF EXISTING ARTIST STUDIOS FACADE



01 VIEW OF ALLEY LOOKING SOUTH



02 VIEW OF ALLEY LOOKING NORTH



03 VIEW OF EAST FACADE OF 121 LOOKING NORTH



04 VIEW OF EAST FACADE OF STUDIO LOOKING NORTH

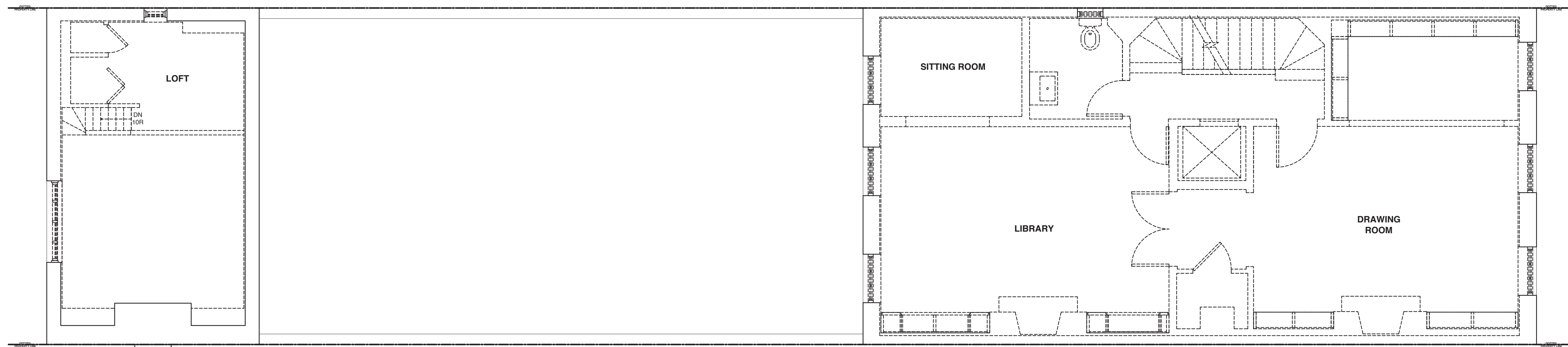

SECOND FLOOR

LEGEND

— EXISTING TO REMAIN

- - - EXISTING TO BE REMOVED

02 REMOVALS PLAN - EXISTING SECOND FLOOR
SEE SCALE BELOW

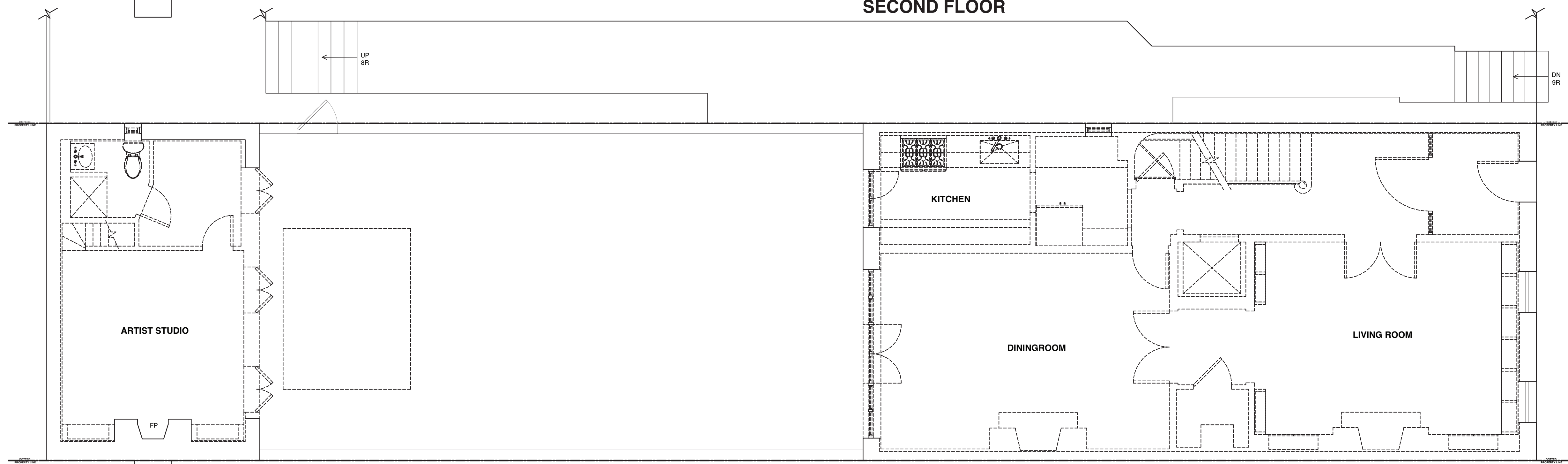

01 REMOVALS PLAN - EXISTING FIRST FLOOR
SEE SCALE BELOW

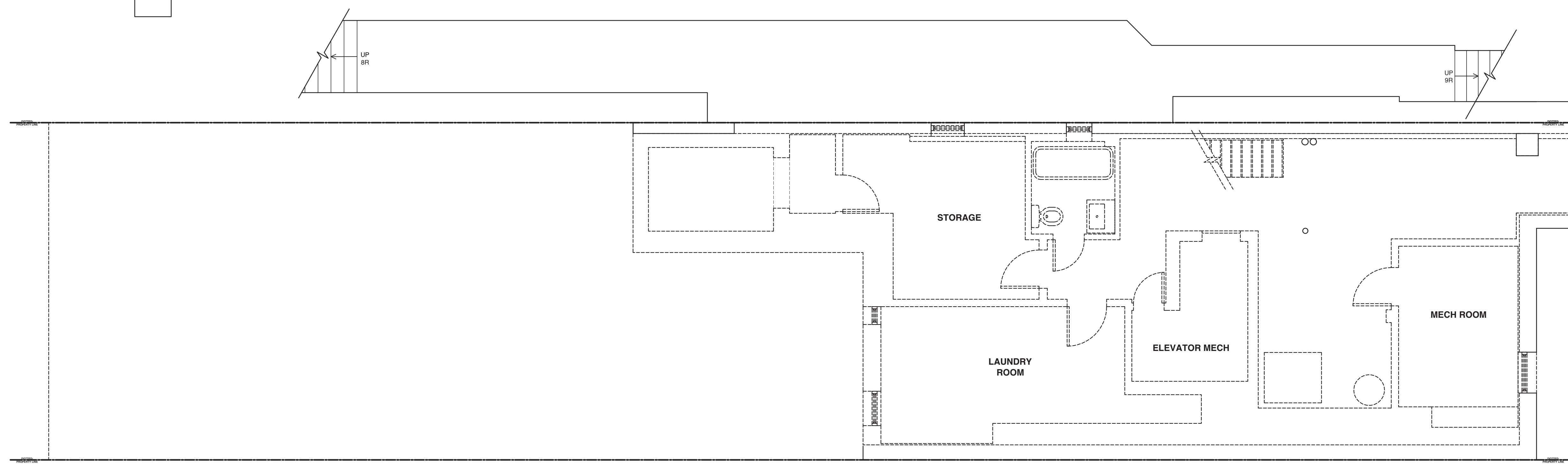

00 REMOVALS PLAN - EXISTING CELLAR
SEE SCALE BELOW

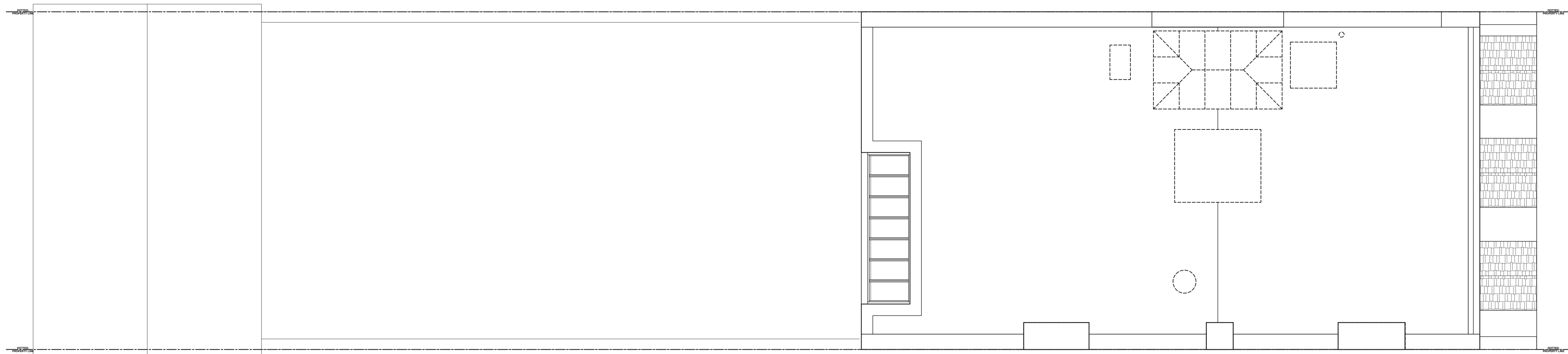

LEGEND

——— EXISTING TO REMAIN

- - - - EXISTING TO BE REMOVED

05 REMOVALS PLAN - EXISTING ROOF
SEE SCALE BELOW

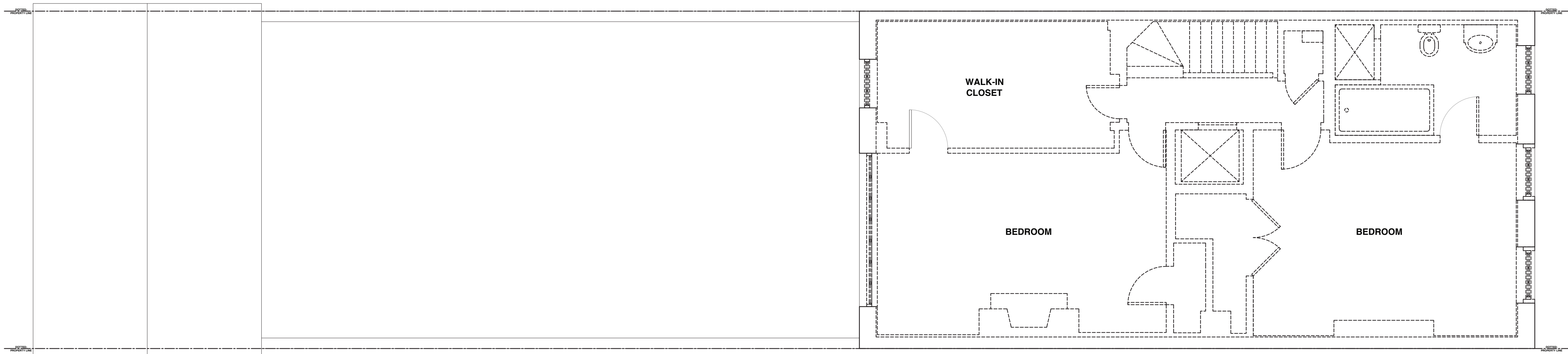

04 REMOVALS PLAN - EXISTING FOURTH FLOOR
SEE SCALE BELOW

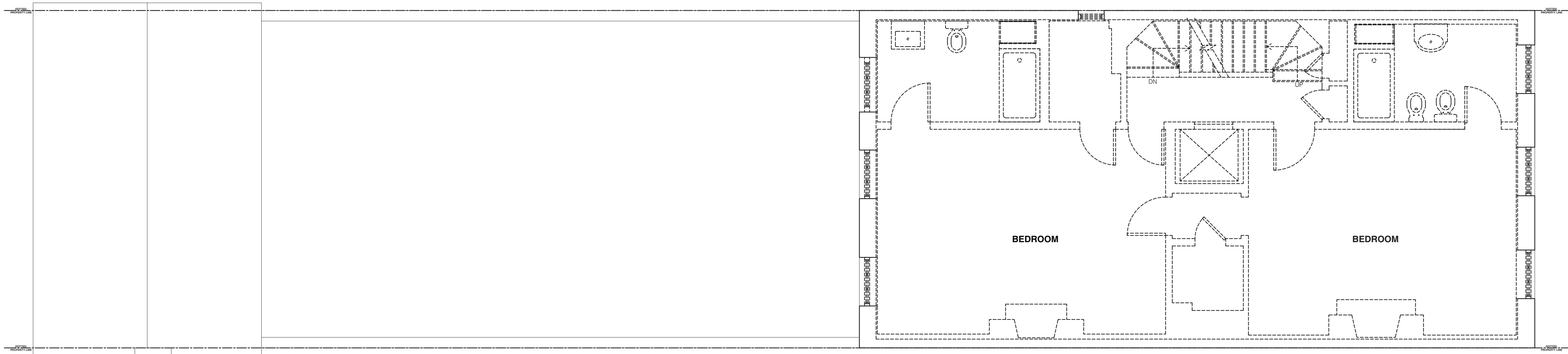

03 REMOVALS PLAN - EXISTING THRID FLOOR
SEE SCALE BELOW

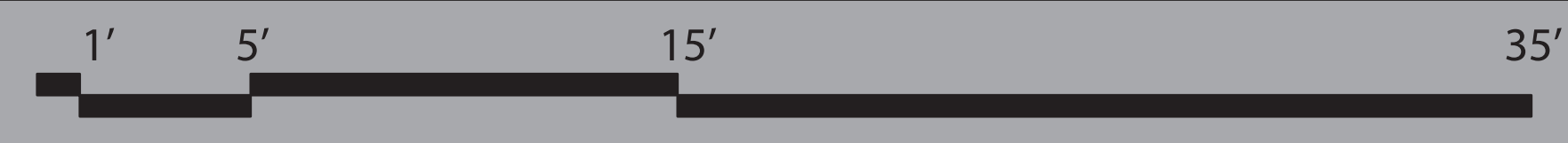

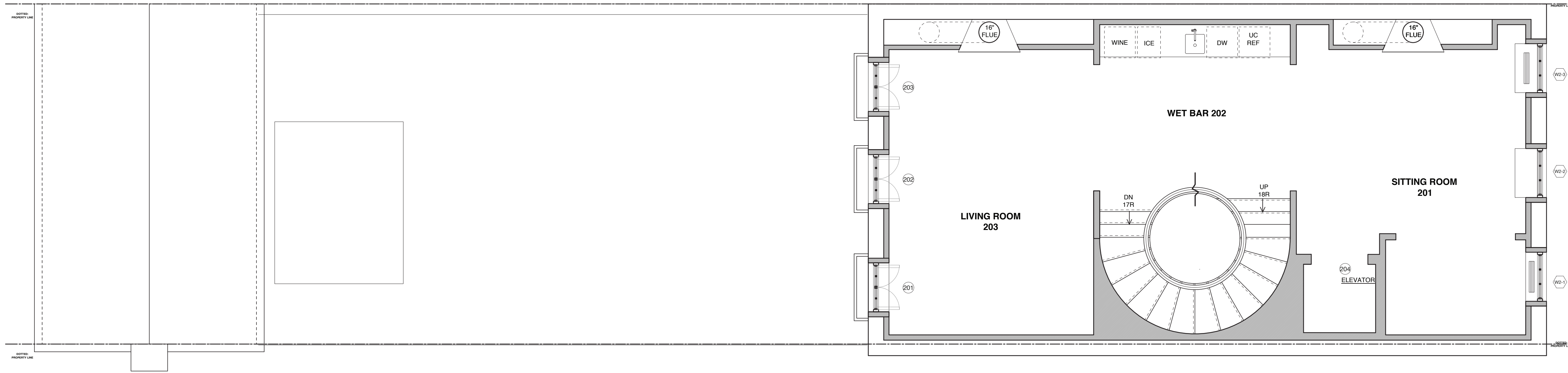

LEGEND

- EXISTING TO REMAIN
- NEW CONSTRUCTION

02 PROPOSED PLAN - SECOND FLOOR
SEE SCALE BELOW

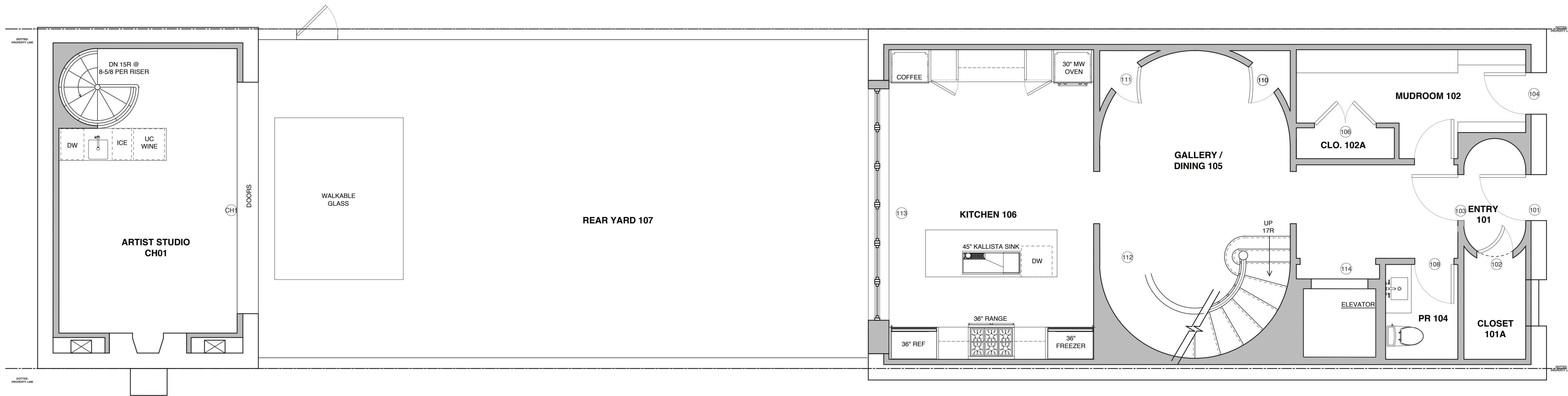

01 PROPOSED PLAN - FIRST FLOOR
SEE SCALE BELOW

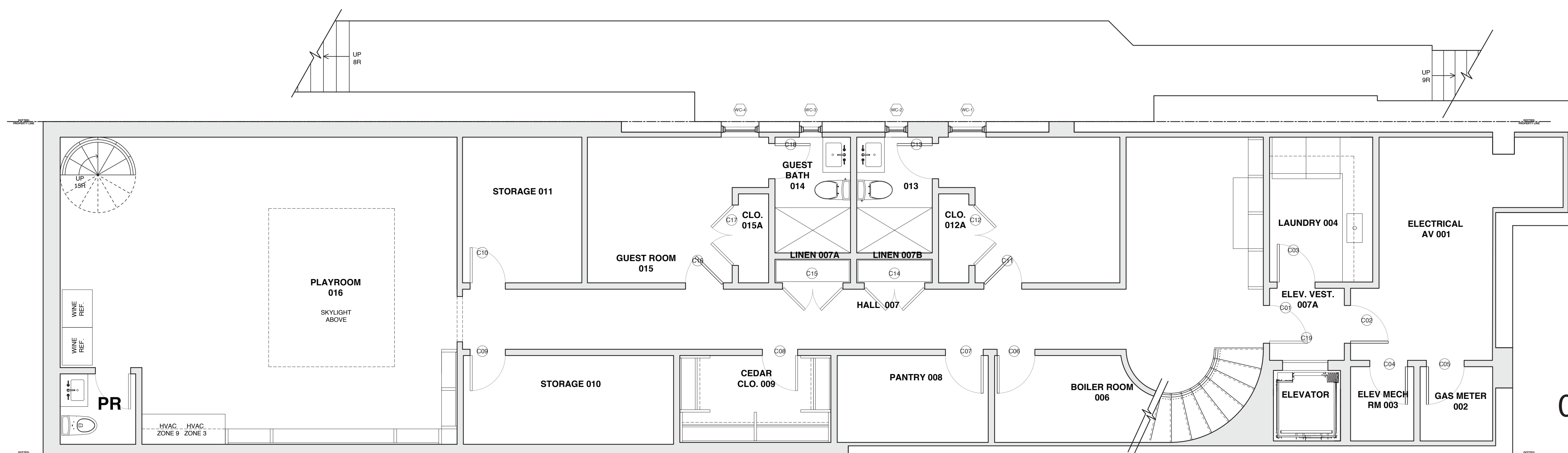

00 PROPOSED PLAN - CELLAR
SEE SCALE BELOW



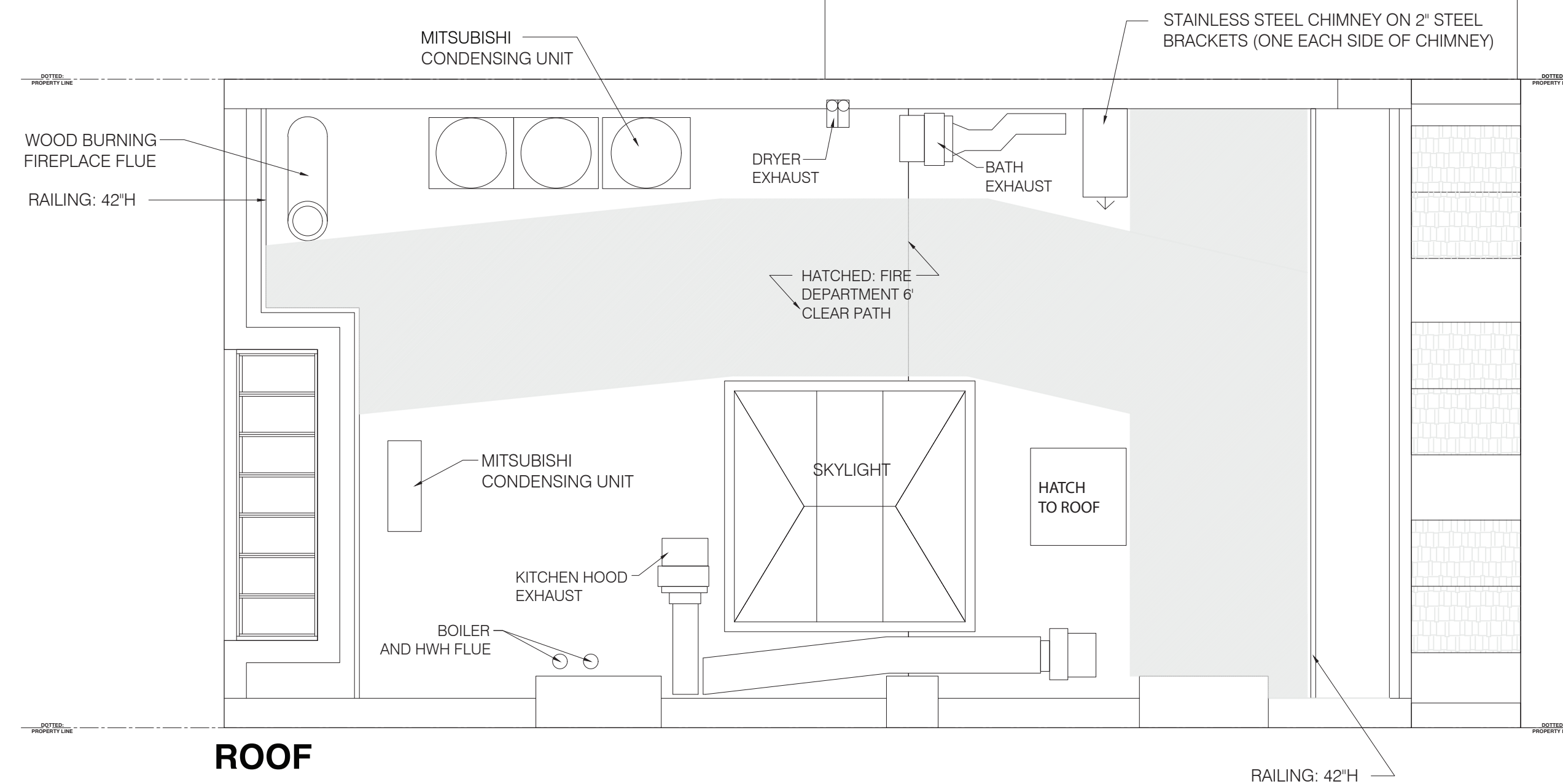

LEGEND

-  EXISTING TO REMAIN
-  NEW CONSTRUCTION

05 PROPOSED PLAN: ROOF
SEE SCALE BELOW

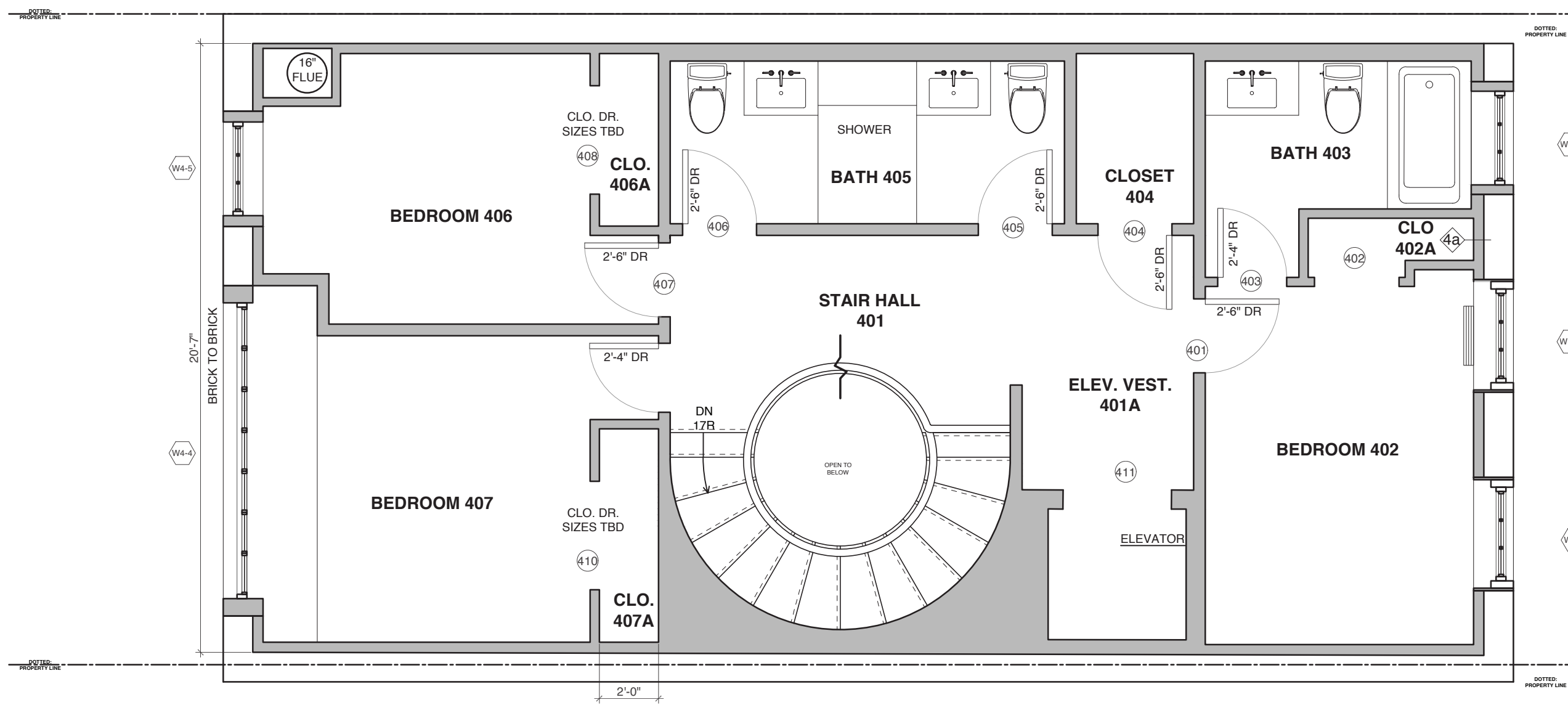

04 PROPOSED PLAN - FOURTH FLOOR
SEE SCALE BELOW

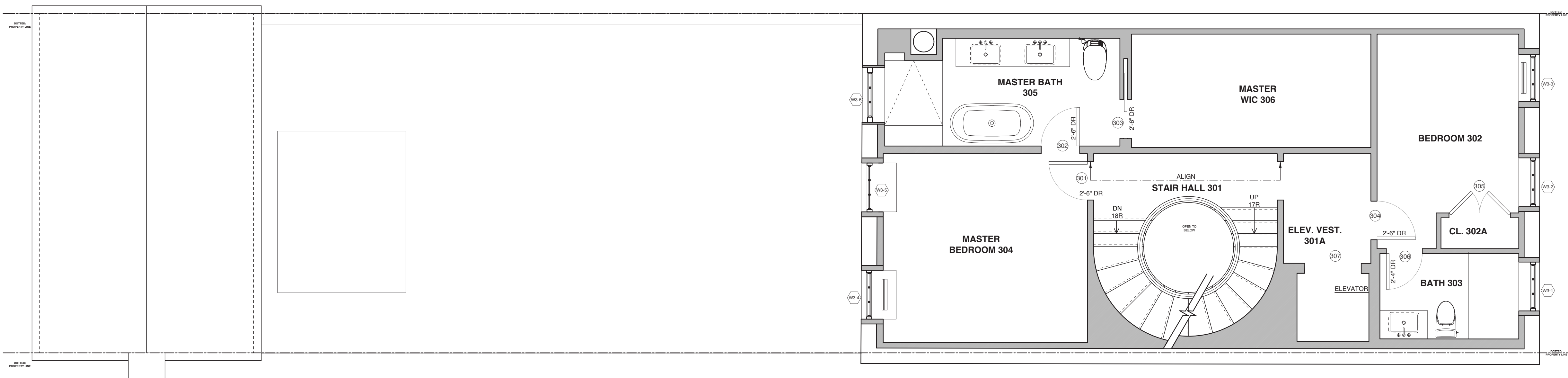

03 PROPOSED PLAN: THIRD FLOOR
SEE SCALE BELOW





01 MAIN HOUSE- SOUTH FACING ELEVATION (FRONT FACADE)
SEE SCALE BELOW

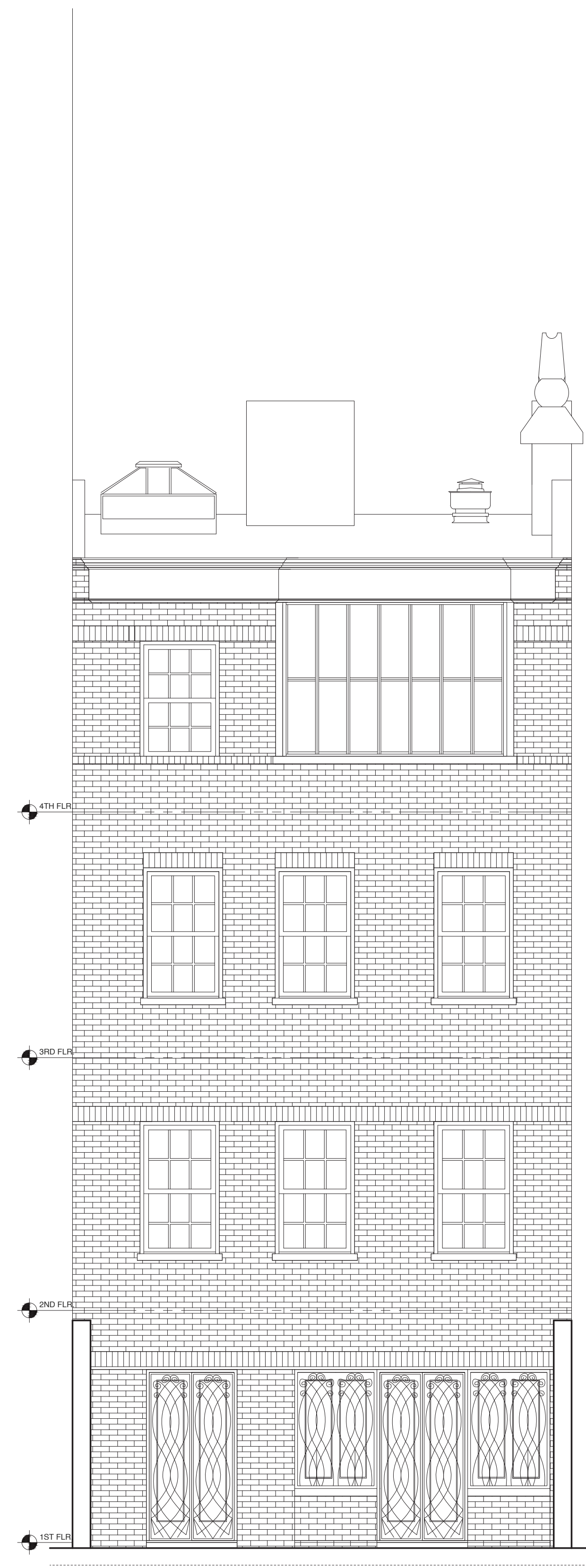

02 MAIN HOUSE- NORTH FACING ELEVATION (REAR FACADE)
SEE SCALE BELOW

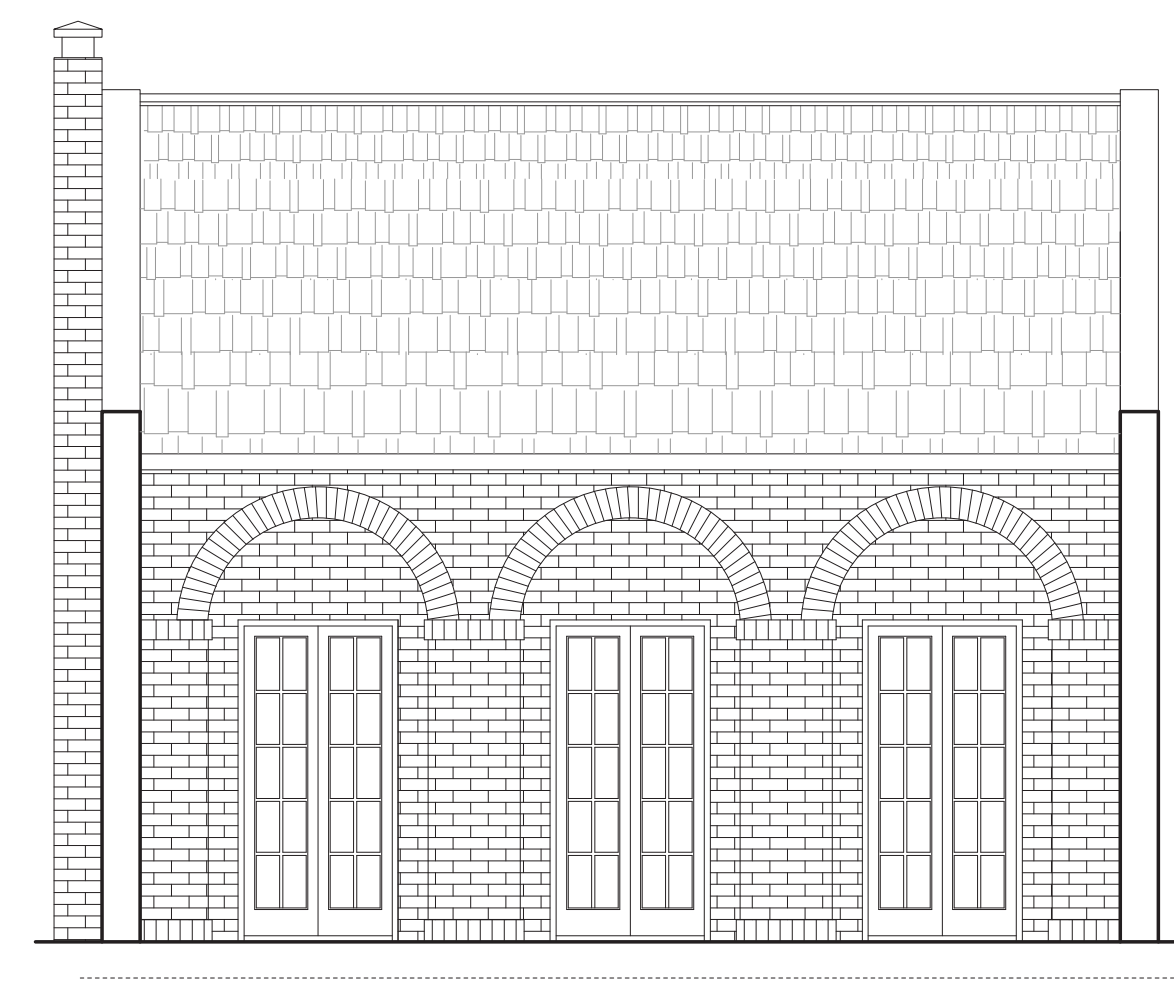

03 MAIN HOUSE- NORTH FACING ELEVATION (REAR FACADE)
SEE SCALE BELOW

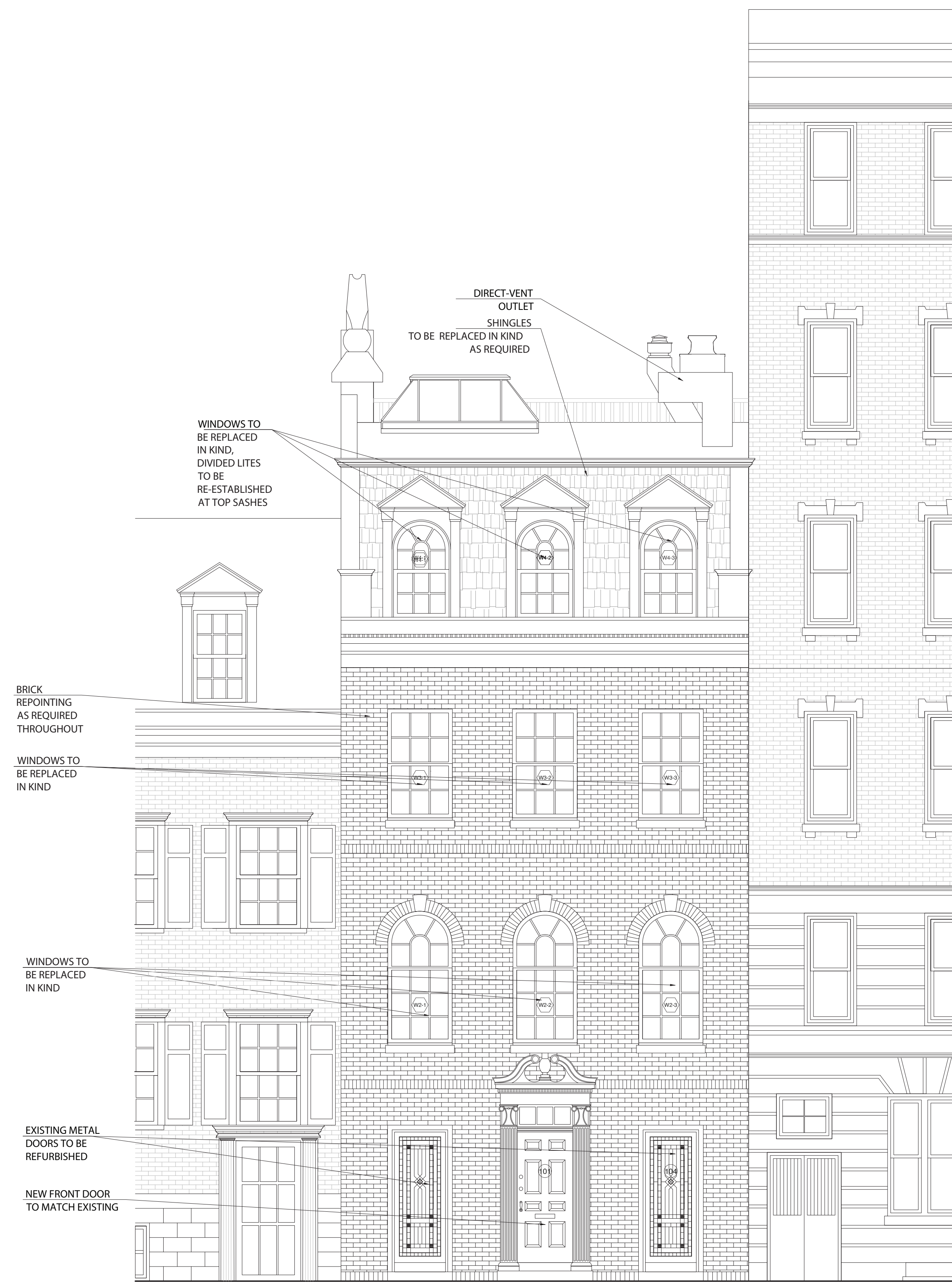

01 MAIN HOUSE- SOUTH FACING ELEVATION (FRONT FACADE)
SEE SCALE BELOW

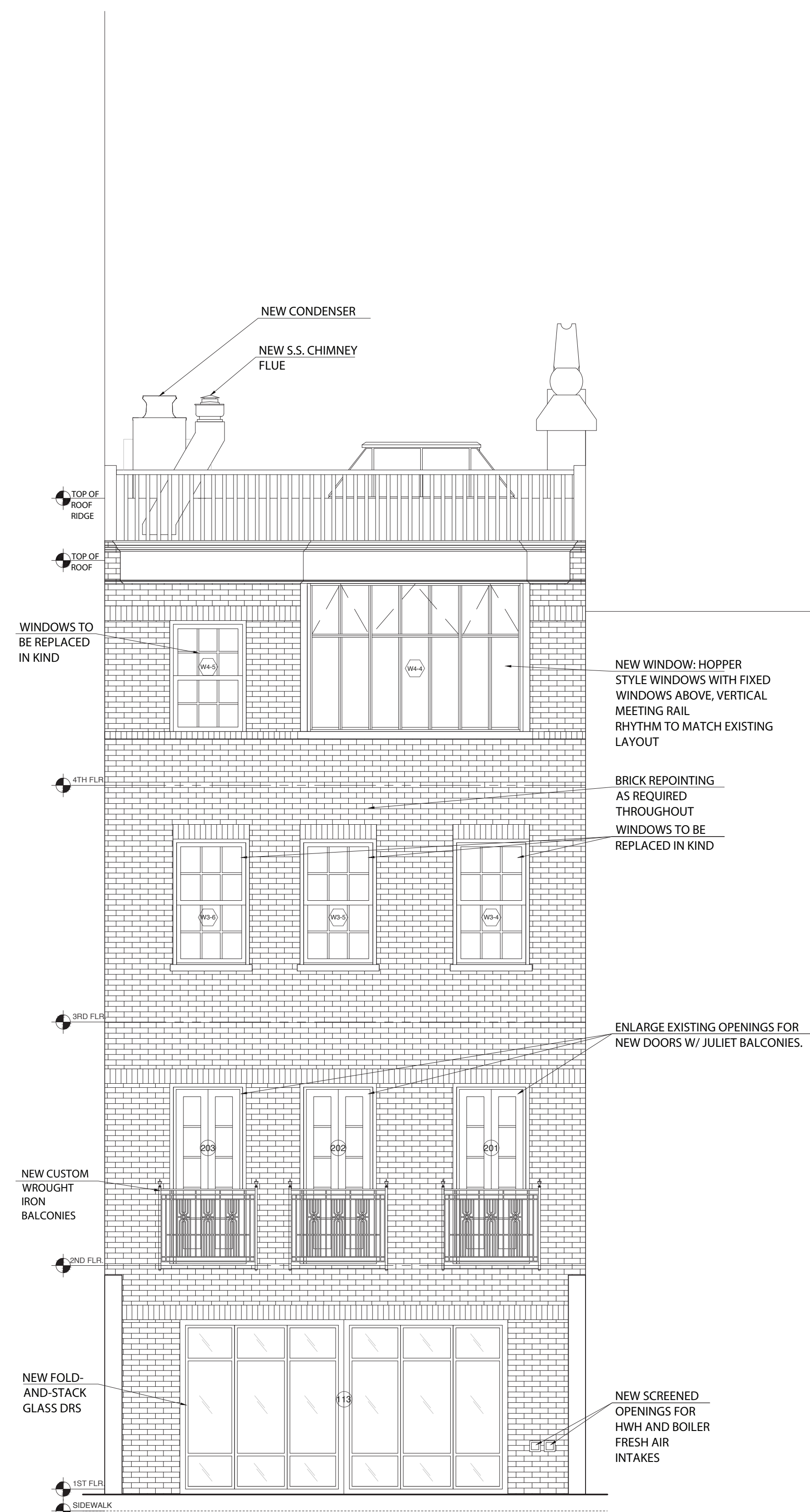

02 MAIN HOUSE- NORTH FACING ELEVATION (REAR FACADE)
SEE SCALE BELOW

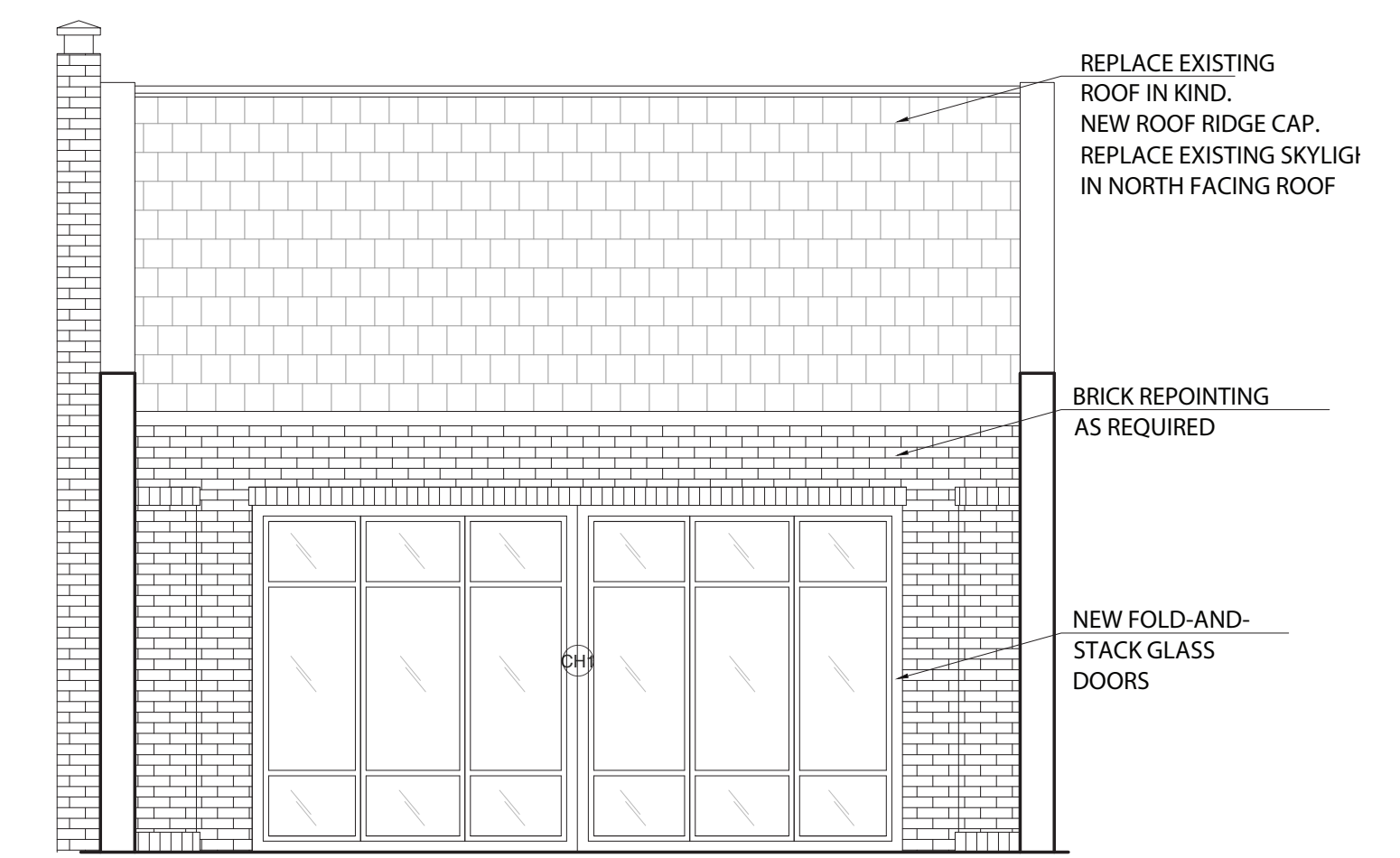

03 MAIN HOUSE- NORTH FACING ELEVATION (REAR FACADE)
SEE SCALE BELOW



VIEW OF EXISTING SKYLIGHT OPENING BEFORE INTERIOR DEMOLITION



VIEW OF EXISTING SKYLIGHT OPENING AFTER INTERIOR DEMOLITION, REVEALING ORIGINAL SIZE

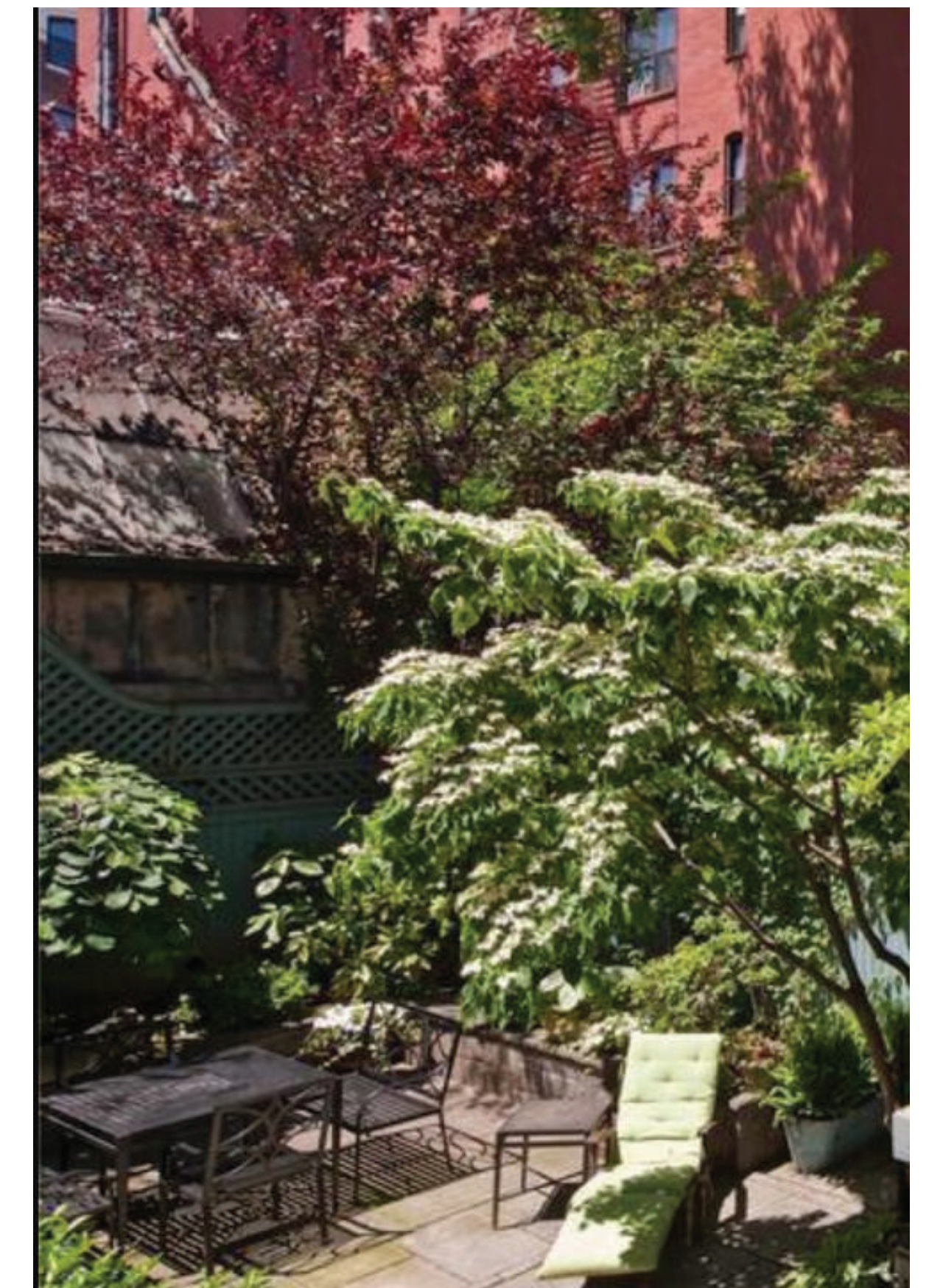

VIEW OF EXISTING SKYLIGHT FROM LAWN OF NEIGHBOR TO THE NORTH

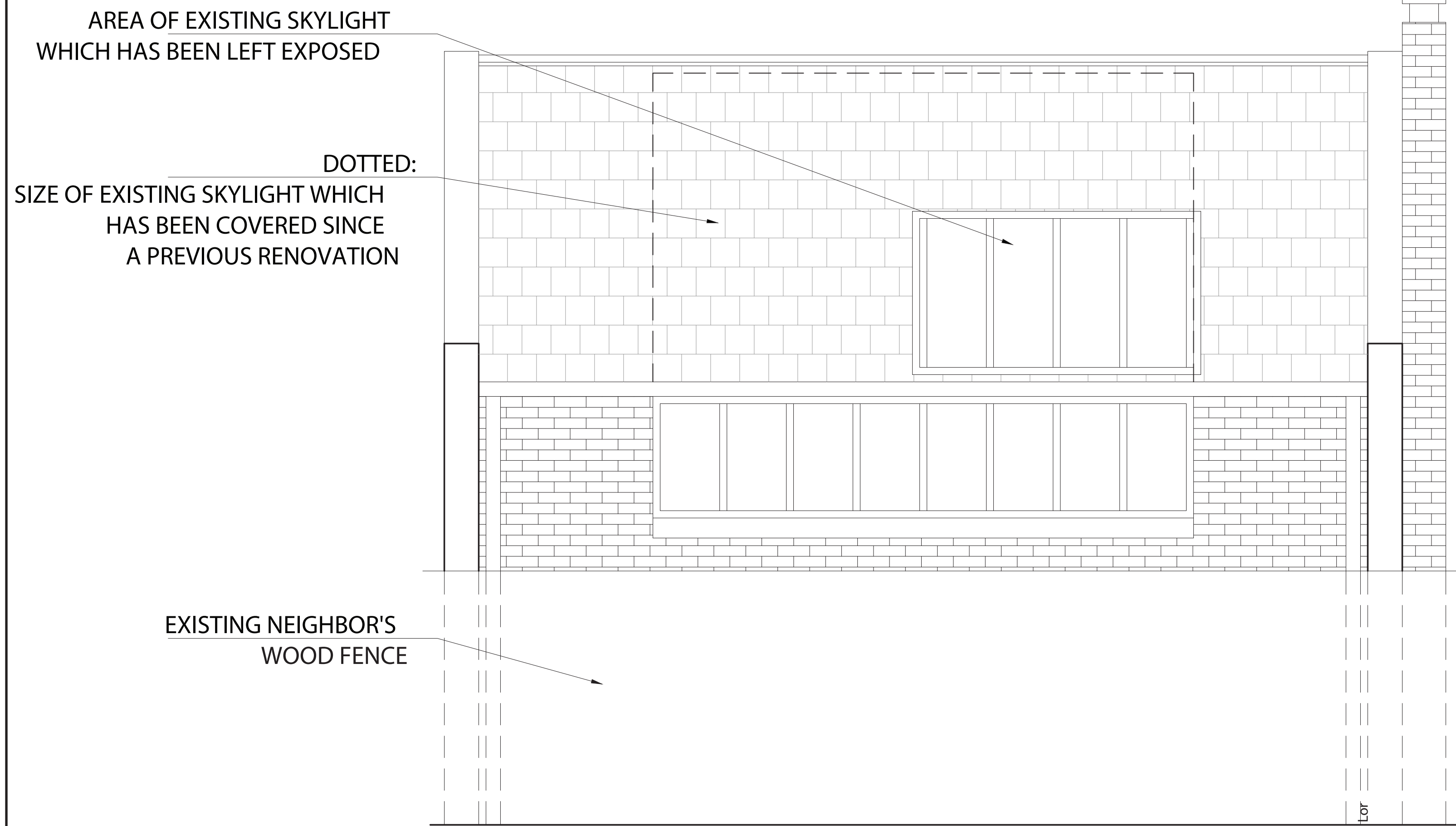

01 CARRIAGE HOUSE- EXISTING NORTH FACING ELEVATION (REAR FACADE)
SEE SCALE BELOW

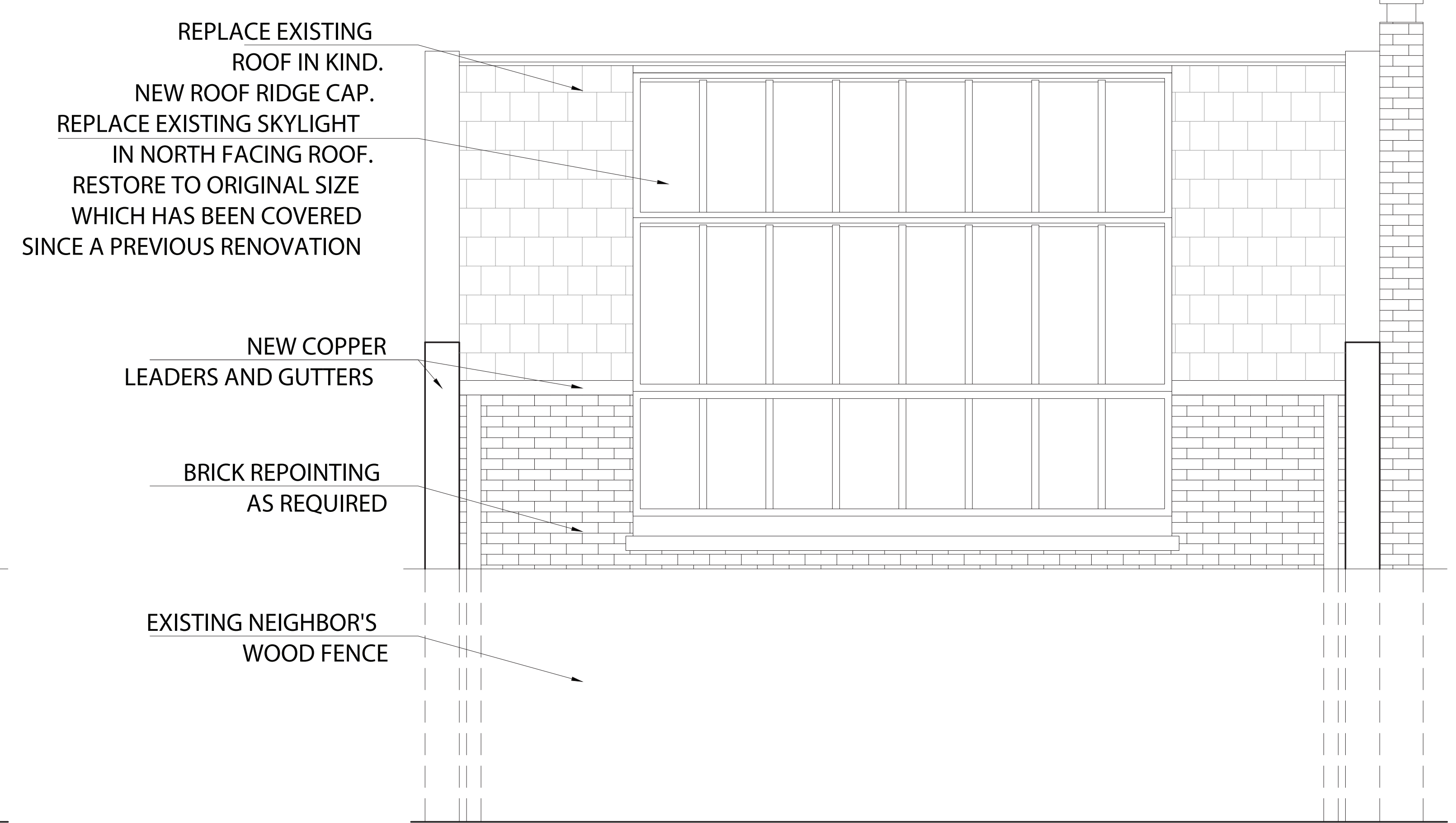

02 CARRIAGE HOUSE- PROPOSED NORTH FACING ELEVATION (REAR FACADE)
SEE SCALE BELOW

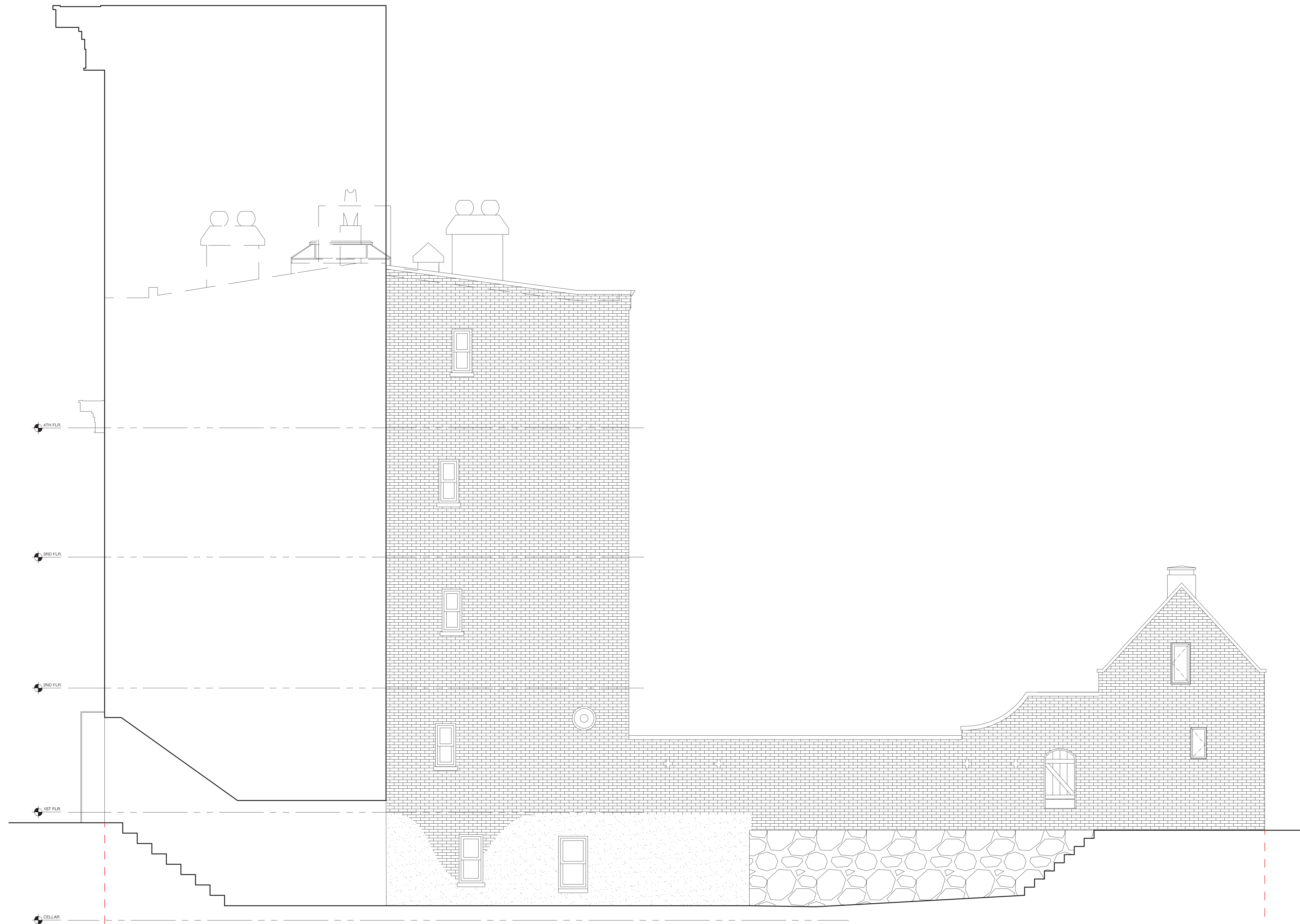

01 EXISTING EAST FACING ELEVATION AND ALLEY
SEE SCALE BELOW

DOTTED: APPROXIMATE LEVEL OF EXCAVATION AT 123 WASHINGTON PLACE BEYOND

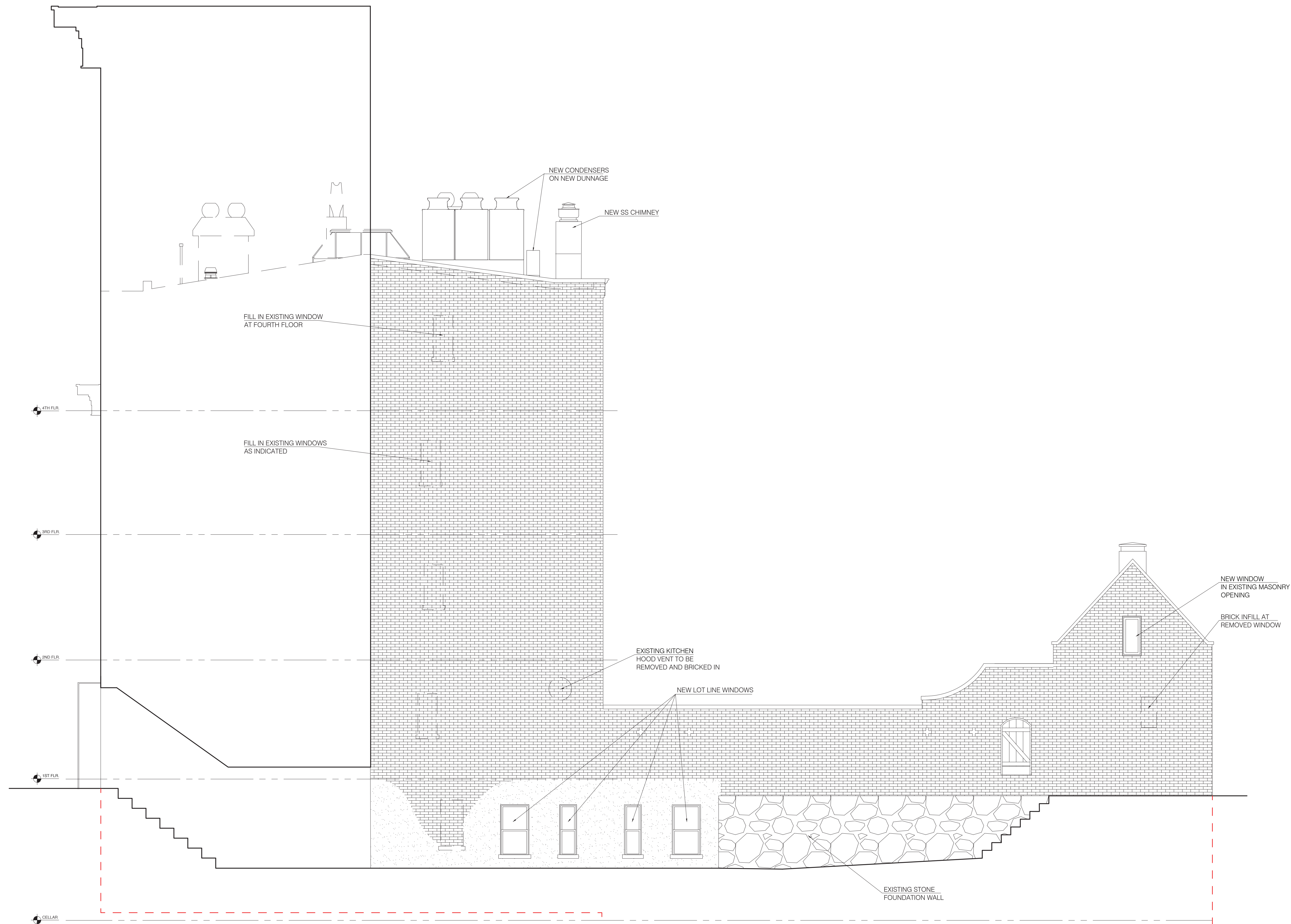

01 PROPOSED EAST FACING ELEVATION AND ALLEY
SEE SCALE BELOW

DOTTED: APPROXIMATE LEVEL OF EXCAVATION AT 123 WASHINGTON PLACE BEYOND

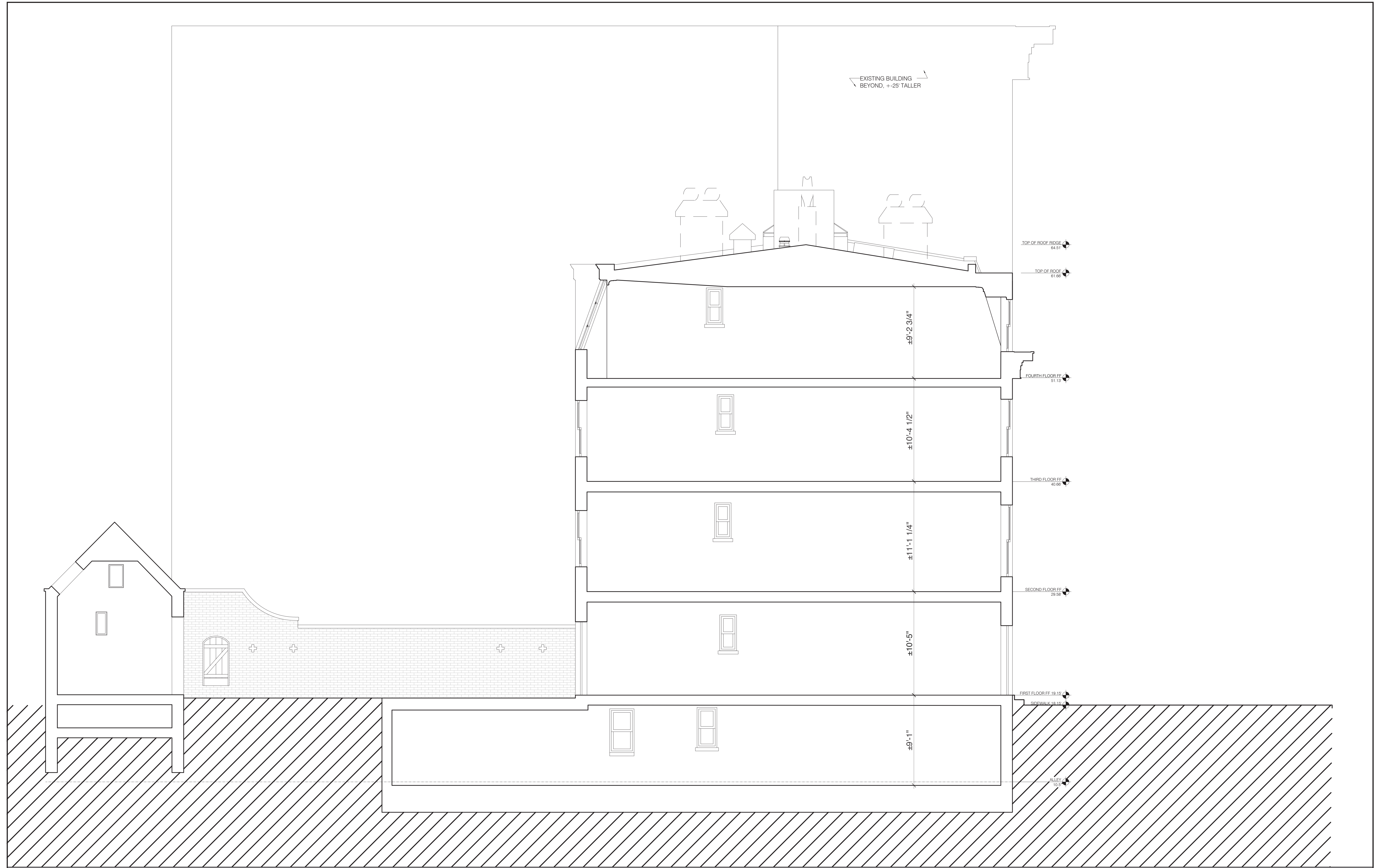

121 WASHINGTON PLACE
EXISTING SECTION



FEBRUARY 14TH
2019

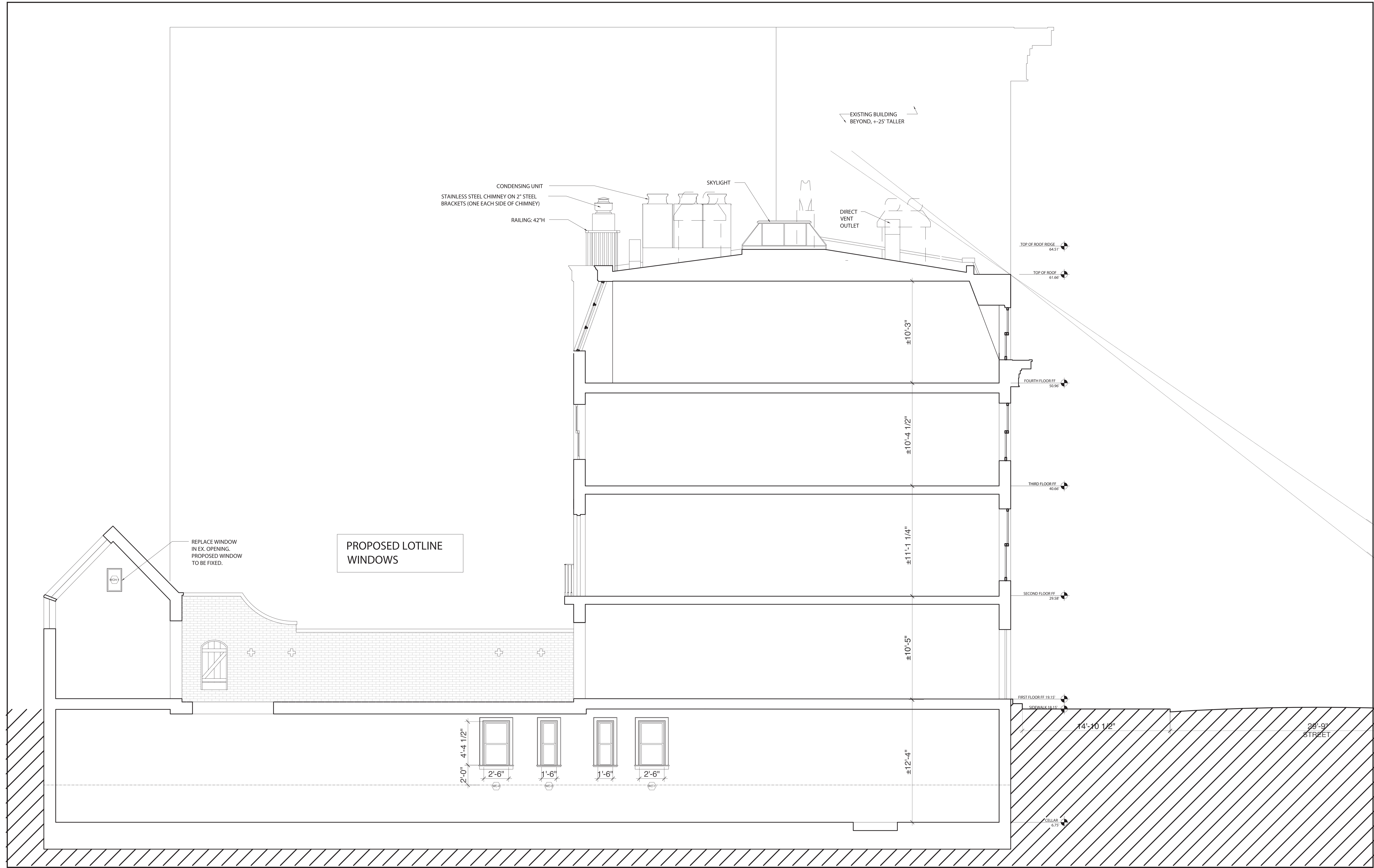

CONDENSING UNIT
 STAINLESS STEEL CHIMNEY ON 2" STEEL BRACKETS (ONE EACH SIDE OF CHIMNEY)
 RAILING: 42"H

SKYLIGHT

EXISTING BUILDING BEYOND, +25' TALLER

DIRECT VENT OUTLET

TOP OF ROOF RIDGE 64.51'

TOP OF ROOF 61.60'

FOURTH FLOOR FF 50.90'

THIRD FLOOR FF 40.60'

SECOND FLOOR FF 29.58'

FIRST FLOOR FF 19.15'

SIDEWALK 18.12'

CELLAR 6.25'

PROPOSED LOTLINE WINDOWS

REPLACE WINDOW IN EX. OPENING. PROPOSED WINDOW TO BE FIXED.

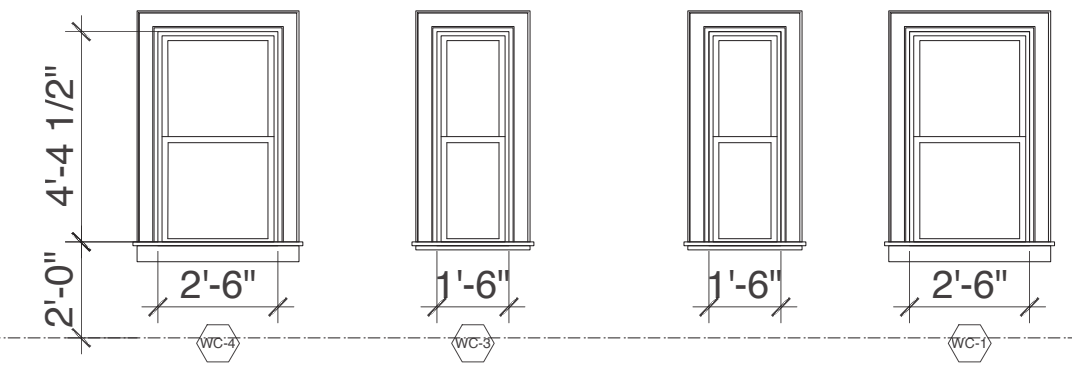

14'-10 1/2"

28'-9" STREET



121 WASHINGTON PLACE
 PROPOSED SECTION



FEBRUARY 14TH
 2019

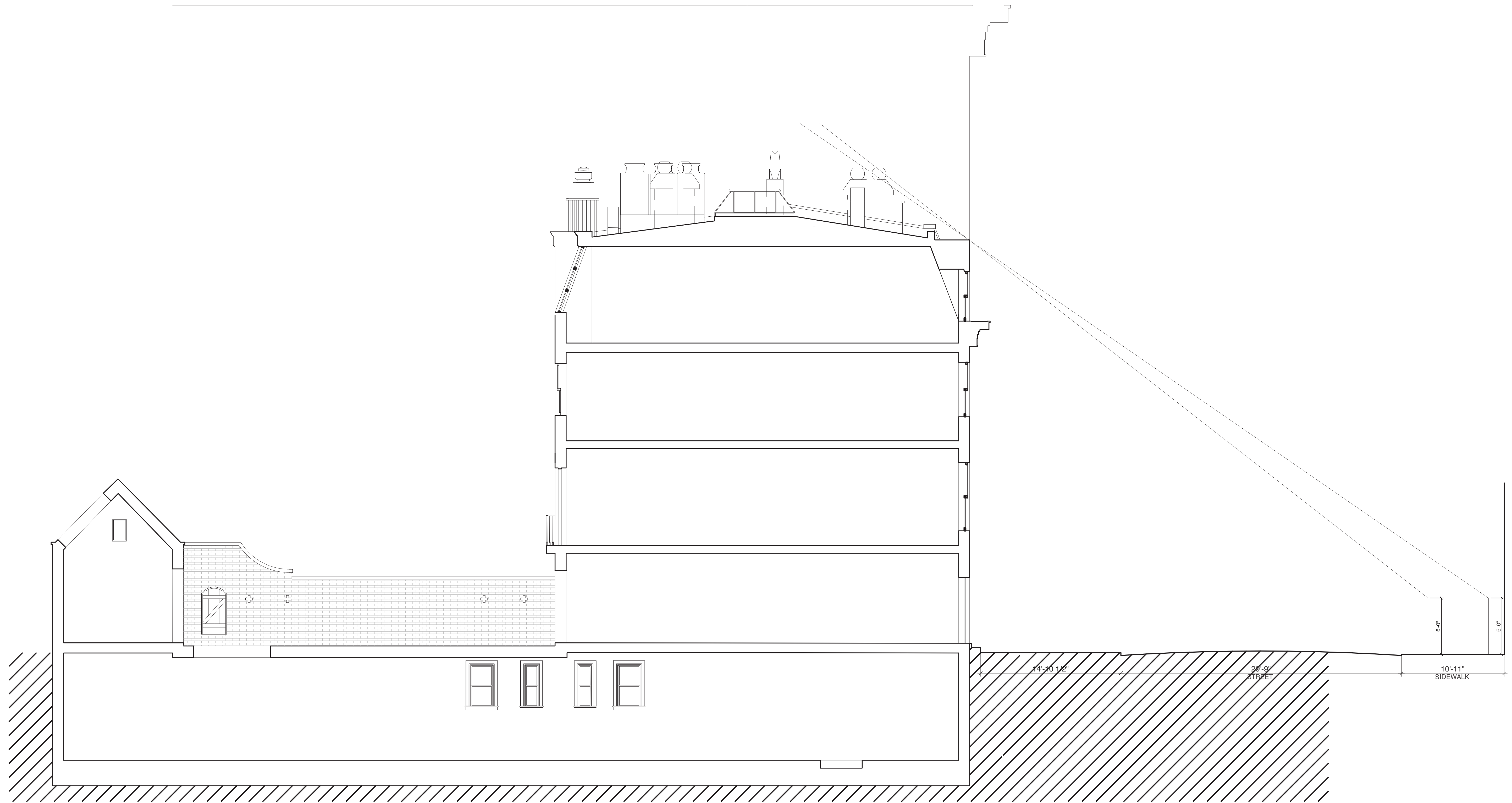

01 LPC SIGHTLINE DIAGRAM AND PROPOSED SECTION
NTS