

DXA studio  
827-831 Broadway  
November 06, 2017

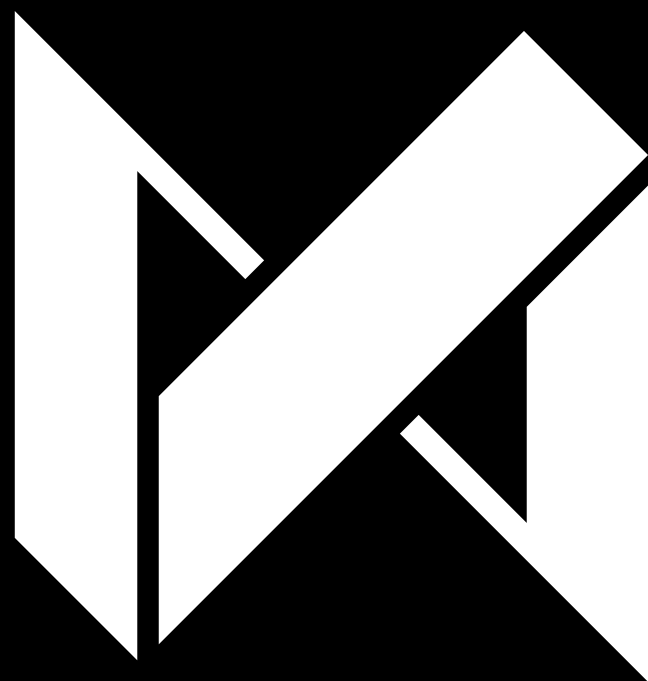



# **SITE ANALYSIS & EXISTING CONDITIONS**



**STREET VIEW**

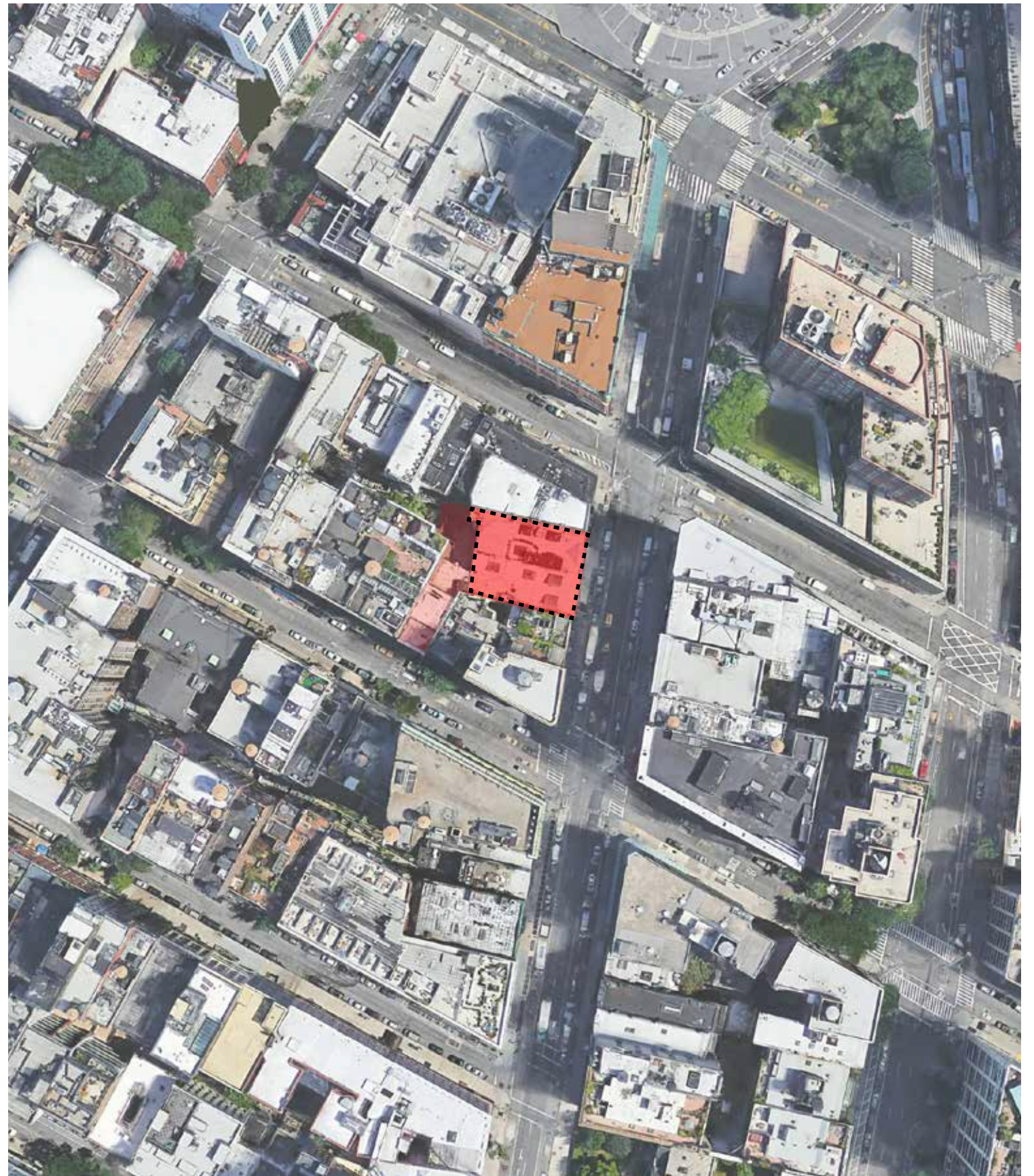

**SATELLITE VIEW OF SITE**

**827-831 BROADWAY · SITE CONTEXT**

**SCALE** As Noted  
**CLIENT** Quality Capital  
**PROJECT NUMBER** 17.32  
**DATE** November 06 2017



**DXA studio**  
894 6th Avenue  
5th Floor  
NYC 10001  
T 212 874 0567  
dxastudio.com



NYC Digital Tax Map

Effective Date : 02-14-2017 13:46:45

End Date : 02-14-2017 14:41:46

Manhattan Block: 564

Legend

- Streets
- Miscellaneous Text
- ↓ Possession Hooks
- - - Boundary Lines
- ↓ Lot Face Possession Hooks
- Regular
- - - Underwater
- Yellow Tax Lot Polygon
- Blue Condo Number
- Light Blue Tax Block Polygon



TAX MAP SHOWING LANDMARKS DESIGNATION OUTLINE

827-831 BROADWAY · SITE CONTEXT

SCALE As Noted  
 CLIENT Quality Capital  
 PROJECT NUMBER 17.32  
 DATE November 06 2017



DXA studio

894 6th Avenue  
 5th Floor  
 NYC 10001  
 T 212 874 0567

dxastudio.com



BROADWAY - 1899 (NYPL)

827-831 BROADWAY · HISTORIC PHOTOS

SCALE As Noted  
 CLIENT Quality Capital  
 PROJECT NUMBER 17.32  
 DATE November 06 2017



DXA studio  
 894 6th Avenue  
 5th Floor  
 NYC 10001  
 T 212 874 0567  
 dxastudio.com



TAX PHOTOS BUILDING - 827 CIRCA 1940



Made from the Lumiere Sigma Plate. The C. P. Goetz American Optical Co.'s Lenses were used exclusively.  
 NOS. 821 TO 835 BROADWAY, BETWEEN TWELFTH AND THIRTEENTH STREETS. AMERICAN WAIST CO.—MAY'S CAFÉ—MERCHANT'S OUTLET CO.—KAUFMAN, HATS—AL POWELL & CO., MERCHANT TAILORS—GOODYEAR RAIN COAT CO.—CAPITOL LUNCH—HAWES' HATS.

821-835 BROADWAY - 1906

827-831 BROADWAY · HISTORIC PHOTOS

SCALE As Noted  
 CLIENT Quality Capital  
 PROJECT NUMBER 17.32  
 DATE November 06 2017





TAX PHOTOS BUILDING - 827 CIRCA 1980

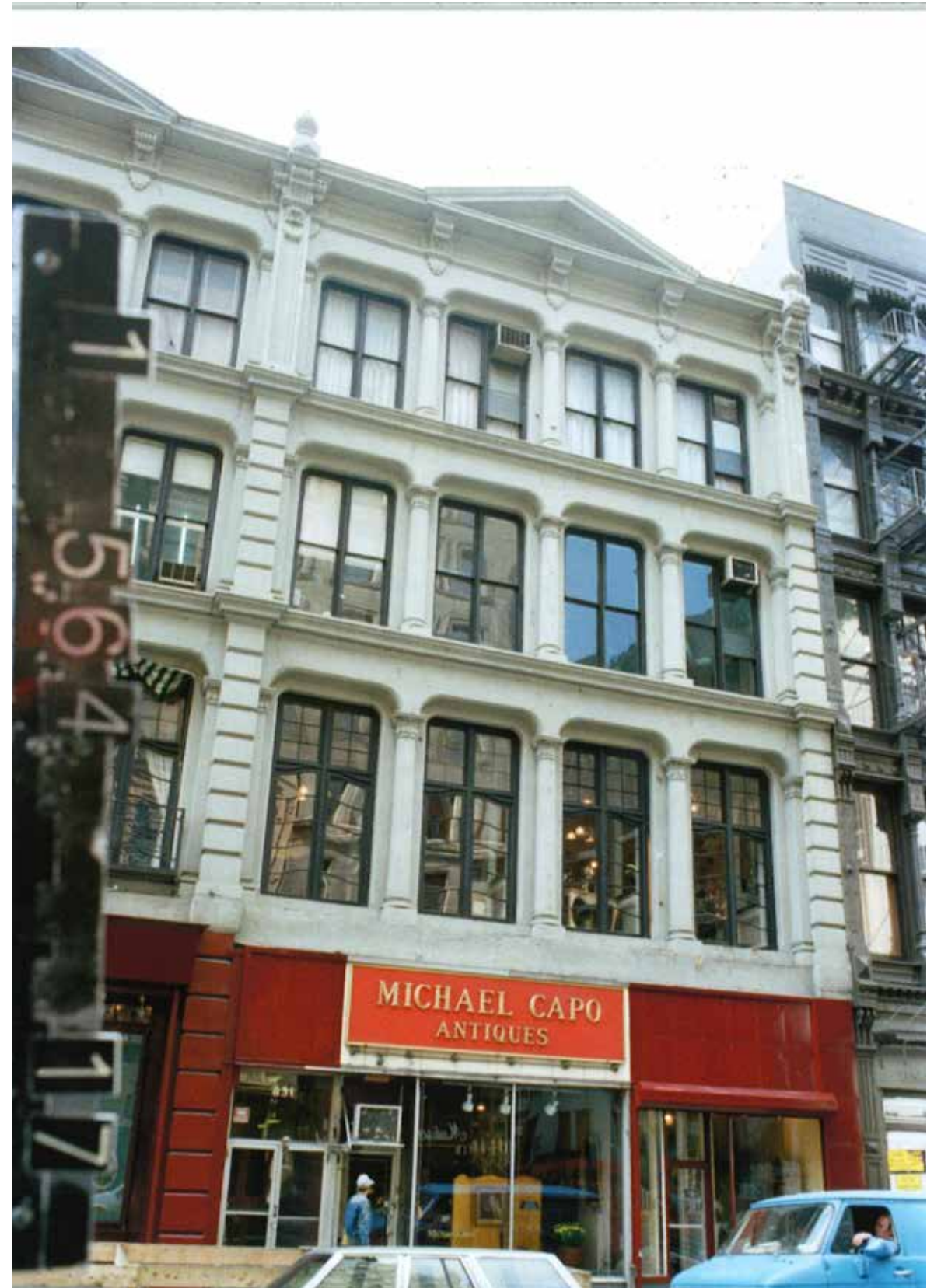

TAX PHOTOS BUILDING - 831 CIRCA 1980

827-831 BROADWAY · HISTORIC PHOTOS

SCALE As Noted  
 CLIENT Quality Capital  
 PROJECT NUMBER 17.32  
 DATE November 06 2017



DXA studio

894 6th Avenue  
 5th Floor  
 NYC 10001  
 T 212 874 0567

dxastudio.com



**BROADWAY FACADE & STOREFRONT**

**827-831 BROADWAY · PHOTOS OF EXISTING FACADES**

**SCALE** As Noted  
**CLIENT** Quality Capital  
**PROJECT NUMBER** 17.32  
**DATE** November 06 2017



**DXA studio**  
 894 6th Avenue  
 5th Floor  
 NYC 10001  
 T 212 874 0567  
 dxastudio.com





**EAST 12TH STREET FACADE & STOREFRONT**

**(NOT DESIGNATED) · PHOTOS OF EXISTING FACADES**

**SCALE** As Noted  
**CLIENT** Quality Capital  
**PROJECT NUMBER** 17.32  
**DATE** November 06 2017



**DXA studio** 894 6th Avenue  
 5th Floor  
 NYC 10001  
 T 212 874 0567  
 dxastudio.com



BROADWAY ELEVATION PHOTOMONTAGE



**DXA studio**  
 894 6th Avenue  
 5th Floor  
 NYC 10001  
 T 212 874 0567  
 dxastudio.com

827-831 BROADWAY · SURROUNDING BUILDINGS

**SCALE** As Noted  
**CLIENT** Quality Capital  
**PROJECT NUMBER** 17.32  
**DATE** November 06 2017

**10**



1



2



3



4



5



6



827-831 BROADWAY · TALL SURROUNDING BUILDINGS

<b>SCALE</b>	As Noted
<b>CLIENT</b>	Quality Capital
<b>PROJECT NUMBER</b>	17.32
<b>DATE</b>	November 06 2017





DESIGNATION OUTLINE

827-831 BROADWAY · SITE PLAN

SCALE As Noted  
 CLIENT Quality Capital  
 PROJECT NUMBER 17.32  
 DATE November 06 2017



**DXA studio**  
 894 6th Avenue  
 5th Floor  
 NYC 10001  
 dxastudio.com T 212 874 0567



# **HISTORY & INSPIRATION**



827-831 BROADWAY · HISTORY & INSPIRATION - ABSTRACT EXPRESSIONIST ARTIST STUDIOS & HANGOUTS - MID 20TH CENTURY



**DXA studio**  
894 6th Avenue  
5th Floor  
NYC 10001  
T 212 874 0567  
dxastudio.com

**SCALE** As Noted  
**CLIENT** Quality Capital  
**PROJECT NUMBER** 17.32  
**DATE** November 06 2017

**NEW YORK SCHOOL  
ARTISTS**



JACKSON POLLOCK

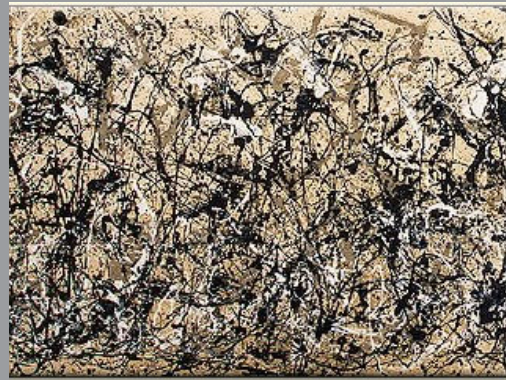

MARK ROTHKO



FRANZ KLINE



ARSHILE GORKY



ADOLF GOTTLIEB



HELEN FRANKENTHALER

**827-831 BROADWAY  
CONTRIBUTING ARTISTS**



LARRY POONS



PAUL JENKINS



ELAINE DE KOONING



JULES OLITSKI

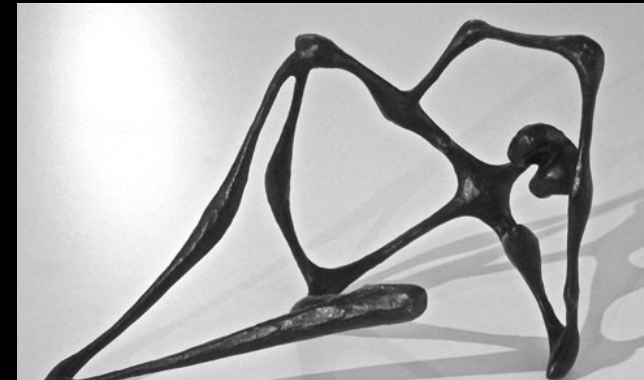

HERBERT FERBER



**827-831 BROADWAY · HISTORY & INSPIRATION: ABSTRACT EXPRESSIONISM**



**DXA studio**  
894 6th Avenue  
5th Floor  
NYC 10001  
T 212 874 0567  
dxastudio.com

**SCALE** As Noted  
**CLIENT** Quality Capital  
**PROJECT NUMBER** 17.32  
**DATE** November 06 2017

WILLEM DE KOONING IN  
BROADWAY STUDIO 1958 - 1963

**BLACK & WHITE  
ABSTRACT  
- LATE 1940s**



**FIGURATIVE  
REPRESENTATION  
- EARLY 1950s**

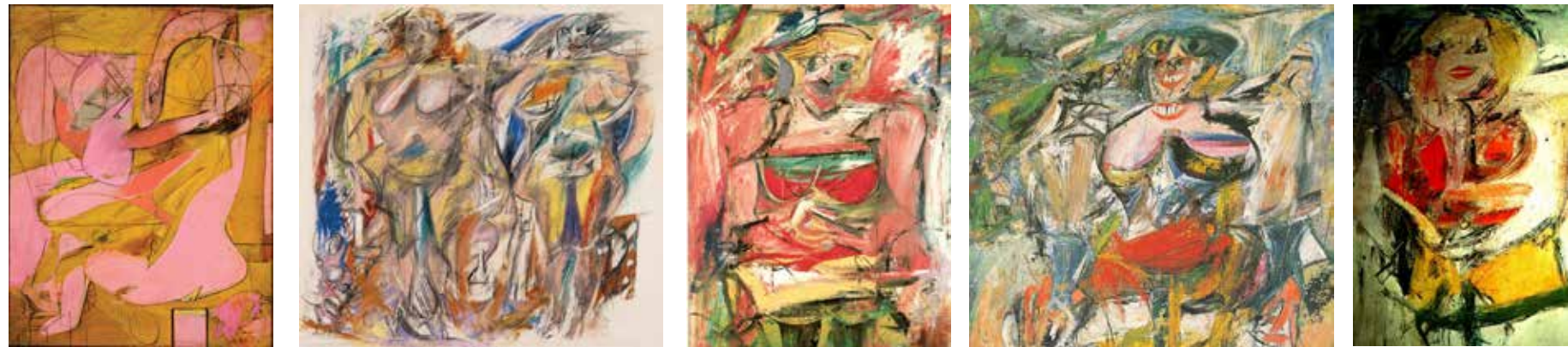

**URBAN LANDSCAPE  
REPRESENTATION  
- LATE 1950s**



**RURAL LANDSCAPE  
REPRESENTATION  
- EARLY 1960s**



**PAINTINGS WILLEM DE KOONING  
PRODUCED IN 831 BROADWAY  
- ROSY - FINGERED DAWN AT LOUSE POINT  
- DOOR TO THE RIVER**

**DE KOONING AS A MICROCOSM OF THE MOVEMENT**

827-831 BROADWAY · HISTORY & INSPIRATION - DE KOONING



**DXA studio** 894 6th Avenue  
5th Floor  
NYC 10001  
T 212 874 0567  
dxastudio.com

**SCALE** As Noted  
**CLIENT** Quality Capital  
**PROJECT NUMBER** 17.32  
**DATE** November 06 2017



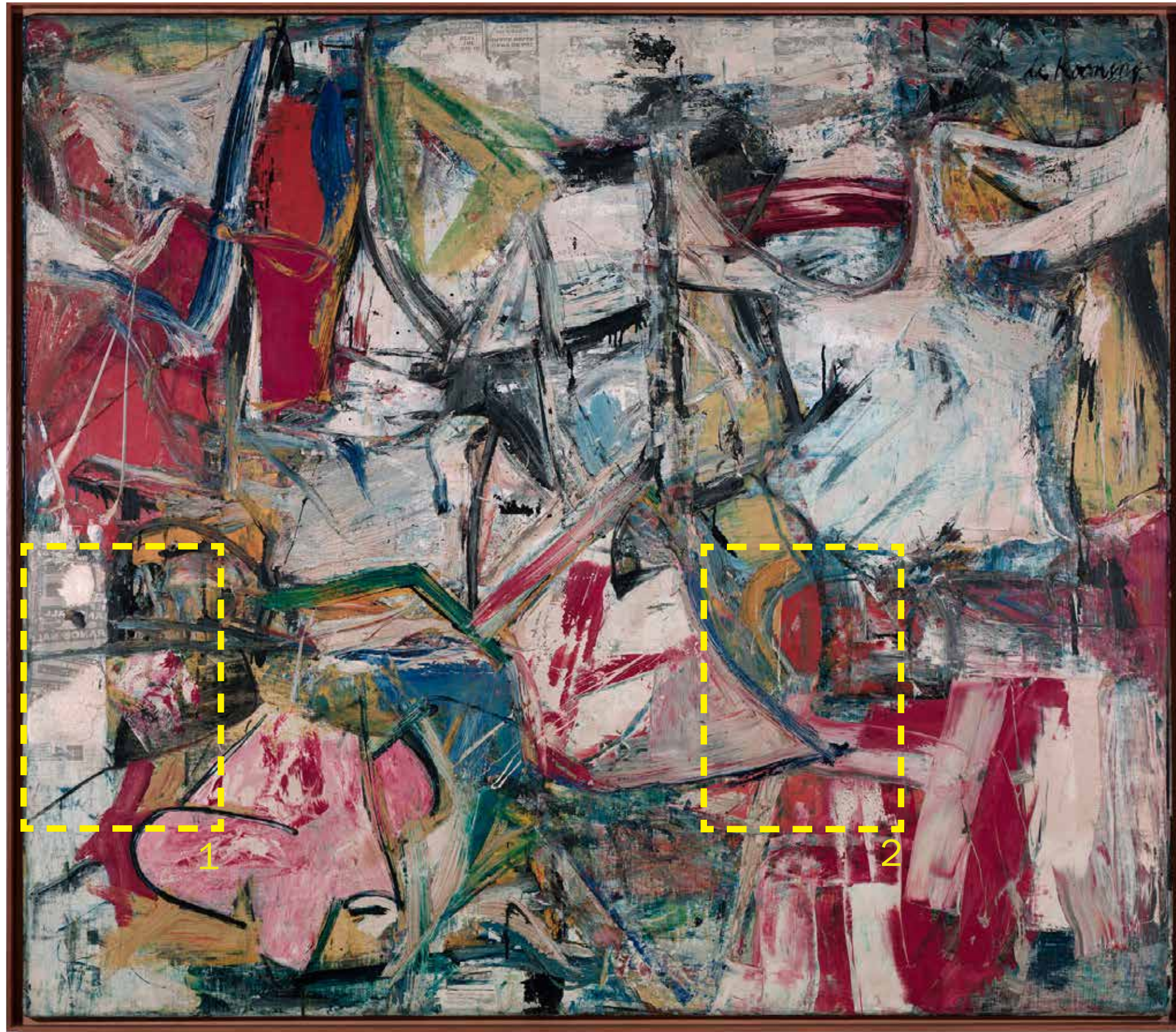

PAINING AS CONSTRUCTION: WILLEM DE KOONING - GOTHAM NEWS

827-831 BROADWAY · HISTORY & INSPIRATION - DE KOONING

ENCYCLOPEDIA - DEVICES ARCHITECTURAL

SCALE As Noted  
CLIENT Quality Capital  
PROJECT NUMBER 17.32  
DATE November 06 2017



DXA studio

894 6th Avenue  
5th Floor  
NYC 10001  
T 212 874 0567

dxastudio.com

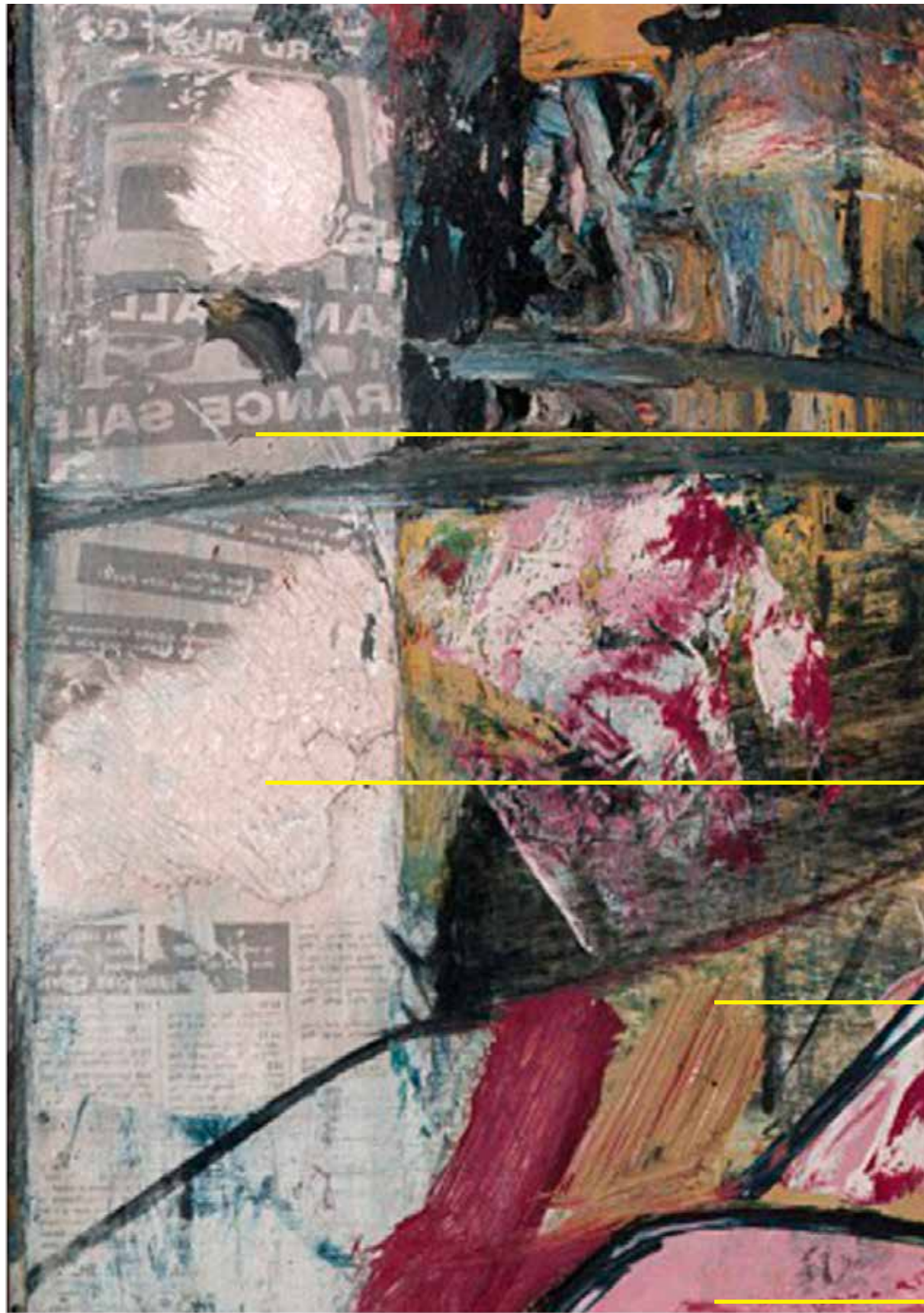

DETAIL 1

GESTURAL STROKES

MIXED MEDIA: NEWSPAPER CLIPPINGS

IMPASTO PAINTING TECHNIQUES

THICK BRUSH STROKES, SHARP GEOMETRY

TRANSPARENCY & OPACITY

FIGURATIVE REPRESENTATION

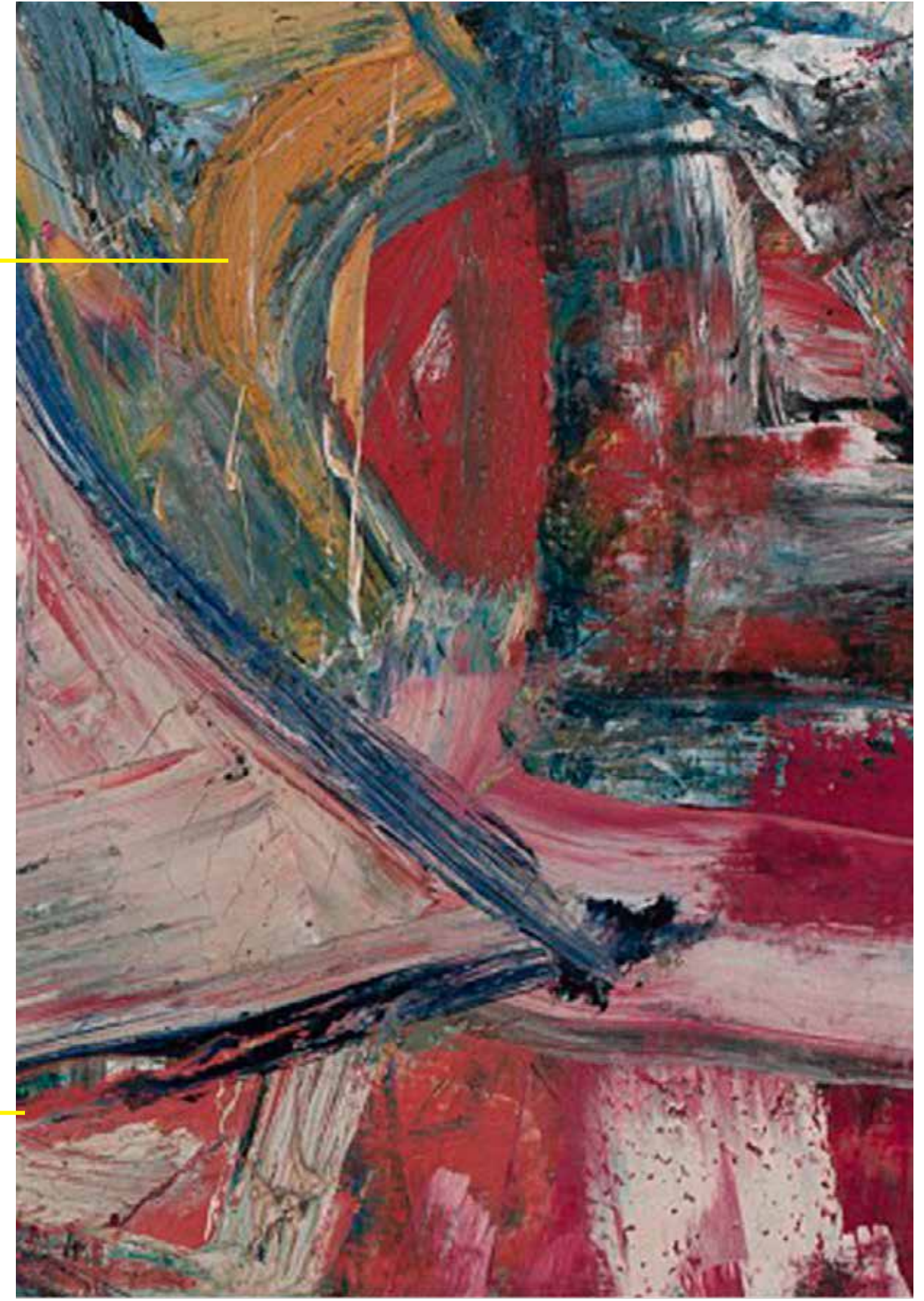

DETAIL 2

827-831 BROADWAY · HISTORY & INSPIRATION - DE KOONING



**DXA studio**

894 6th Avenue  
5th Floor  
NYC 10001  
T 212 874 0567

dxastudio.com

**SCALE**  
**CLIENT**  
**PROJECT NUMBER**  
**DATE**

As Noted  
Quality Capital  
17.32  
November 06 2017

**18**

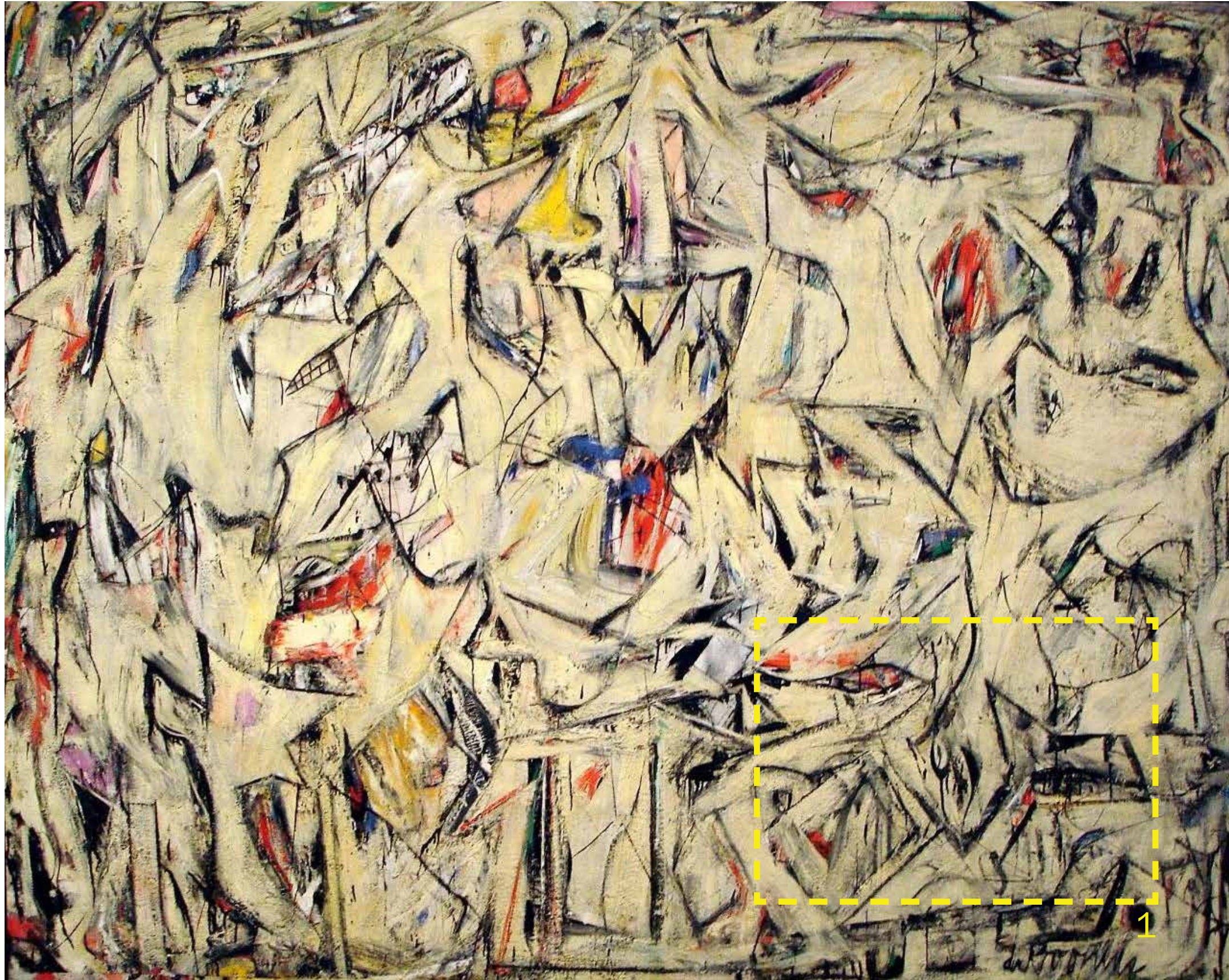

**PAINTING AS CONSTRUCTION: WILLEM DE KOONING - EXCAVATION**

**827-831 BROADWAY · HISTORY & INSPIRATION - DE KOONING**

<b>SCALE</b>	As Noted
<b>CLIENT</b>	Quality Capital
<b>PROJECT NUMBER</b>	17.32
<b>DATE</b>	November 06 2017



**DXA studio**

894 6th Avenue  
5th Floor  
NYC 10001  
T 212 874 0567

dxastudio.com



**PAINTING INPIRATION**

SILVANA MANGANO IN BITTER RICE  
GIUSEPPE DE SANTIS - 1949

THE FILM AND IMAGES OF THE  
ITALIAN ACTRESS TOILING IN  
A RICE FIELD FOR THE 1949  
NEOREALIST FILM SERVED A POINT  
OF DEPARTURE FOR WILLEM DE  
KOONINGS PAINTING "EXCAVATION".



**FIGURATIVE REPRESENTATION;**  
CALLIGRAPHIC LINES DEFINE  
ANATOMICAL PARTS

**VERTICAL ALIGNMENT**  
DIVIDING PAINTING INTO  
APPROXIMATING ROWS

**EXPRESSIVE BRUSHWORK WITH**  
BRIGHT BACKGROUND TEXTURES

**ORGANIZATION OF SPACE INTO**  
LOOSE SLIDING PLANES WITH  
OPEN CONTOURS

DETAIL 1



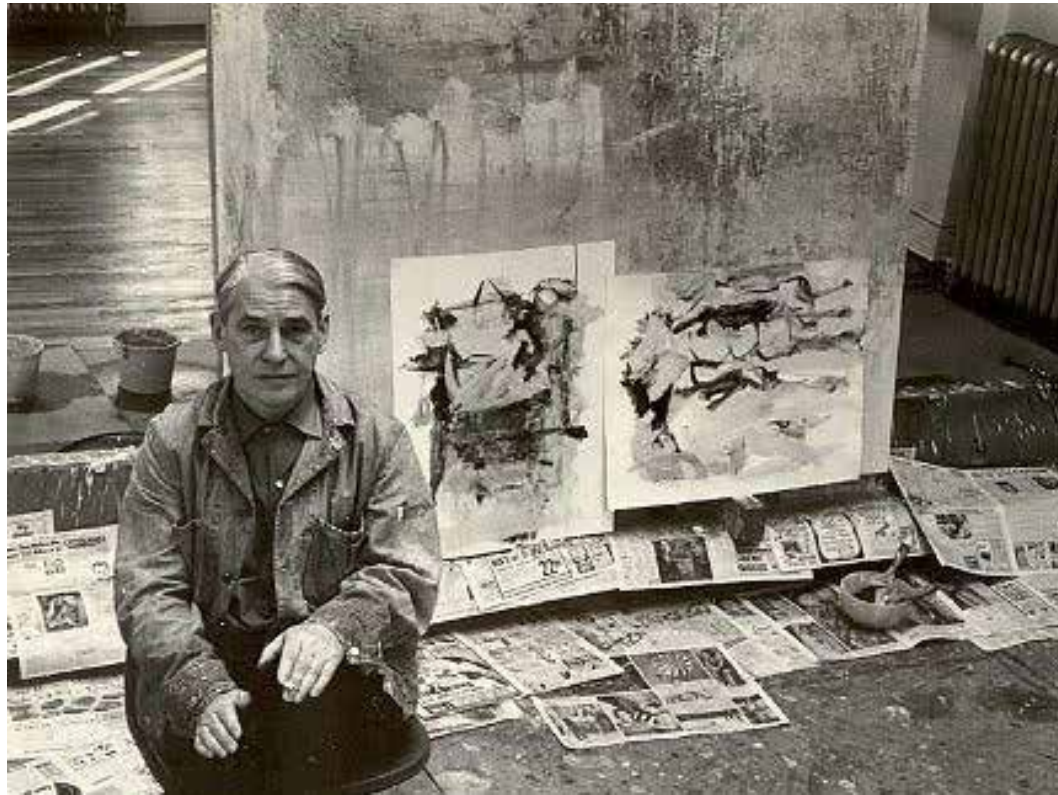

WILLEM DE KOONING - 1962 (FRED MCDARRAH)

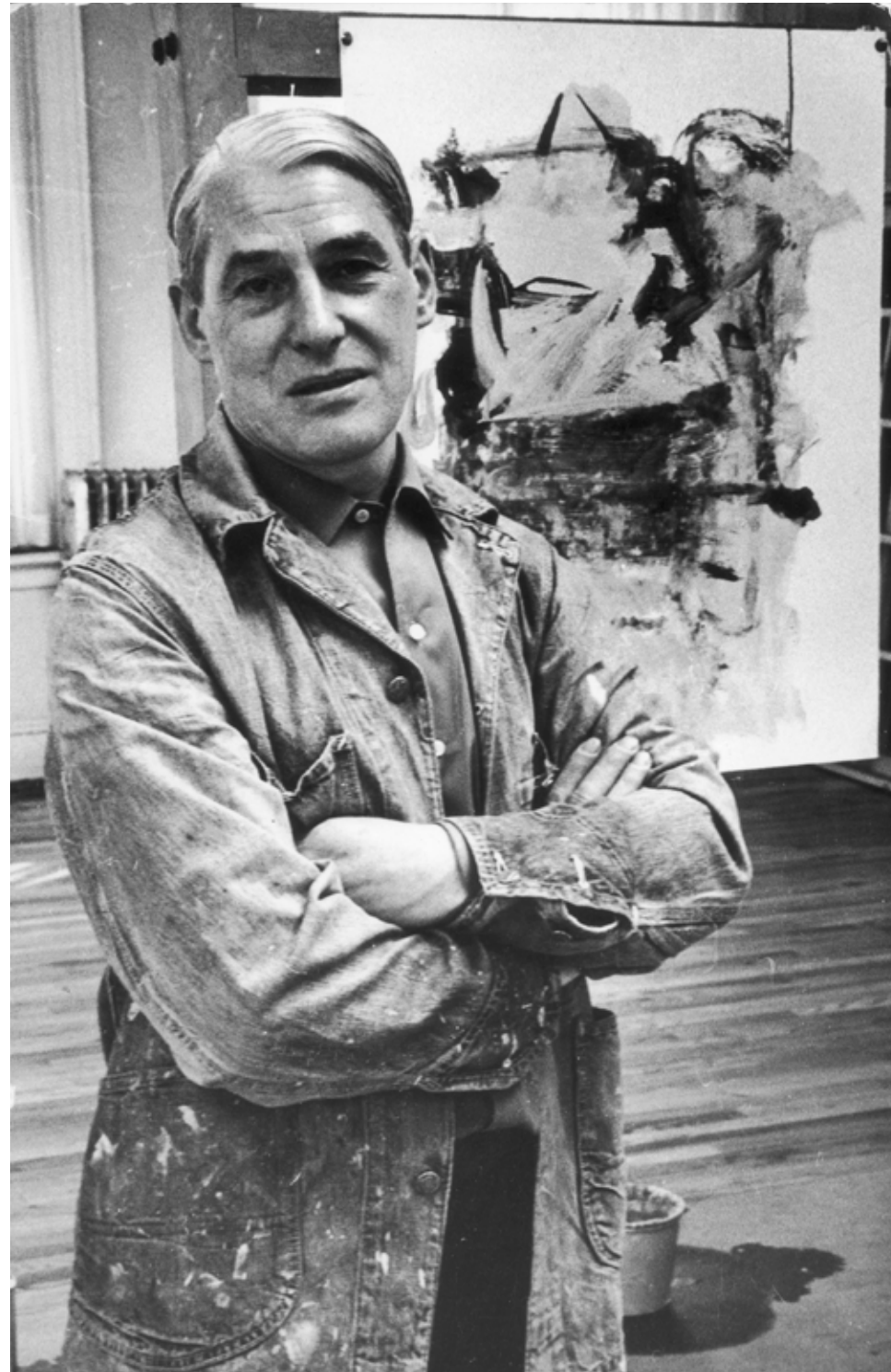

WILLEM DE KOONING - UNKNOWN



ELAINE DE KOONING - 1963 (FRED MCDARRAH)

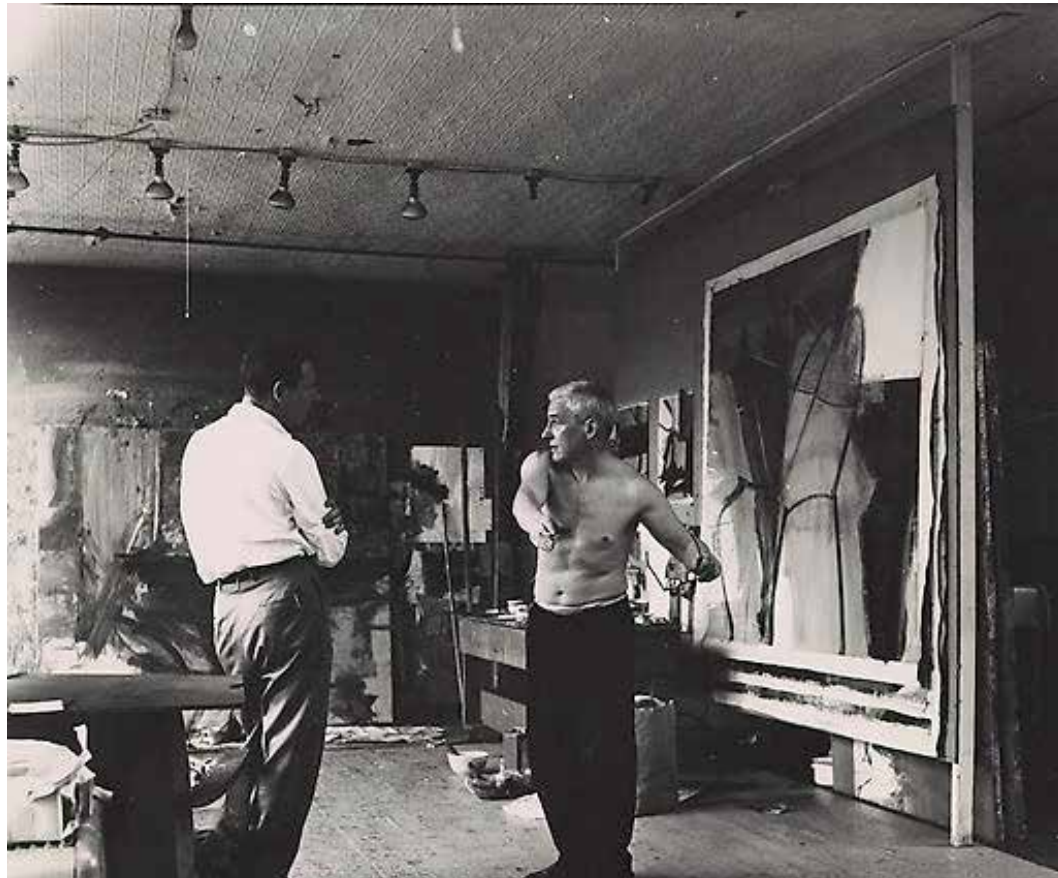

WILLEM DE KOONING UNKNOWN

827-831 BROADWAY · HISTORIC PHOTOS OF ARTISTS WORKING IN BROADWAY STUDIOS



**DXA studio**

894 6th Avenue  
5th Floor  
NYC 10001  
T 212 874 0567

dxastudio.com

**SCALE**  
**CLIENT**  
**PROJECT NUMBER**  
**DATE**

As Noted  
Quality Capital  
17.32  
November 06 2017

**21**



LARRY POONS/ FRANK STELLA - VOGUE - 1967



LARRY POONS - UNKNOWN



PAUL JENKINS - 1964 (JOHN D SCHIFF)



PAUL JENKINS - 1964 (JOHN D SCHIFF)

**LARGE SKYLIGHTS PROVIDING NATURAL ILLUMINATION OF STUDIOS**

827-831 BROADWAY · HISTORIC PHOTOS OF ARTISTS WORKING IN BROADWAY STUDIOS



**DXA studio**

894 6th Avenue  
5th Floor  
NYC 10001  
T 212 874 0567

dxastudio.com

**SCALE** As Noted  
**CLIENT** Quality Capital  
**PROJECT NUMBER** 17.32  
**DATE** November 06 2017



KUNSTHAUS BREGENZ, VORARLBERG, AUSTRIA - PETER ZUMTHOR  
 - LAYERING, DEPTH & MOTION



SUZHOU CHAPEL, SUZHOU, CHINA - NERU AND HU  
 - DYNAMIC & EVERCHANGING



LABAN DANCE CENTER, LONDON - HERZOG AND DE MEURON  
 - BLURRING & BLENDING

827-831 BROADWAY · ARCHITECTURAL PRECEDENTS: ANALOGOUS TO PAINTING TECHNIQUES



**DXA studio** 894 6th Avenue  
 5th Floor  
 NYC 10001  
 T 212 874 0567  
 dxastudio.com

**SCALE** As Noted  
**CLIENT** Quality Capital  
**PROJECT NUMBER** 17.32  
**DATE** November 06 2017



MIRROR HOUSE, NETHERLANDS - REMCO SIEBRING  
- REFLECTION & TRANSPARENCY ON SINGLE PLANE



CASTLE DOWNS PARK PAVILION, EDMONTON, CANADA - GH3  
- FOLDING & DISTORTION

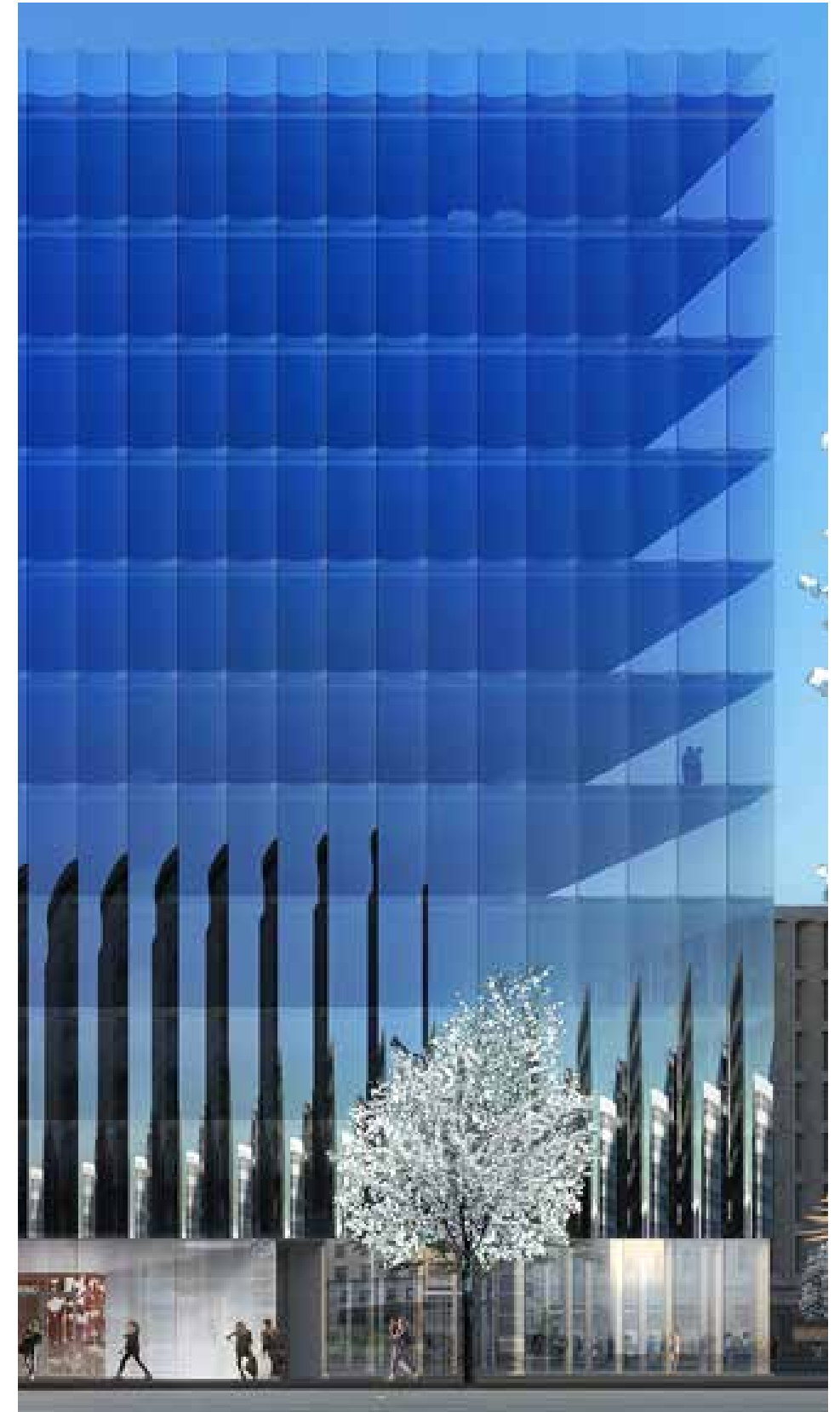

2050 M STREET, WASHINGTON DC - REX  
- DISTORTING, FRAMING & ROTATING

827-831 BROADWAY · ARCHITECTURAL PRECEDENTS: REFLECTION, OPACITY & DISTORTION



**DXA studio**

894 6th Avenue  
5th Floor  
NYC 10001  
T 212 874 0567

dxastudio.com

**SCALE**  
**CLIENT**  
**PROJECT NUMBER**  
**DATE**

As Noted  
Quality Capital  
17.32  
November 06 2017

**24**





# **FACADE DESIGN**

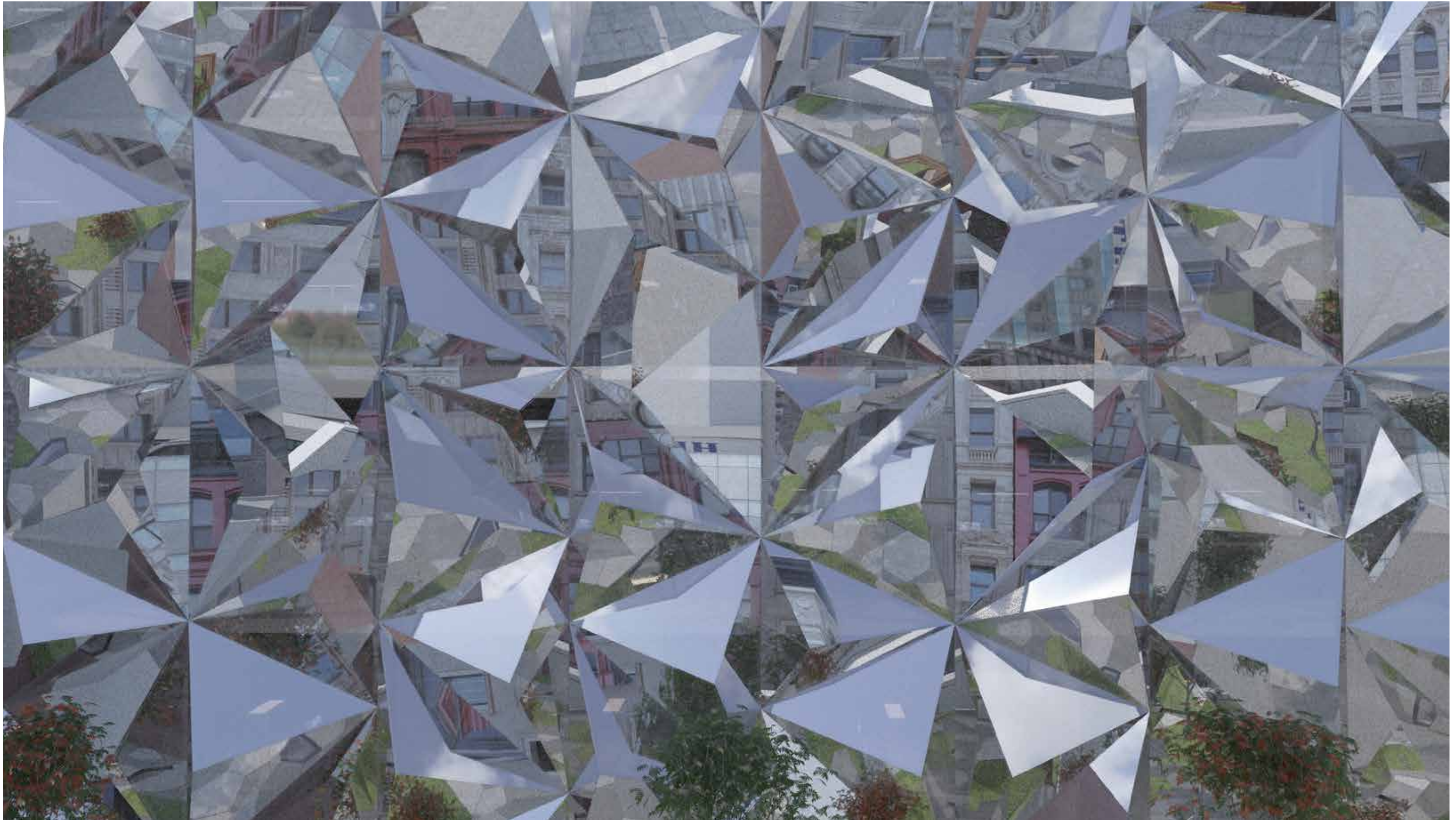

827-831 BROADWAY - FACADE VISUALIZATION - REFLECTION



**DXA studio**

894 6th Avenue  
5th Floor  
NYC 10001  
T 212 874 0567

[dxastudio.com](http://dxastudio.com)

<b>SCALE</b>	As Noted
<b>CLIENT</b>	Quality Capital
<b>PROJECT NUMBER</b>	17.32
<b>DATE</b>	November 06 2017

**26**

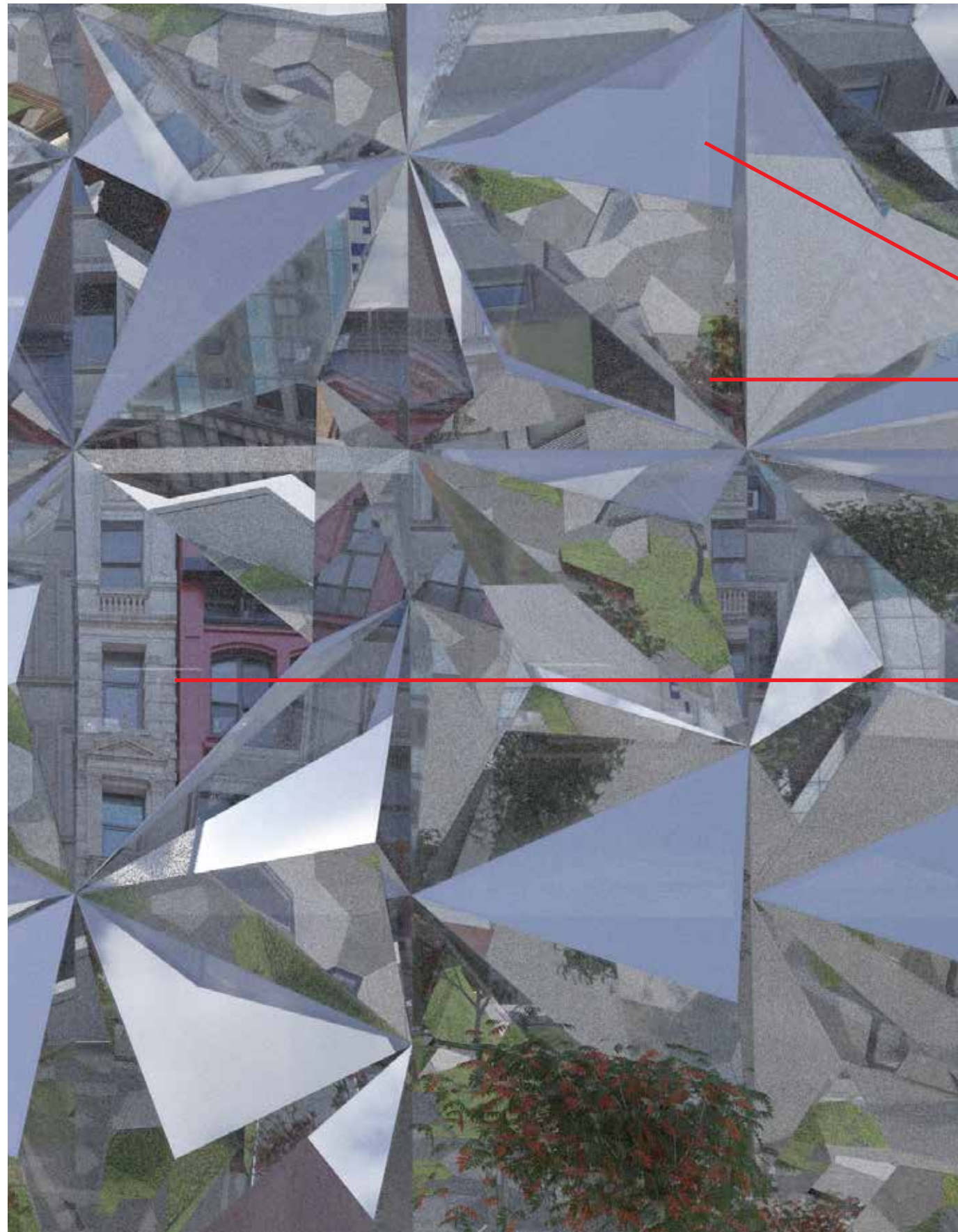

**LANDSCAPE AND PLANTING REFLECTION;**  
REPRESENTATIVE OF DE KOONINGS RURAL AND  
PASTORAL LANDSCAPE PHASE (EARLY 1960`S)

**BUILDING AND CITYSCAPE REFLECTION;**  
REPRESENTATIVE OF DE KOONINGS URBAN LANDSCAPE  
PHASE (LATE 1950`S)

**827-831 BROADWAY - FACADE VISUALIZATION - REFLECTION DETAIL**

**SCALE** As Noted  
**CLIENT** Quality Capital  
**PROJECT NUMBER** 17.32  
**DATE** November 06 2017



**DXA studio** 894 6th Avenue  
5th Floor  
NYC 10001  
T 212 874 0567  
dxastudio.com



827-831 BROADWAY - FACADE VISUALIZATION - STREET VIEW SOUTH



**DXA studio**

894 6th Avenue  
5th Floor  
NYC 10001  
T 212 874 0567

dxastudio.com

**SCALE** As Noted  
**CLIENT** Quality Capital  
**PROJECT NUMBER** 17.32  
**DATE** November 06 2017

**28**



827-831 BROADWAY - FACADE VISUALIZATION - VIEW WEST - STREET VIEW WEST



**DXA studio**

894 6th Avenue  
5th Floor  
NYC 10001  
T 212 874 0567

[dxastudio.com](http://dxastudio.com)

<b>SCALE</b>	As Noted
<b>CLIENT</b>	Quality Capital
<b>PROJECT NUMBER</b>	17.32
<b>DATE</b>	November 06 2017

**29**

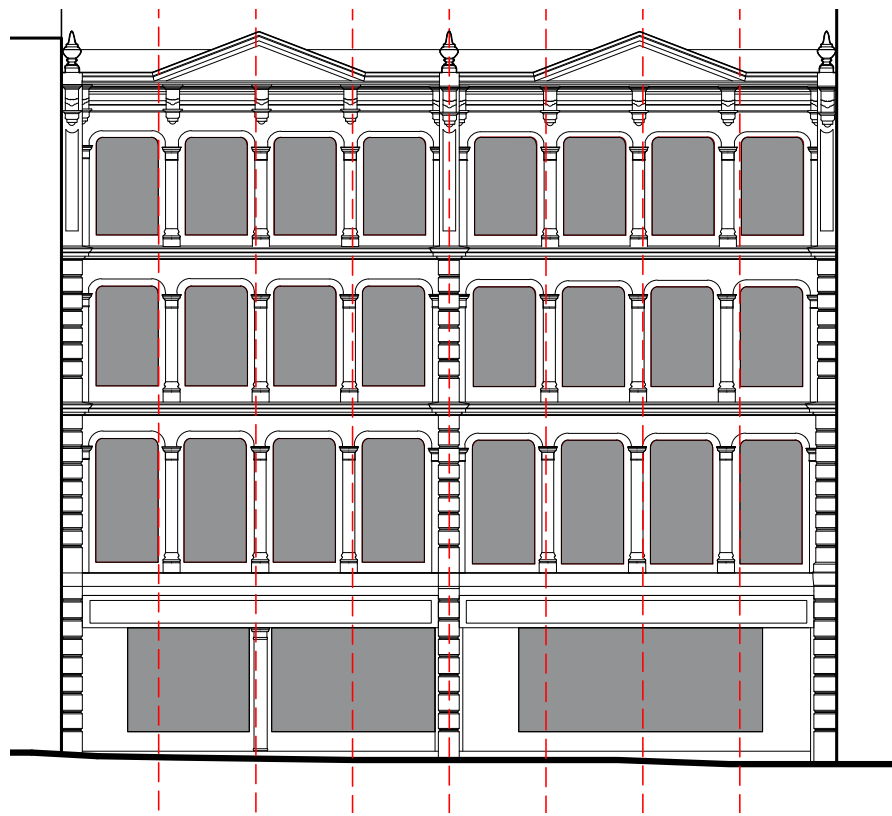

EIGHT BAY HORIZONTAL

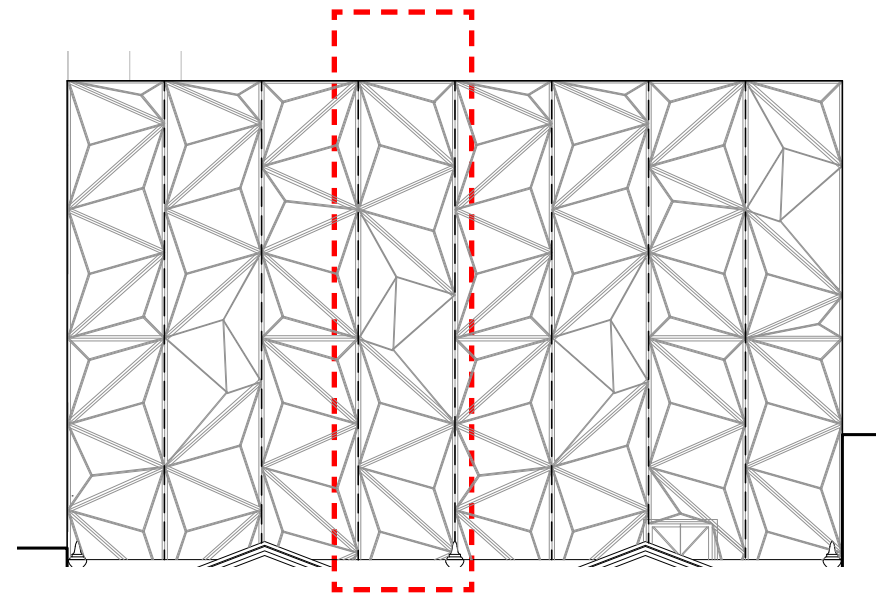

REFLECTED IN ADDTION

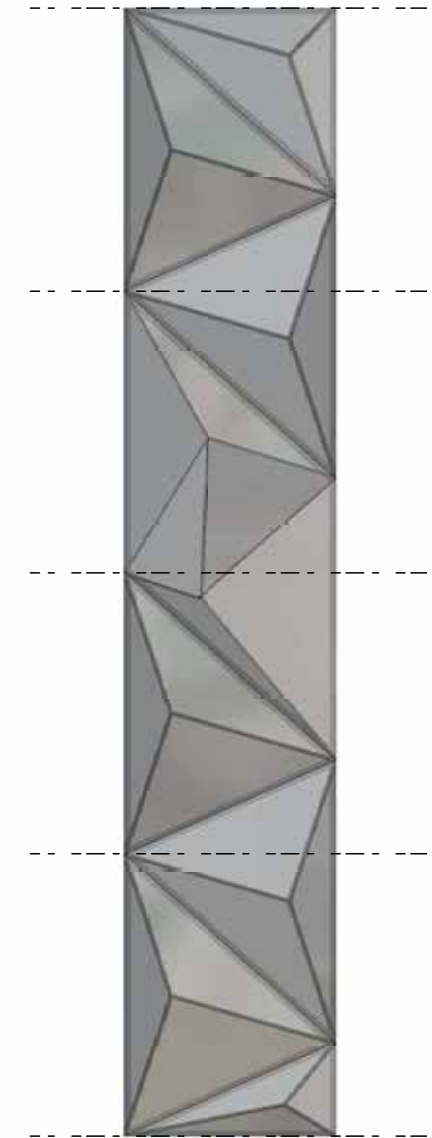

INDIVIDUAL BAY



**DXA studio**

dxastudio.com

894 6th Avenue  
5th Floor  
NYC 10001  
T 212 874 0567

827-831 BROADWAY - **FACADE HIERARCHY & RHYTHM**

**SCALE** As Noted  
**CLIENT** Quality Capital  
**PROJECT NUMBER** 17.32  
**DATE** November 06 2017

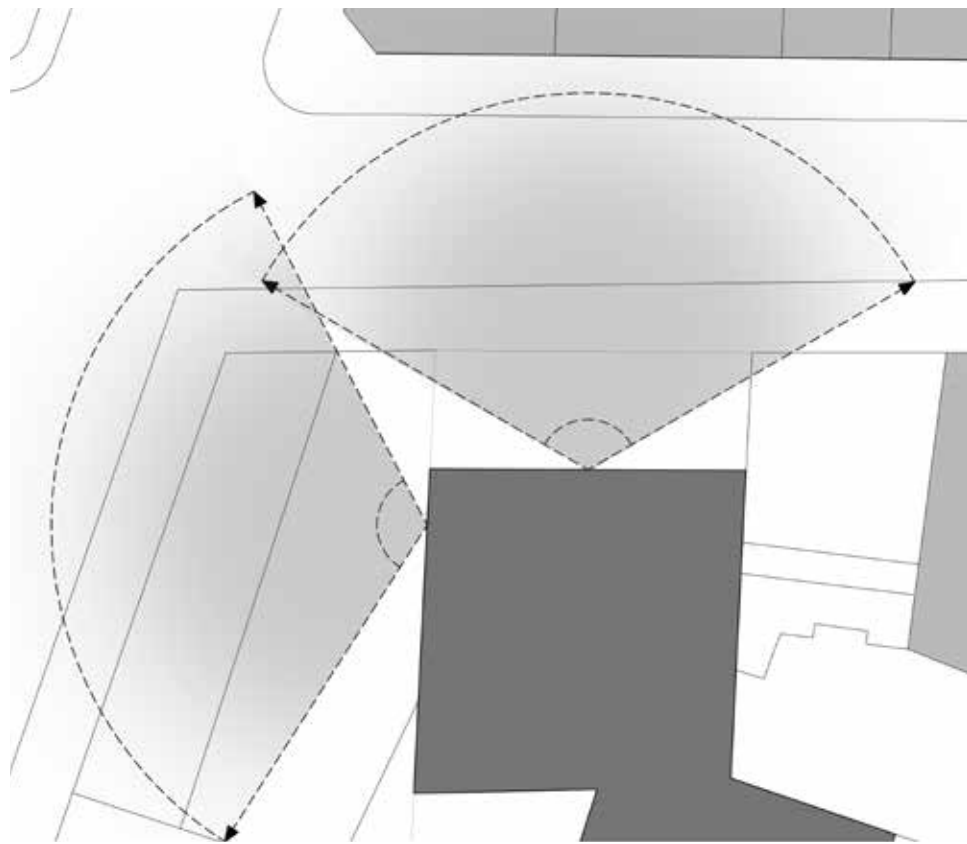

FLAT FACADE REFLECTION - PLAN

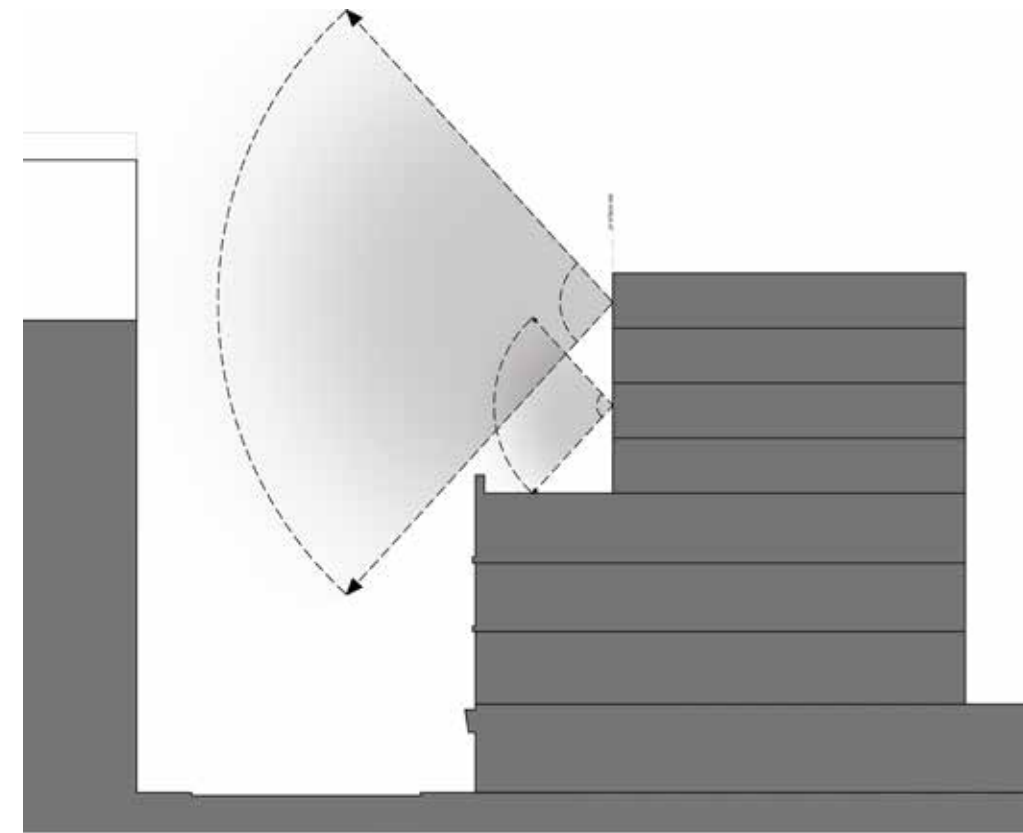

FLAT FACADE REFLECTION - SECTION

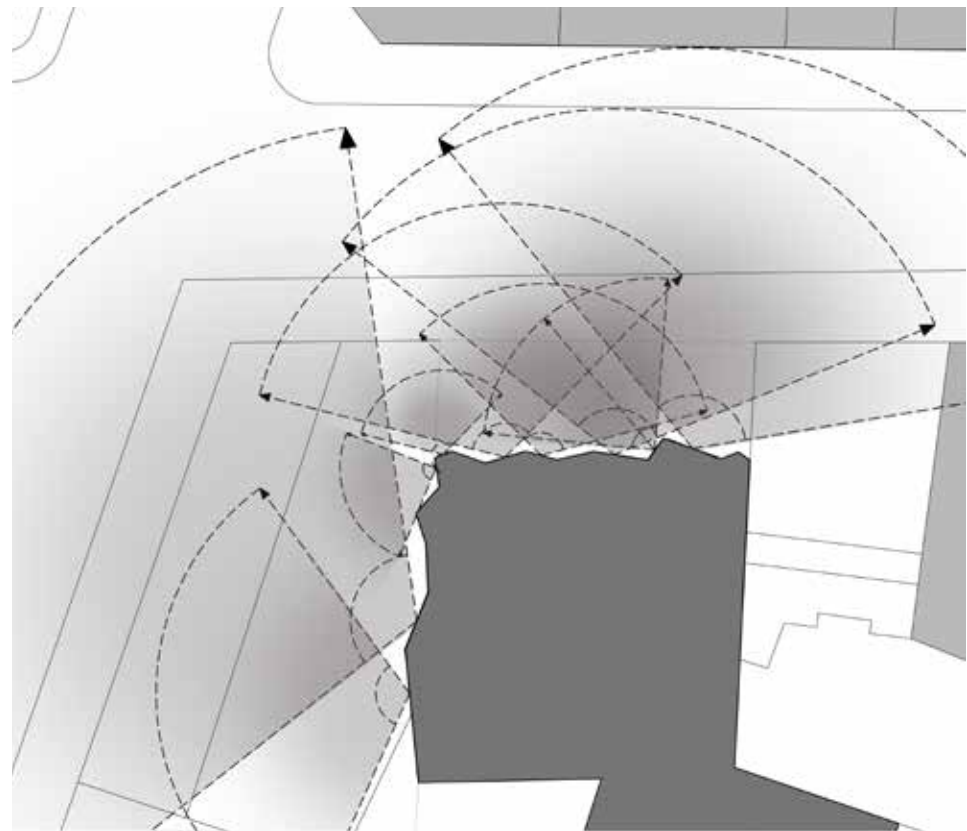

FACETED FACADE REFLECTION - PLAN

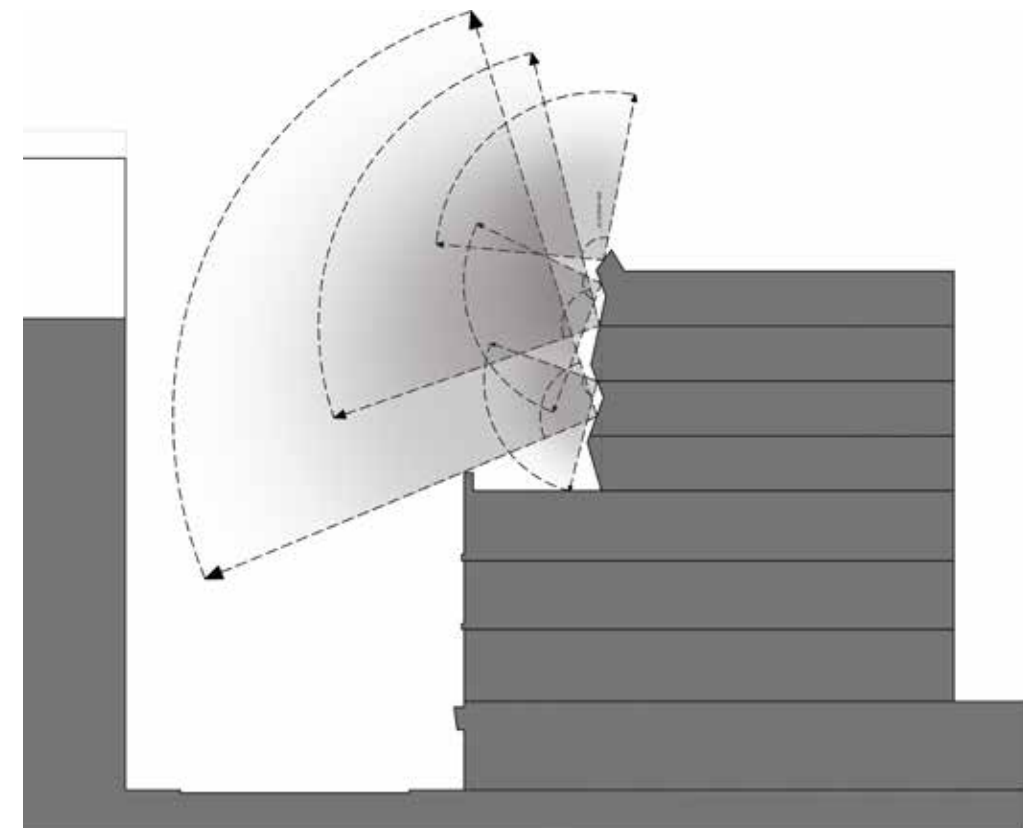

FACETED FACADE REFLECTION - SECTION

827-831 BROADWAY · REFLECTION STUDIES

SCALE As Noted  
 CLIENT Quality Capital  
 PROJECT NUMBER 17.32  
 DATE November 06 2017



**DXA** studio

894 6th Avenue  
 5th Floor  
 NYC 10001  
 T 212 874 0567

dxastudio.com

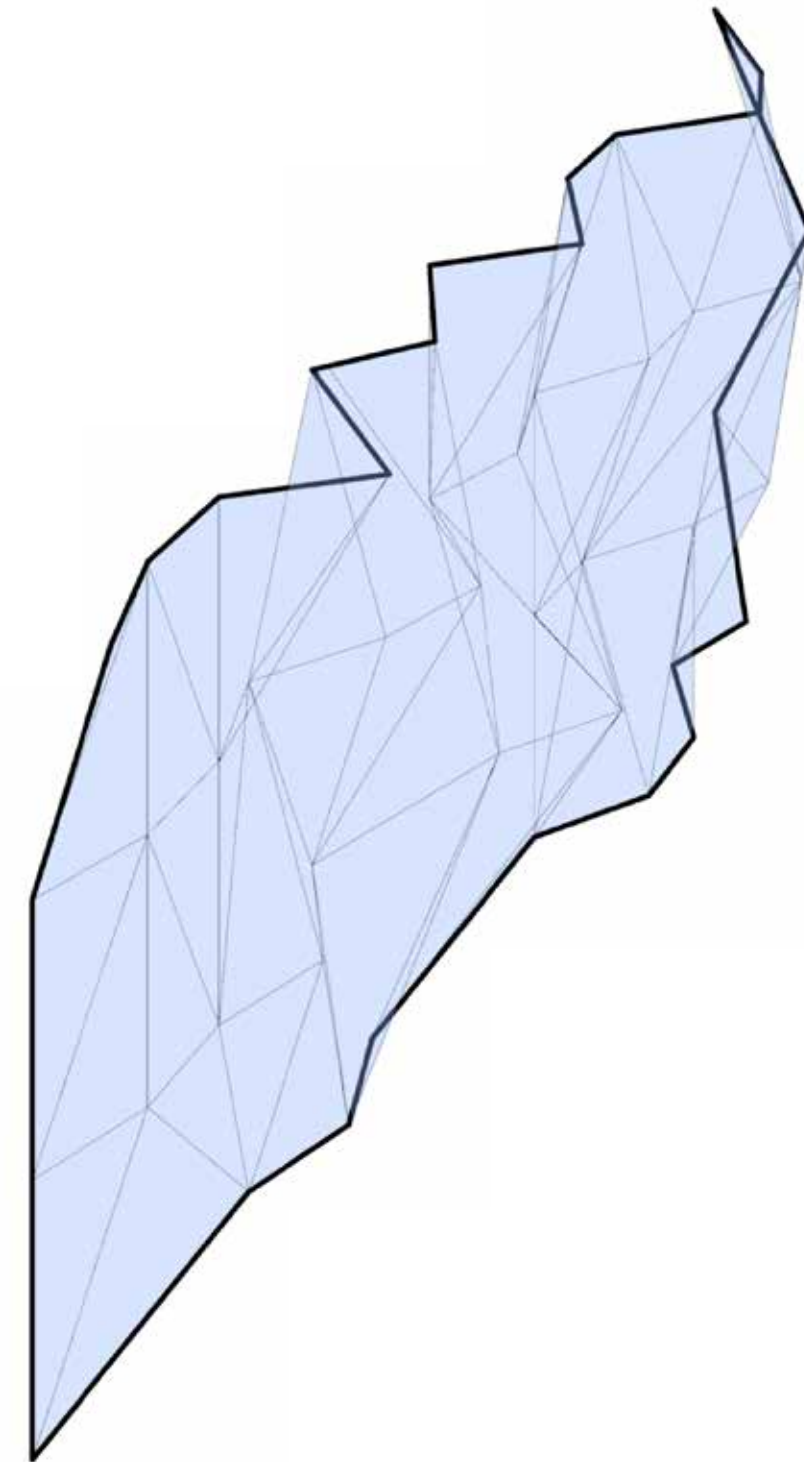
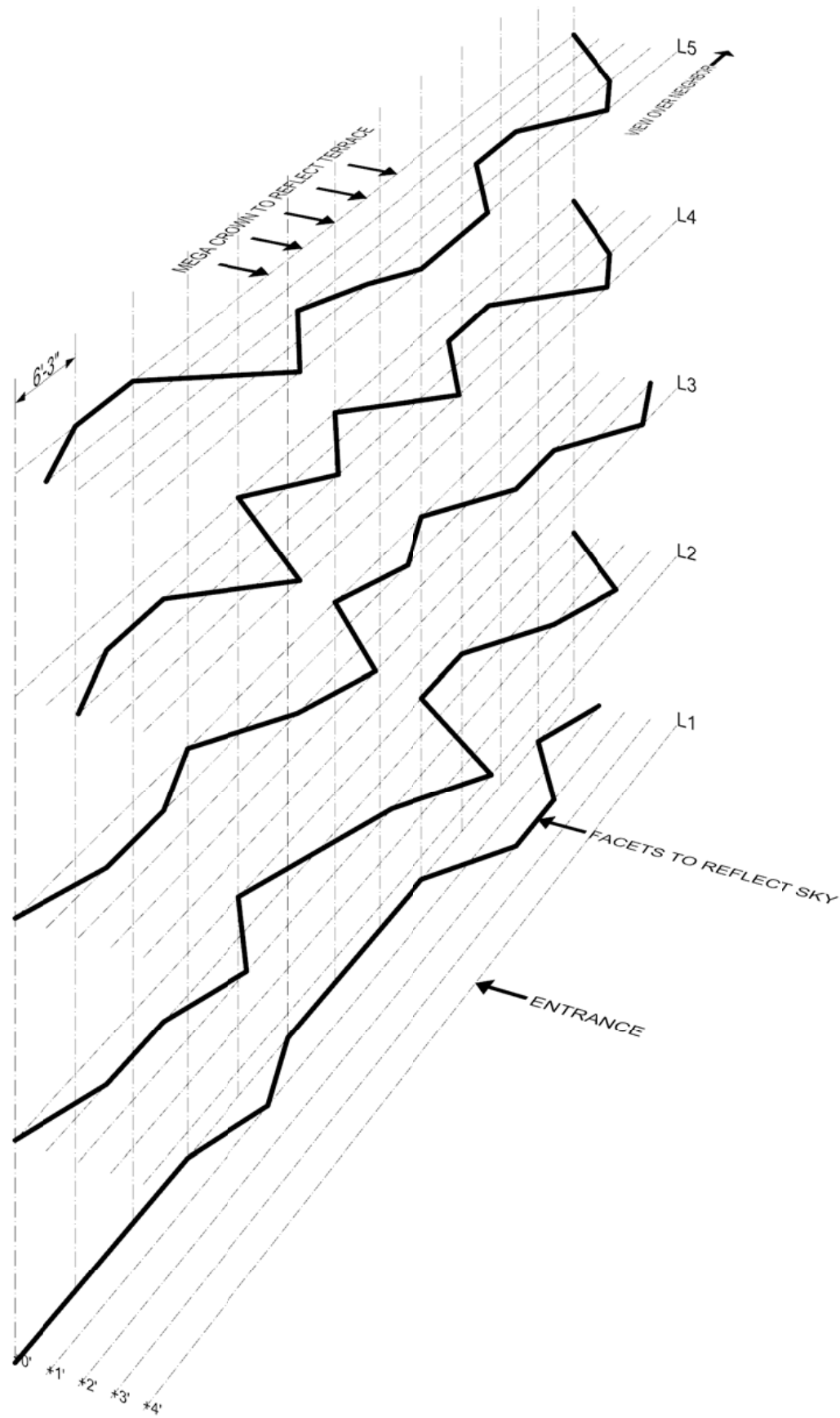

827-831 BROADWAY · FACETED FACADE GEOMETRY MAPPING

**SCALE** As Noted  
**CLIENT** Quality Capital  
**PROJECT NUMBER** 17.32  
**DATE** November 06 2017





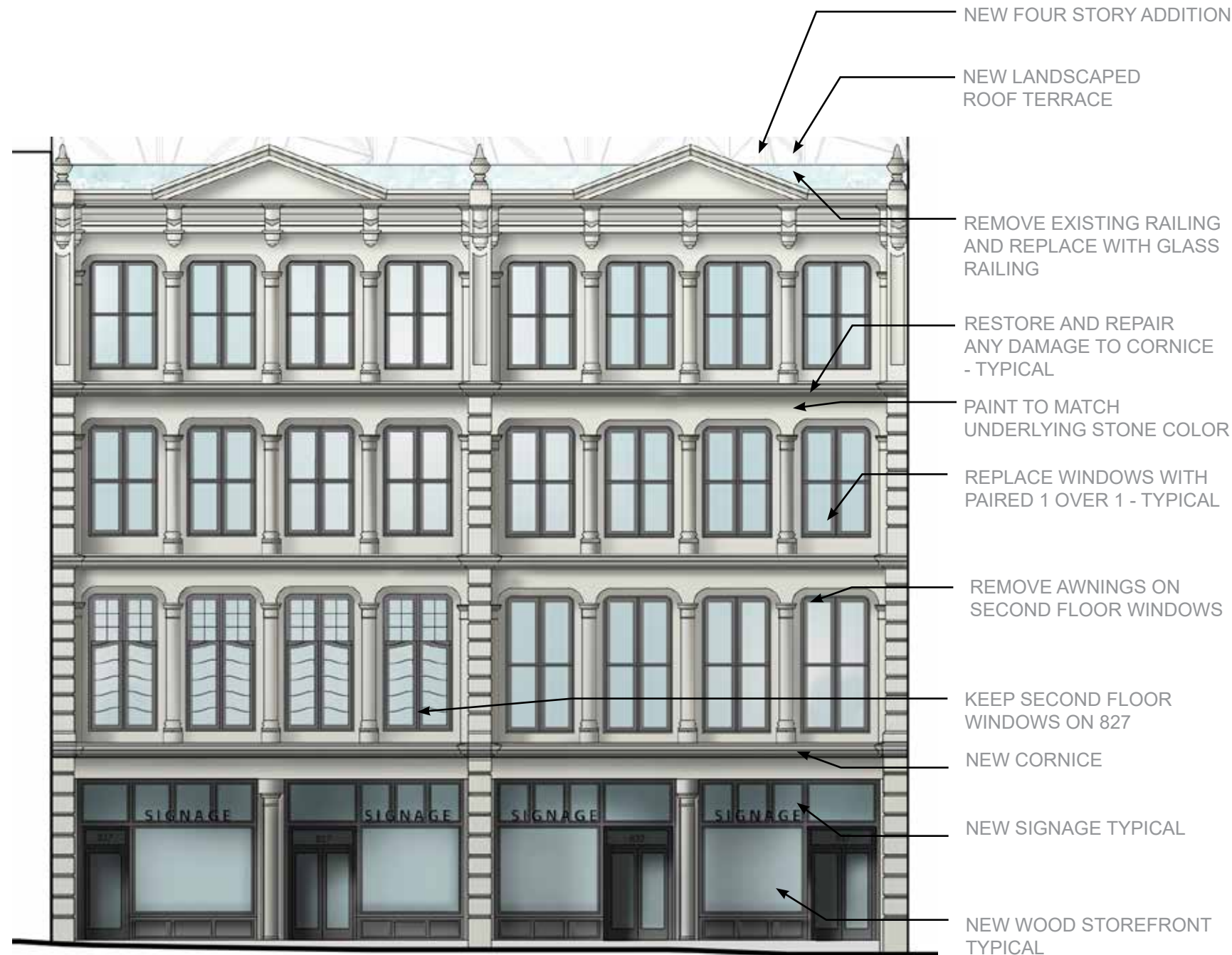

BROADWAY - EXISTING AND PROPOSED ELEVATIONS

827-831 BROADWAY · RESTORATION WORK

SCALE As Noted  
 CLIENT Quality Capital  
 PROJECT NUMBER 17.32  
 DATE November 06 2017



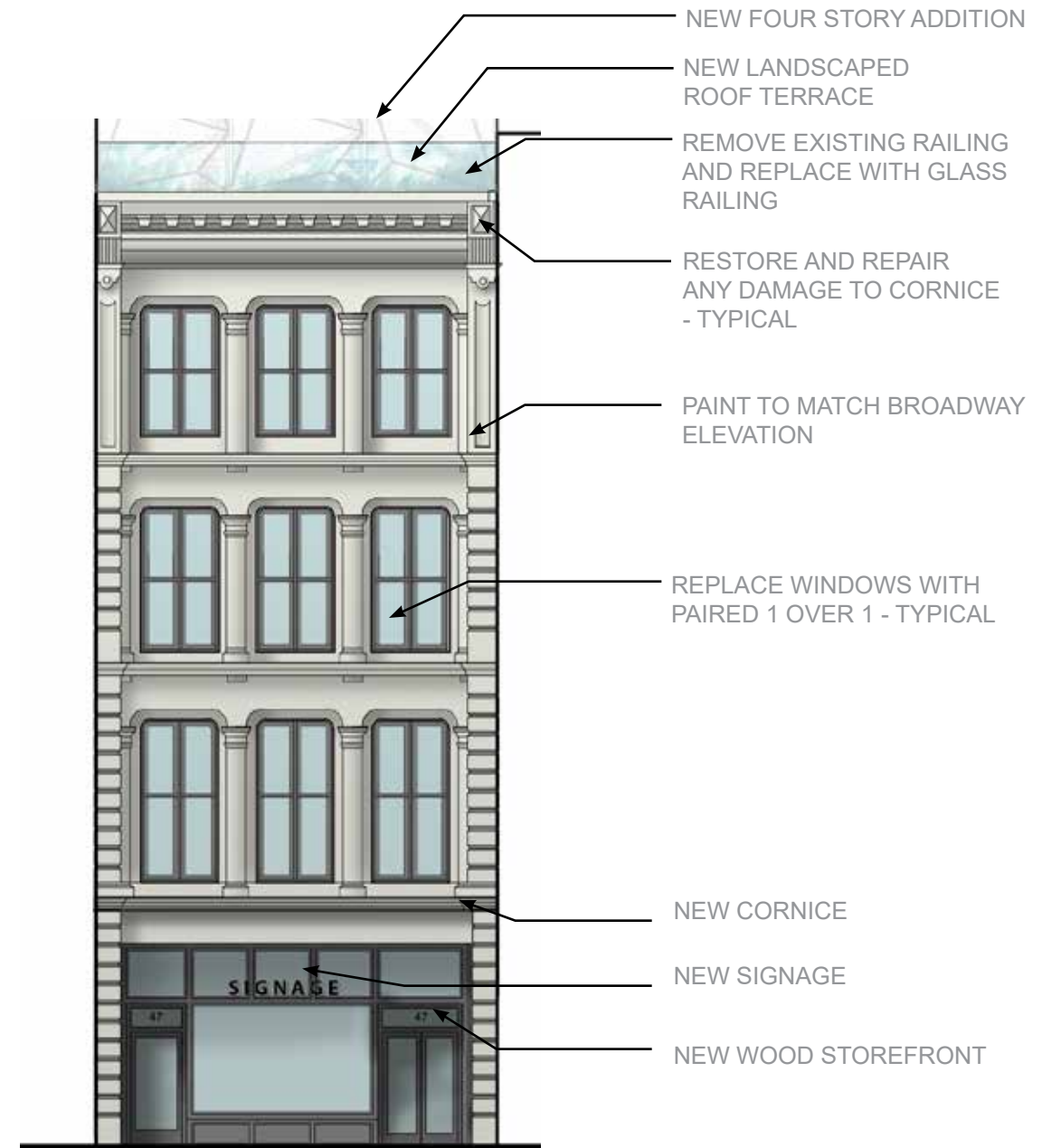

12TH STREET - EXISTING AND PROPOSED ELEVATIONS  
(NOT DESIGNATED) · RESTORATION WORK



**DXA studio**  
894 6th Avenue  
5th Floor  
NYC 10001  
T 212 874 0567  
dxastudio.com

**SCALE** As Noted  
**CLIENT** Quality Capital  
**PROJECT NUMBER** 17.32  
**DATE** November 06 2017



BROADWAY - EXISTING AND PROPOSED ELEVATIONS  
 827-831 BROADWAY · RENDERED STOREFRONT ELEVATIONS

SCALE As Noted  
 CLIENT Quality Capital  
 PROJECT NUMBER 17.32  
 DATE November 06 2017



**DXA studio**  
 894 6th Avenue  
 5th Floor  
 NYC 10001  
 T 212 874 0567  
 dxastudio.com



12TH STREET - EXISTING AND PROPOSED ELEVATIONS  
 (NOT DESIGNATED) · RENDERED STOREFRONT ELEVATIONS

SCALE As Noted  
 CLIENT Quality Capital  
 PROJECT NUMBER 17.32  
 DATE November 06 2017



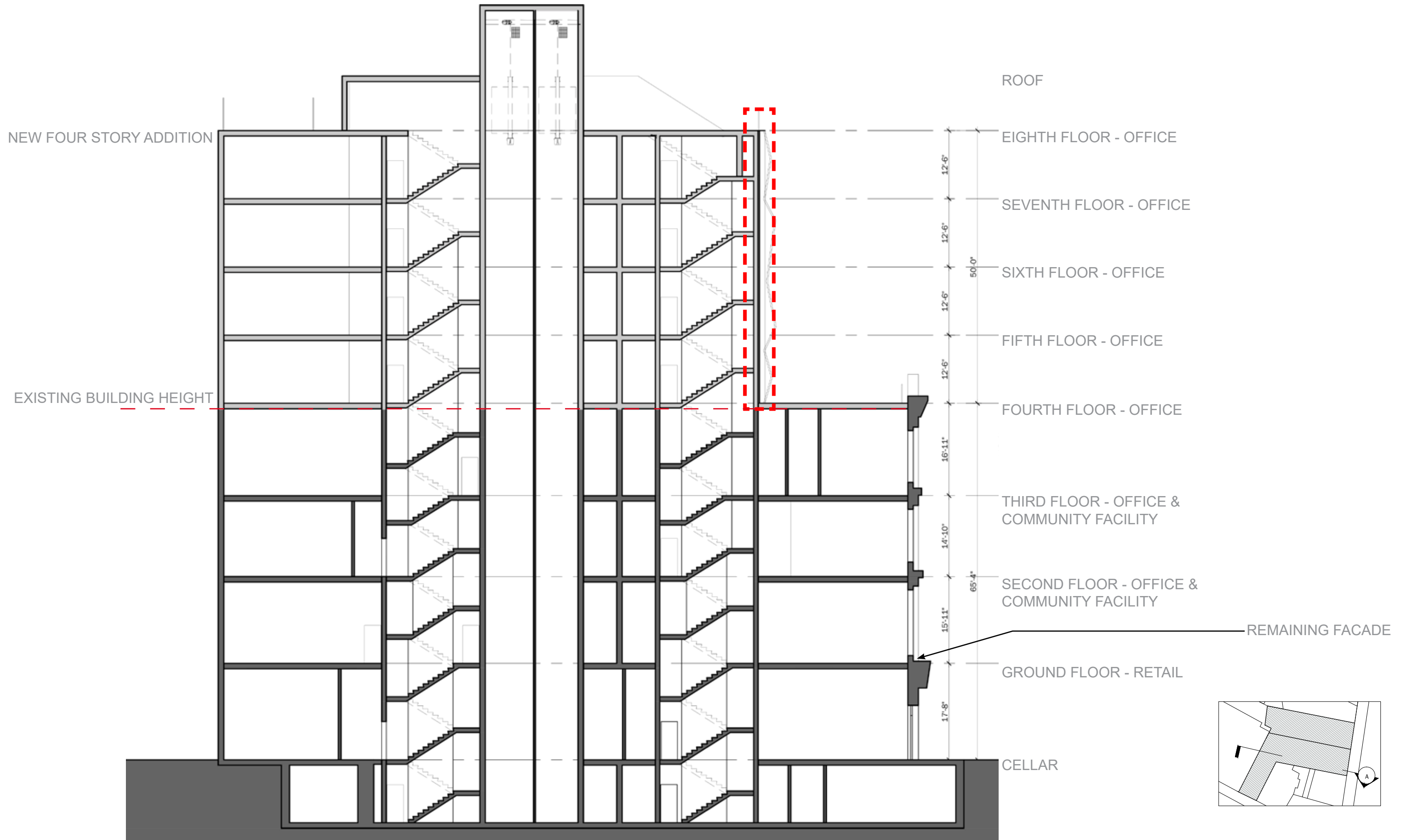

827-831 BROADWAY · PROPOSED SECTION

SCALE As Noted  
 CLIENT Quality Capital  
 PROJECT NUMBER 17.32  
 DATE November 06 2017

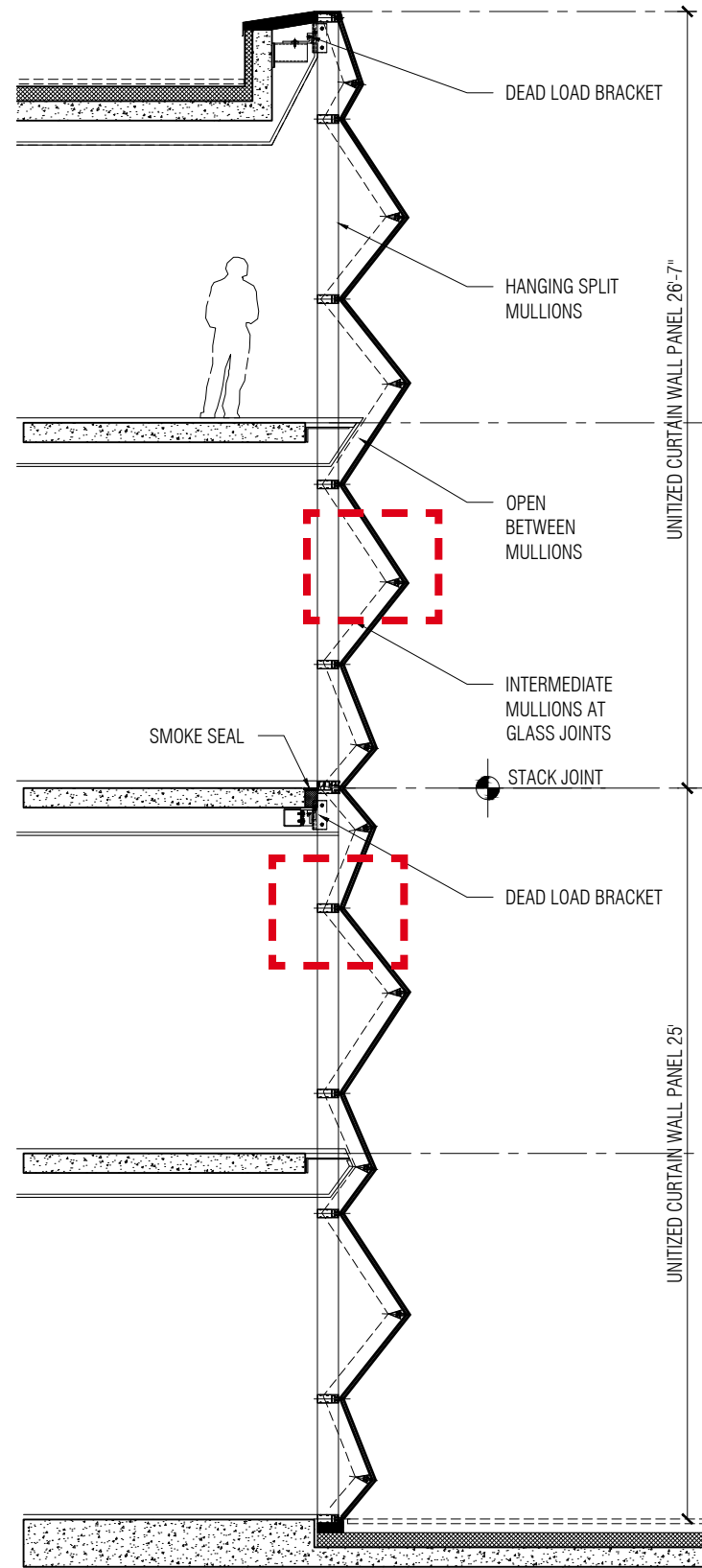

BROADWAY FACADE DETAIL SECTION

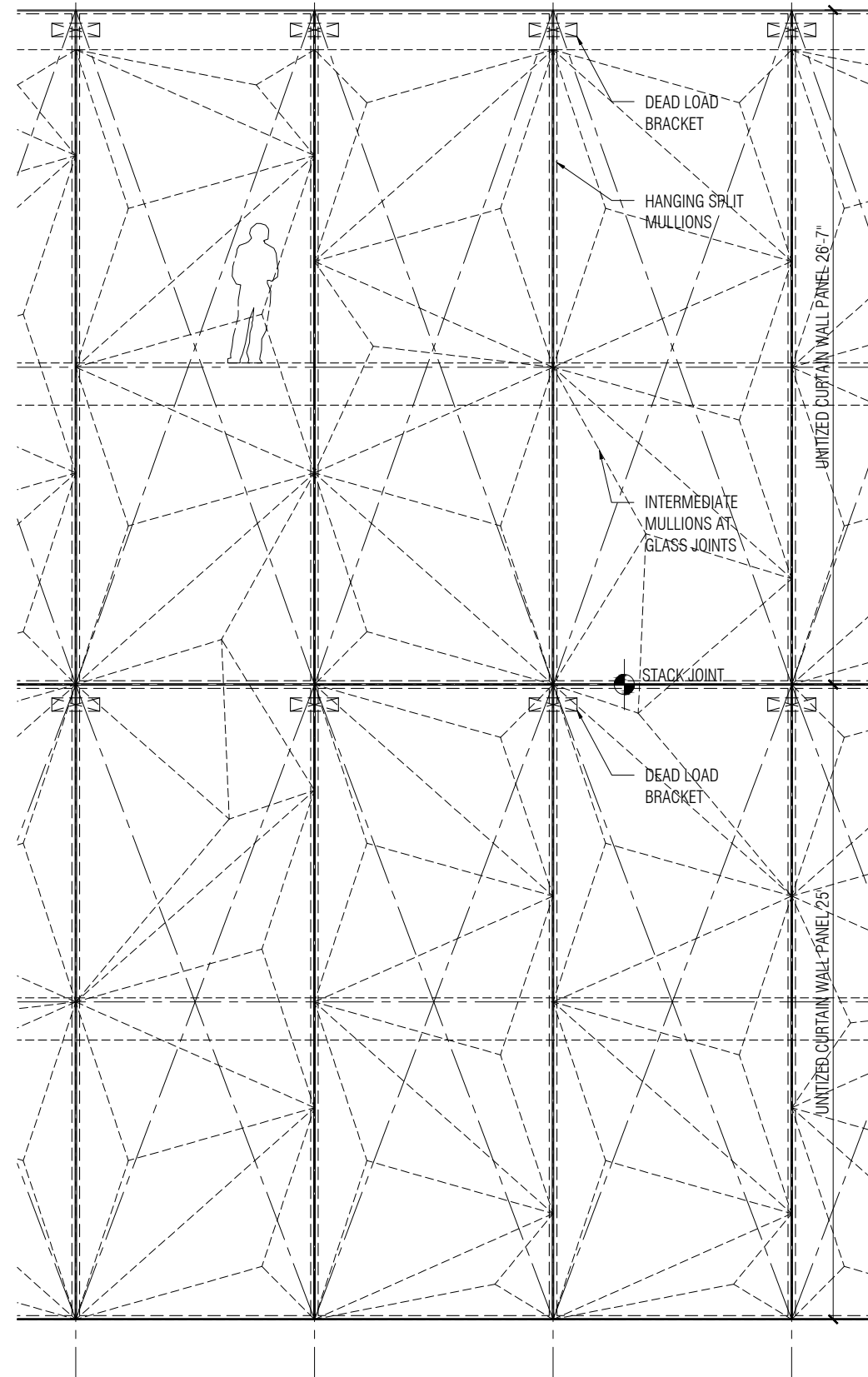

BROADWAY FACADE DETAIL ELEVATION

827-831 BROADWAY · FACADE DESIGN - PRELIMINARY FACADE DETAIL SECTION



**DXA studio**  
 894 6th Avenue  
 5th Floor  
 NYC 10001  
 T 212 874 0567  
 dxastudio.com

**SCALE** As Noted  
**CLIENT** Quality Capital  
**PROJECT NUMBER** 17.32  
**DATE** November 06 2017

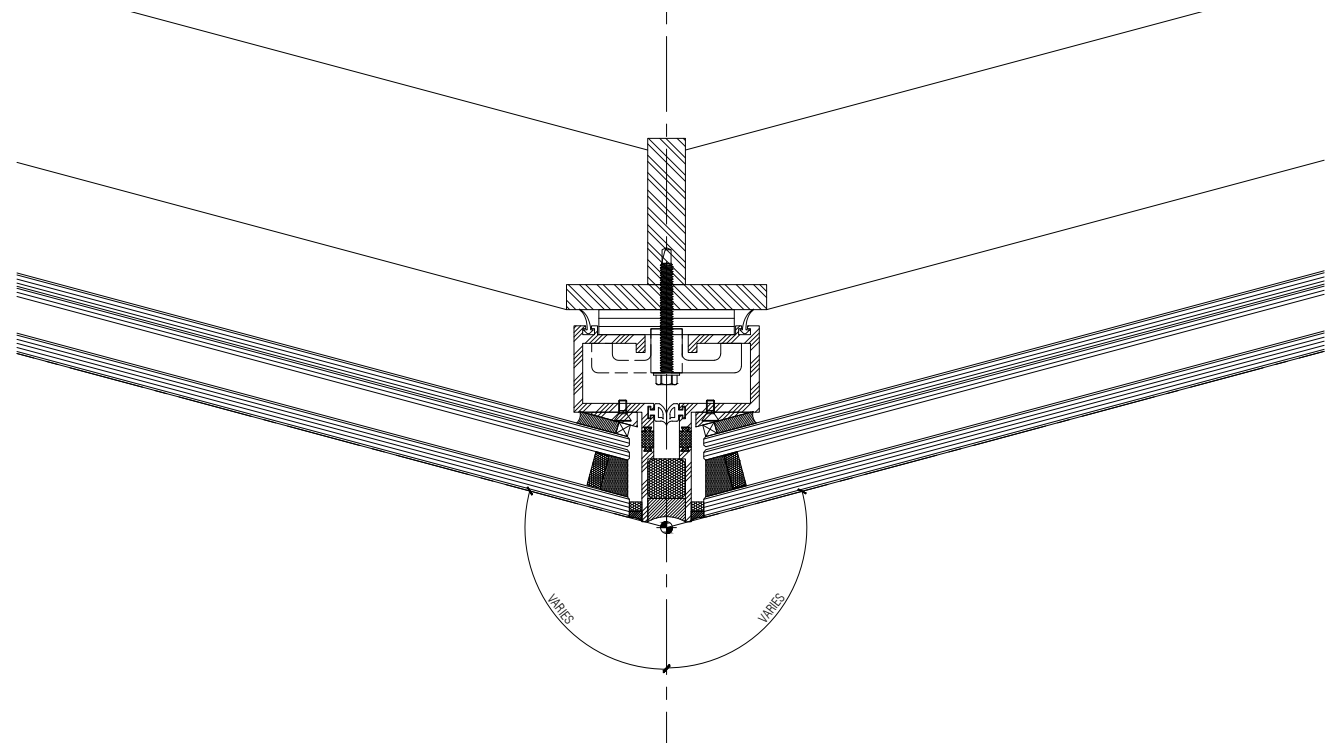

TYPICAL FACETED DETAIL - CONCAVE GLAZING

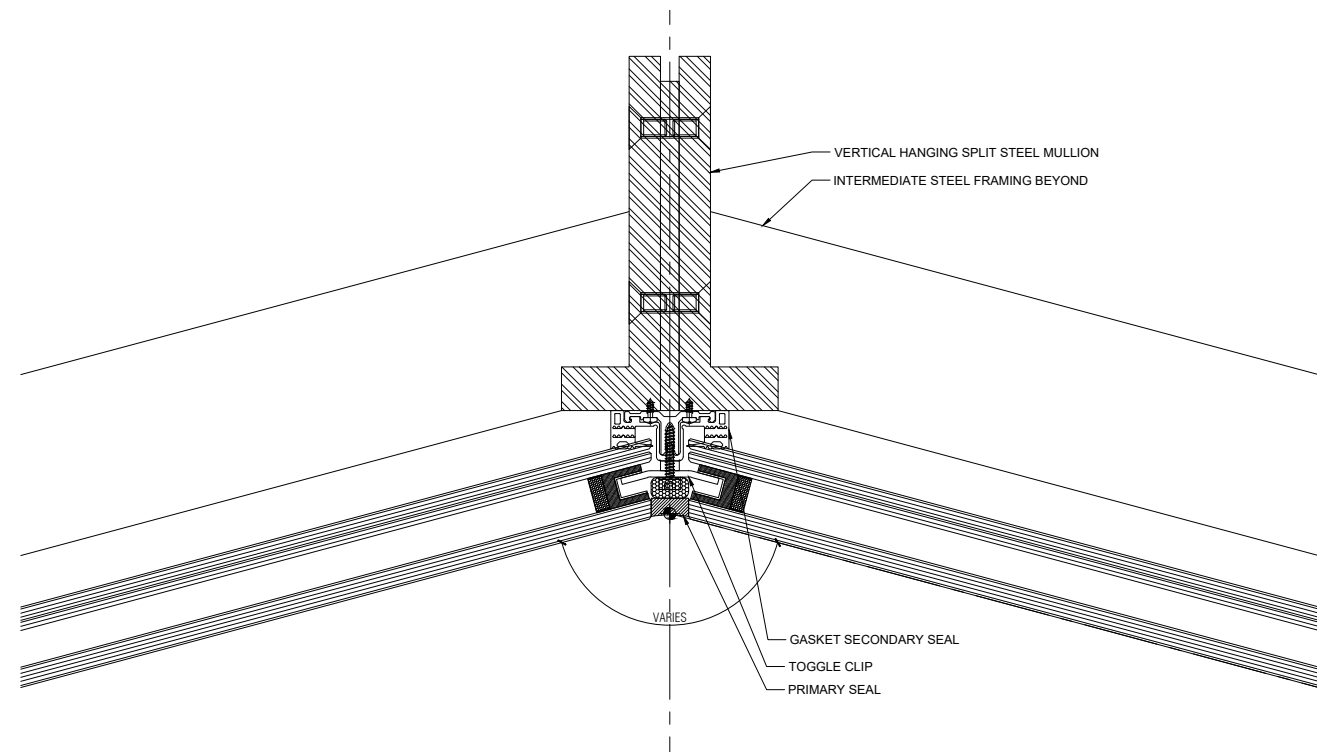

TYPICAL FACETED DETAIL - CONVEX GLAZING



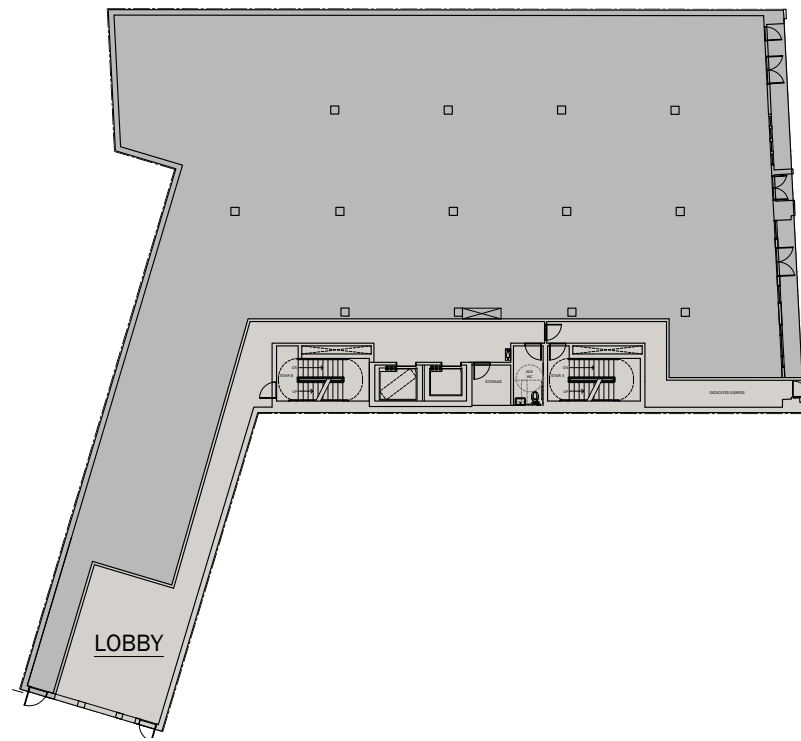

GROUND FLOOR PLAN

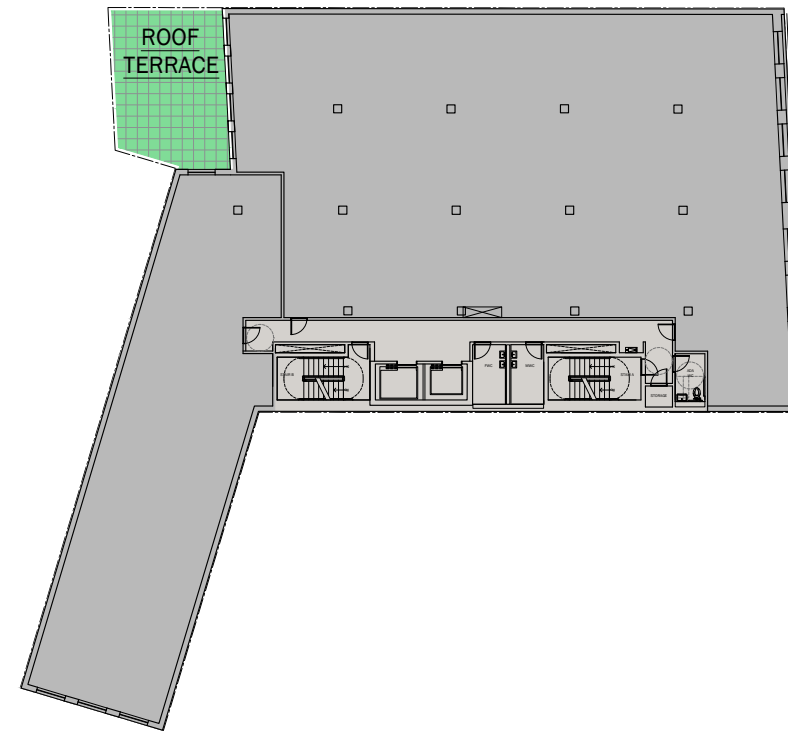

2ND - 4TH FLOOR PLANS

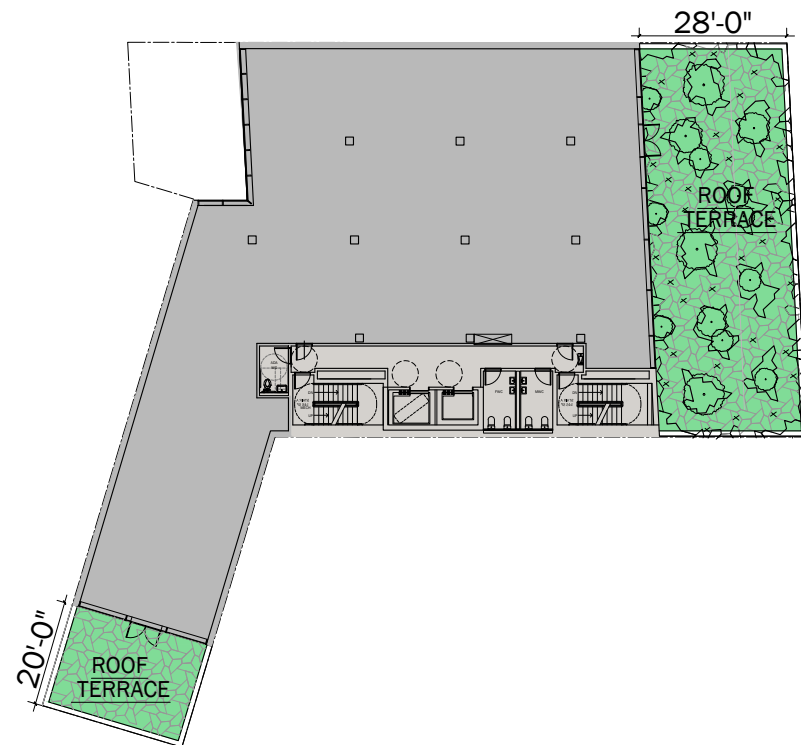

5TH - 8TH FLOOR PLANS

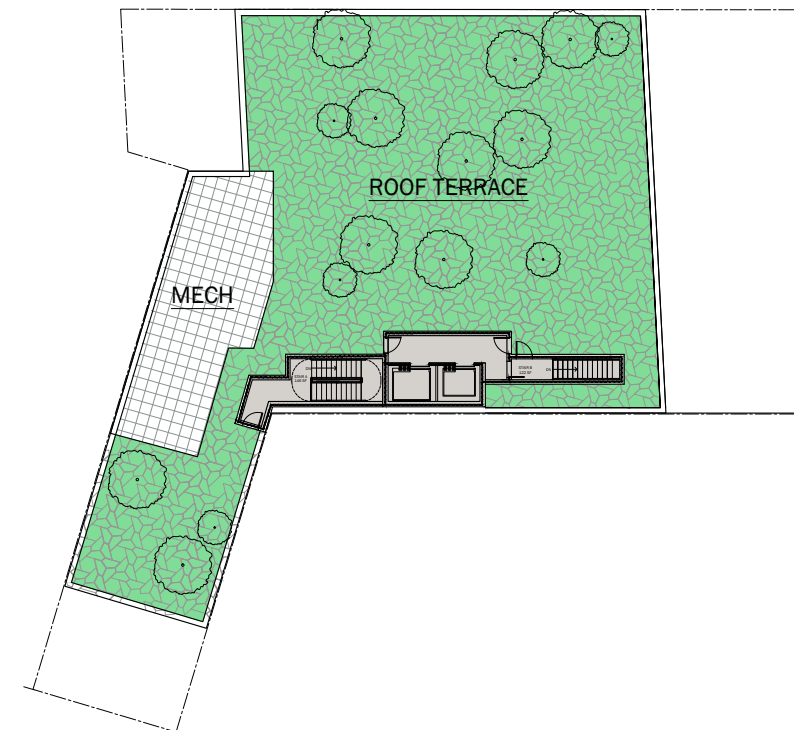

ROOF

827-831 BROADWAY - PROPOSED LAYOUTS

SCALE As Noted  
 CLIENT Quality Capital  
 PROJECT NUMBER 17.32  
 DATE November 06 2017

**FOR ILLUSTRATIVE PURPOSES ONLY**





**NW**

**LANDSCAPE  
DESIGN**



**DXA studio**

dxastudio.com

894 6th Avenue  
5th Floor  
NYC 10001  
T 212 874 0567

**827-831 BROADWAY - LANDSCAPE DESIGN - LANDSCAPE PRECEDENTS**

**SCALE** As Noted  
**CLIENT** Quality Capital  
**PROJECT NUMBER** 17.32  
**DATE** November 06 2017

**42**

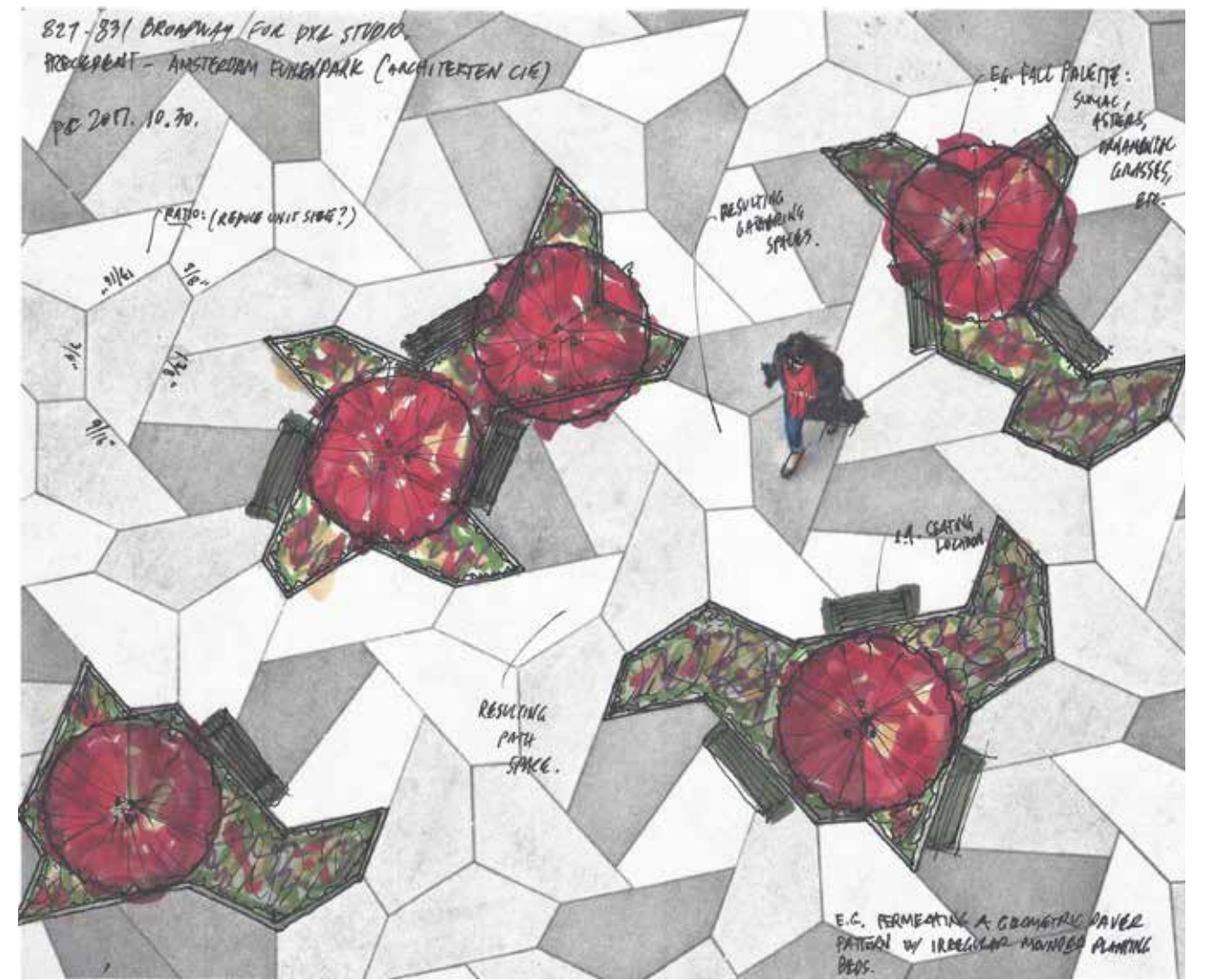
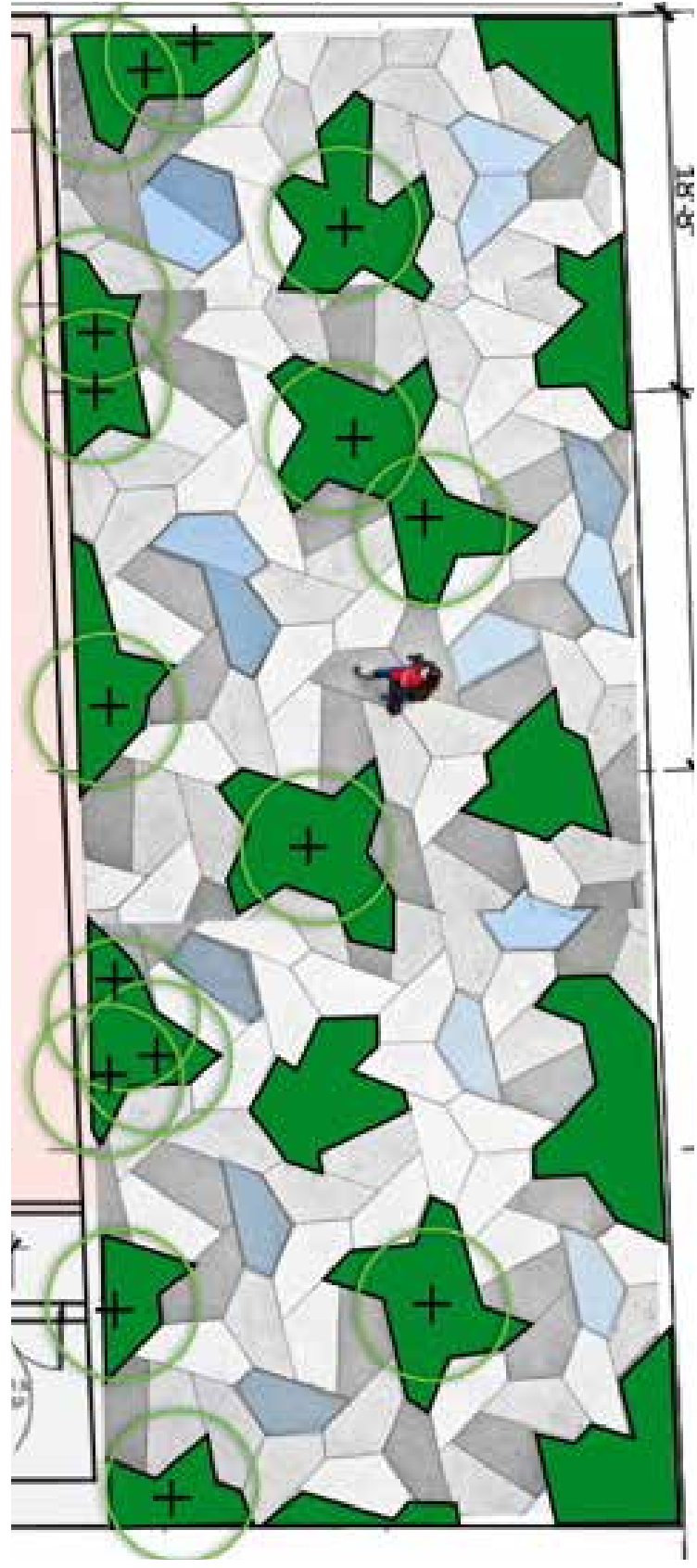
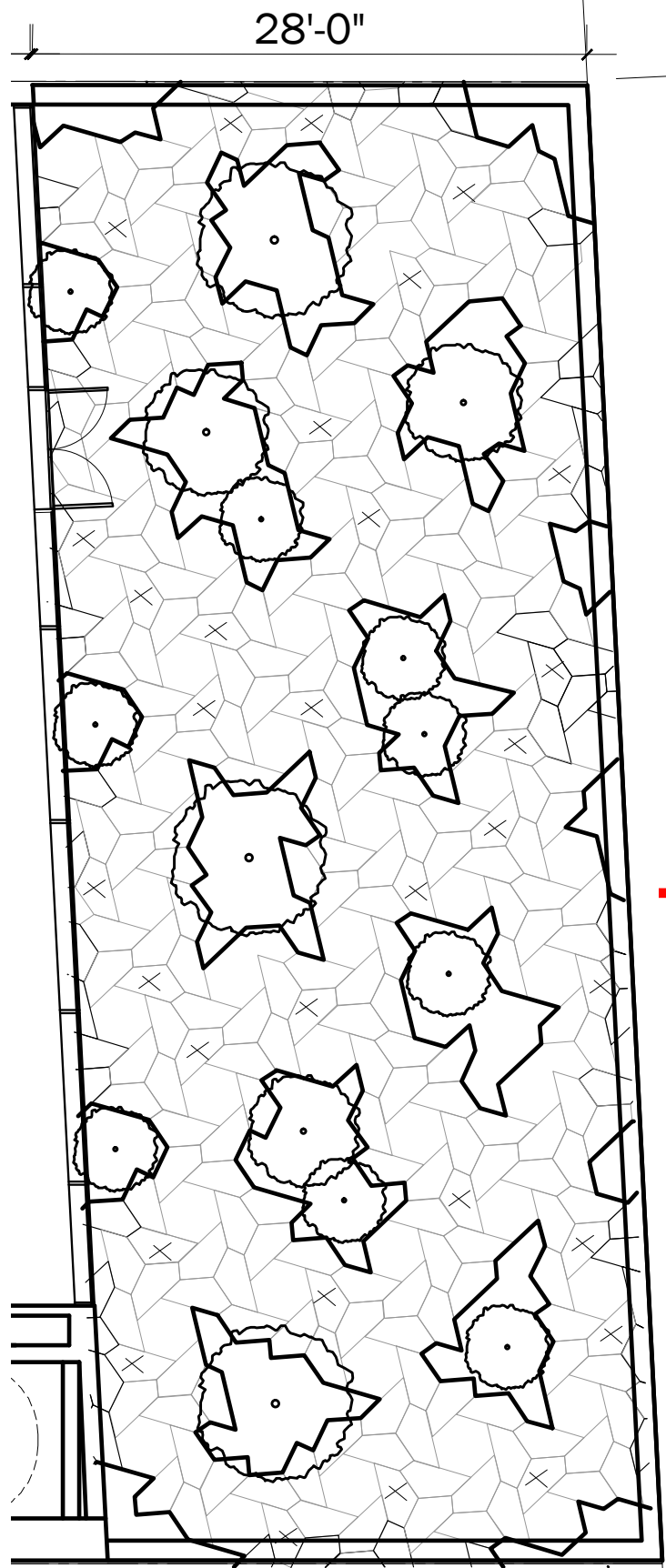

TERRACE ROOF - LANDSCAPE LAYOUT

ADD VEGETATION & SKYLIGHTS

MOUNDED PLANTING BED DETAILS

GEOMETRIC PATTERN WITH MOULDED PLANTING AREAS



**DXA studio**  
 894 6th Avenue  
 5th Floor  
 NYC 10001  
 T 212 874 0567  
 dxastudio.com

**827-831 BROADWAY - LANDSCAPE DESIGN**  
 SCALE As Noted  
 CLIENT Quality Capital  
 PROJECT NUMBER 17.32  
 DATE November 06 2017

**827-831 BROADWAY**

DXA studio