

DXA studio  
827- 831 Broadway  
April 24th, 2018

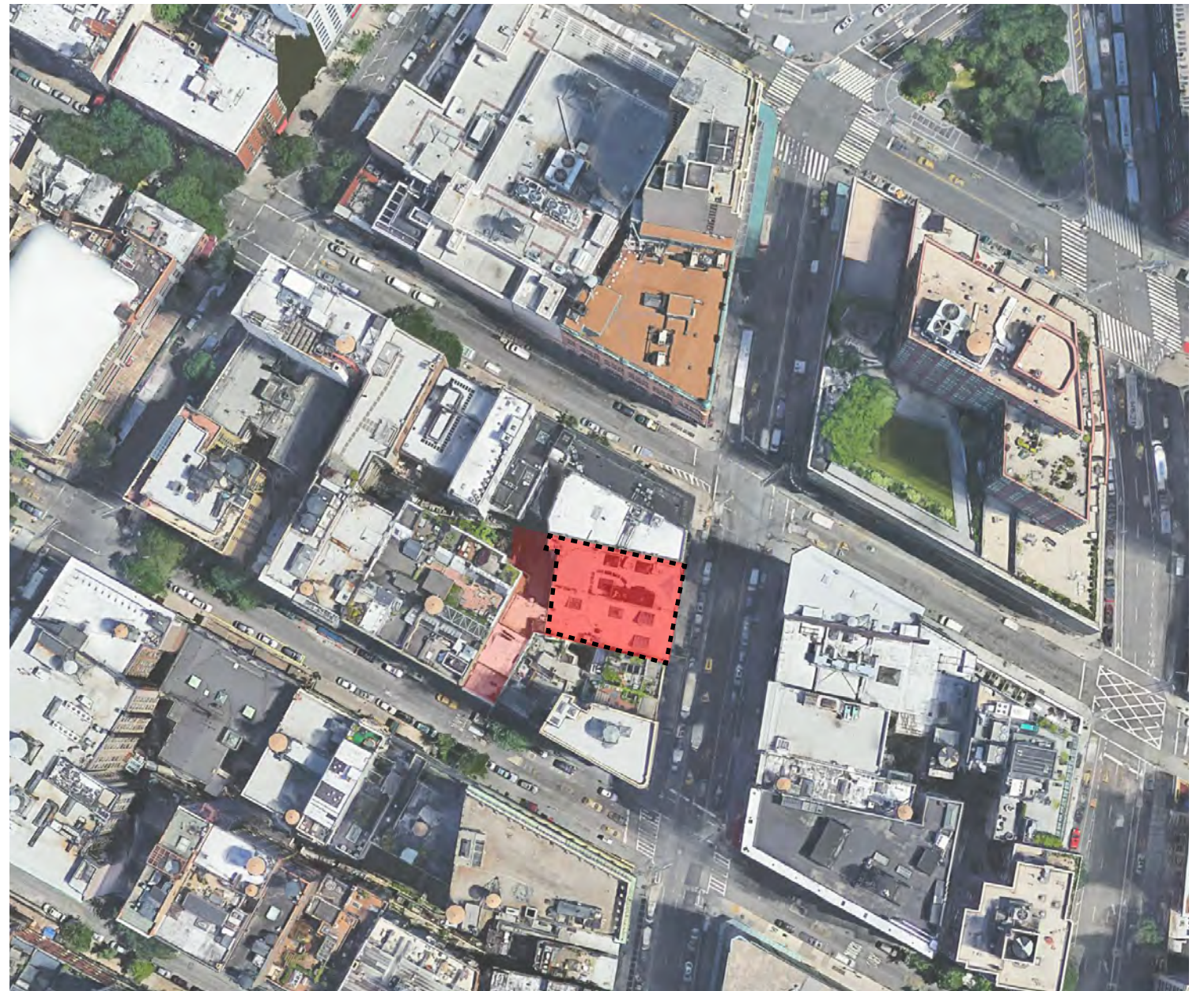



**STREET VIEW**



**SATELLITE VIEW OF SITE**

**PROJECT GOALS**

- CELEBRATE THE ARTISTS OF THE ABSTRACT EXPRESSIONIST MOVEMENT THAT THRUST NEW YORK TO THE WORLD STAGE, UNSEATING PARIS AS THE CENTER OF THE ART WORLD. RAISE AWARENESS AS TO THE CULTURAL SIGNIFICANCE OF WILLEM AND ELAINE DE KOONING, LARRY POONS, PAUL JENKINS, JULES OLITSKI AND HERBERT FERBER, OF THEIR WORK AND TENURE IN THE BUILDING.
- RESTORE THE EXISTING BUILDING TO ITS PERIOD OF SIGNIFICANCE WHILE RESPECTING THE ORIGINAL DESIGN.

**827-831 BROADWAY · SITE CONTEXT**

**SCALE** As Noted  
**CLIENT** BH Quality Broadway Investors  
**PROJECT NUMBER** 17.32  
**DATE** April 24th 2018



**DXA studio** 894 6th Avenue  
 5th Floor  
 NYC 10001  
 T 212 874 0567  
 dxastudio.com



# **SITE ANALYSIS & EXISTING CONDITIONS**

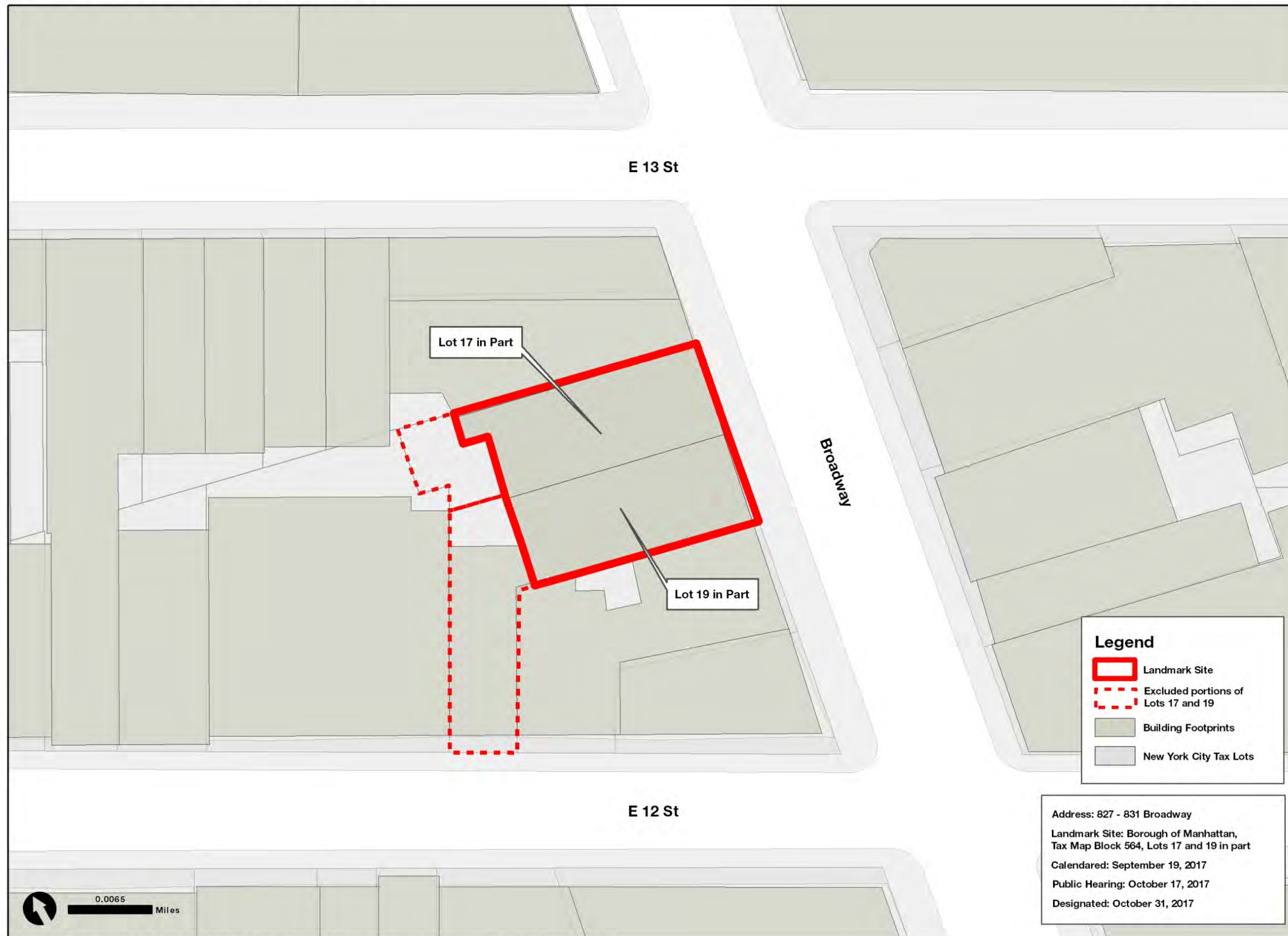

Graphic Source: MapPLUTO, Edition 16v2, Author: New York City Landmarks Preservation Commission, SRM, Date: 10.27.2017

827-831 BROADWAY · SITE DESIGNATION

SCALE	As Noted
CLIENT	BH Quality Broadway Investors
PROJECT NUMBER	17.32
DATE	April 24th 2018





BROADWAY - 1899 (NYPL)



821-835 BROADWAY - 1910

827-831 BROADWAY · HISTORIC PHOTOS

SCALE As Noted  
 CLIENT BH Quality Broadway Investors  
 PROJECT NUMBER 17.32  
 DATE April 24th 2018





TAX PHOTOS BUILDING - 827 & 831 CIRCA 1940



TAX PHOTOS BUILDING - 827 & 831 CIRCA 1980



**DXA studio**

894 6th Avenue  
5th Floor  
NYC 10001  
T 212 874 0567

dxastudio.com

827-831 BROADWAY · HISTORIC TAX PHOTOS

SCALE As Noted  
CLIENT BH Quality Broadway Investors  
PROJECT NUMBER 17.32  
DATE April 24th 2018



**BROADWAY FACADE & STOREFRONT**

**827-831 BROADWAY · PHOTOS OF EXISTING FACADES**

**SCALE** As Noted  
**CLIENT** BH Quality Broadway Investors  
**PROJECT NUMBER** 17.32  
**DATE** April 24th 2018





EAST 12TH STREET FACADE & STOREFRONT

(NOT DESIGNATED) · PHOTOS OF EXISTING FACADES

<b>SCALE</b>	As Noted
<b>CLIENT</b>	BH Quality Broadway Investors
<b>PROJECT NUMBER</b>	17.32
<b>DATE</b>	April 24th 2018



**DXA studio**  
 894 6th Avenue  
 5th Floor  
 NYC 10001  
 T 212 874 0567  
 dxastudio.com





BROADWAY ELEVATION PHOTOMONTAGE



**DXA studio**  
 894 6th Avenue  
 5th Floor  
 NYC 10001  
 T 212 874 0567  
 dxastudio.com

827-831 BROADWAY · SURROUNDING BUILDINGS

**SCALE** As Noted  
**CLIENT** BH Quality Broadway Investors  
**PROJECT NUMBER** 17.32  
**DATE** April 24th 2018



# **HISTORY & INSPIRATION**

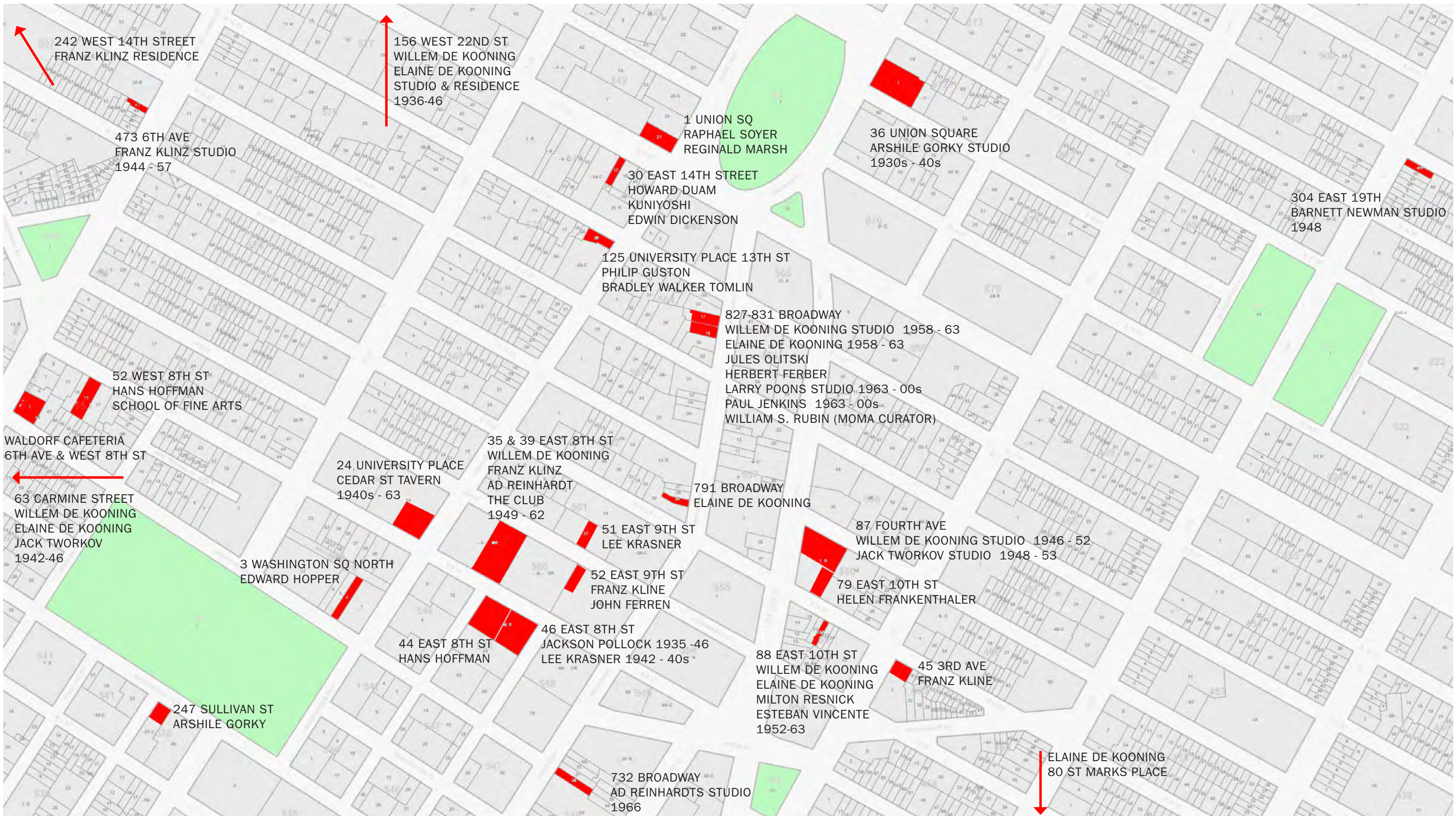

827-831 BROADWAY · HISTORY & INSPIRATION - THE NEW YORK SCHOOL - ABSTRACT EXPRESSIONIST STUDIOS AND HANGOUTS - MID 20TH CENTURY



**DXA studio**  
894 6th Avenue  
5th Floor  
NYC 10001  
T 212 874 0567  
dxastudio.com

**SCALE** As Noted  
**CLIENT** BH Quality Broadway Investors  
**PROJECT NUMBER** 17.32  
**DATE** April 24th 2018

**PROMINENT ARTISTS OF  
THE NEW YORK SCHOOL**



JACKSON POLLOCK



MARK ROTHKO

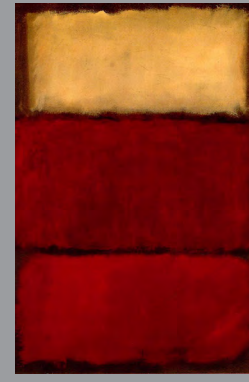

FRANZ KLINE



ARSHILE GORKY



ADOLF GOTTLIEB



HELEN FRANKENTHALER

**827-831 BROADWAY  
CONTRIBUTING ARTISTS**



LARRY POONS



PAUL JENKINS

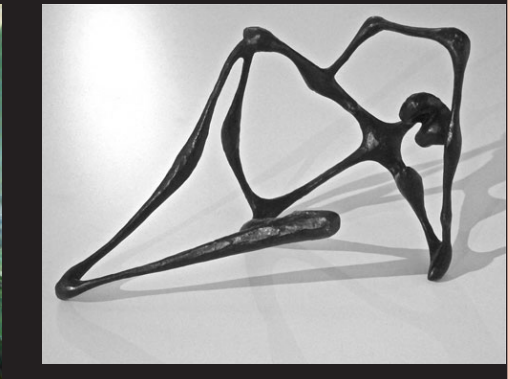

HERBERT FERBER



WILLEM DE KOONING

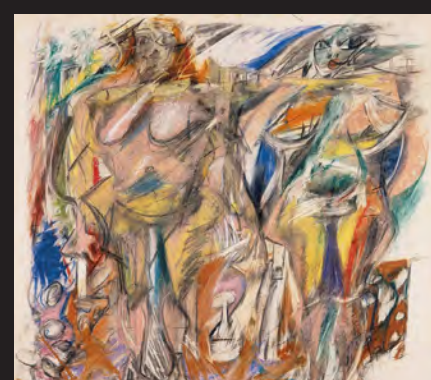
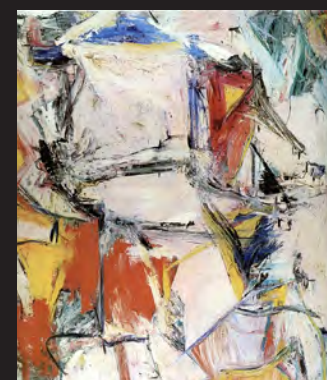

ELAINE DE KOONING

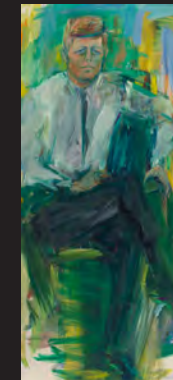
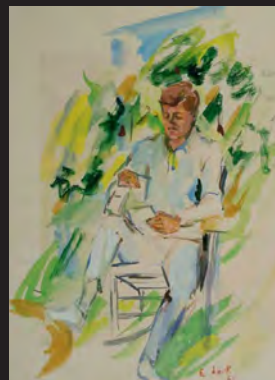

JULES OLITSKI

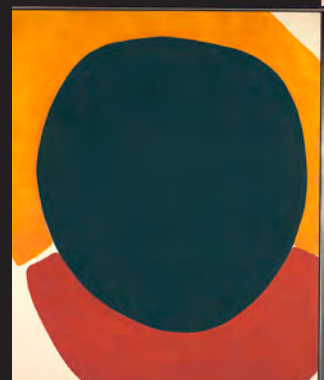

**827-831 BROADWAY · HISTORY & INSPIRATION: ABSTRACT EXPRESSIONISM**



**DXA studio**  
894 6th Avenue  
5th Floor  
NYC 10001  
T 212 874 0567  
dxastudio.com

**SCALE** As Noted  
**CLIENT** BH Quality Broadway Investors  
**PROJECT NUMBER** 17.32  
**DATE** April 24th 2018

WILLEM DE KOONING IN  
BROADWAY STUDIO 1958 - 1963

**BLACK & WHITE  
ABSTRACT  
- LATE 1940s**



**FIGURATIVE  
REPRESENTATION  
- EARLY 1950s**

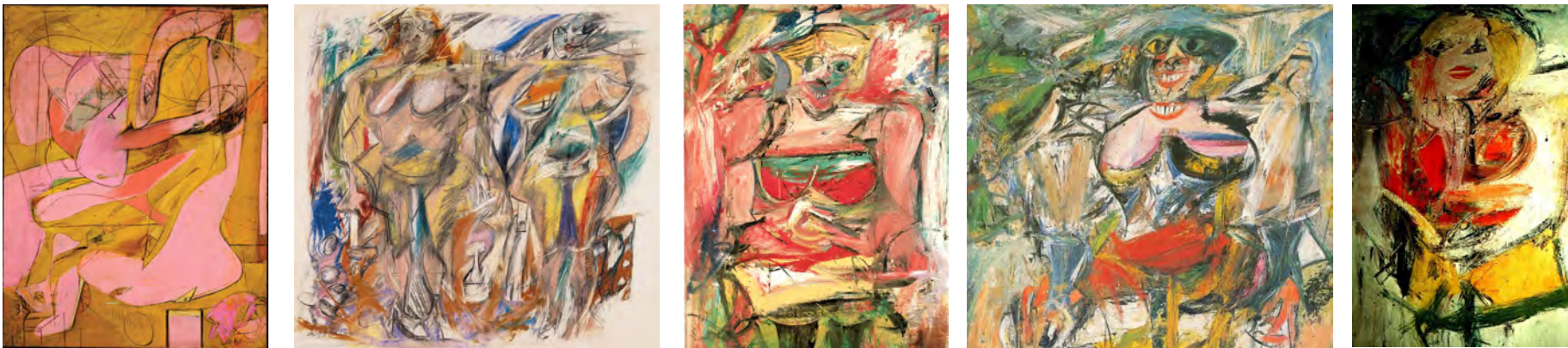

**URBAN LANDSCAPE  
REPRESENTATION  
- LATE 1950s**



**RURAL LANDSCAPE  
REPRESENTATION  
- EARLY 1960s**



**PAINTINGS WILLEM DE KOONING  
PRODUCED IN 831 BROADWAY  
- ROSY - FINGERED DAWN AT LOUSE POINT  
- DOOR TO THE RIVER**

**DE KOONING AS A MICROCOSM OF THE MOVEMENT**

**827-831 BROADWAY · HISTORY & INSPIRATION - DE KOONING**



**DXA studio** 894 6th Avenue  
5th Floor  
NYC 10001  
T 212 874 0567  
dxastudio.com

**SCALE** As Noted  
**CLIENT** BH Quality Broadway Investors  
**PROJECT NUMBER** 17.32  
**DATE** April 24th 2018

GOTHAM NEWS

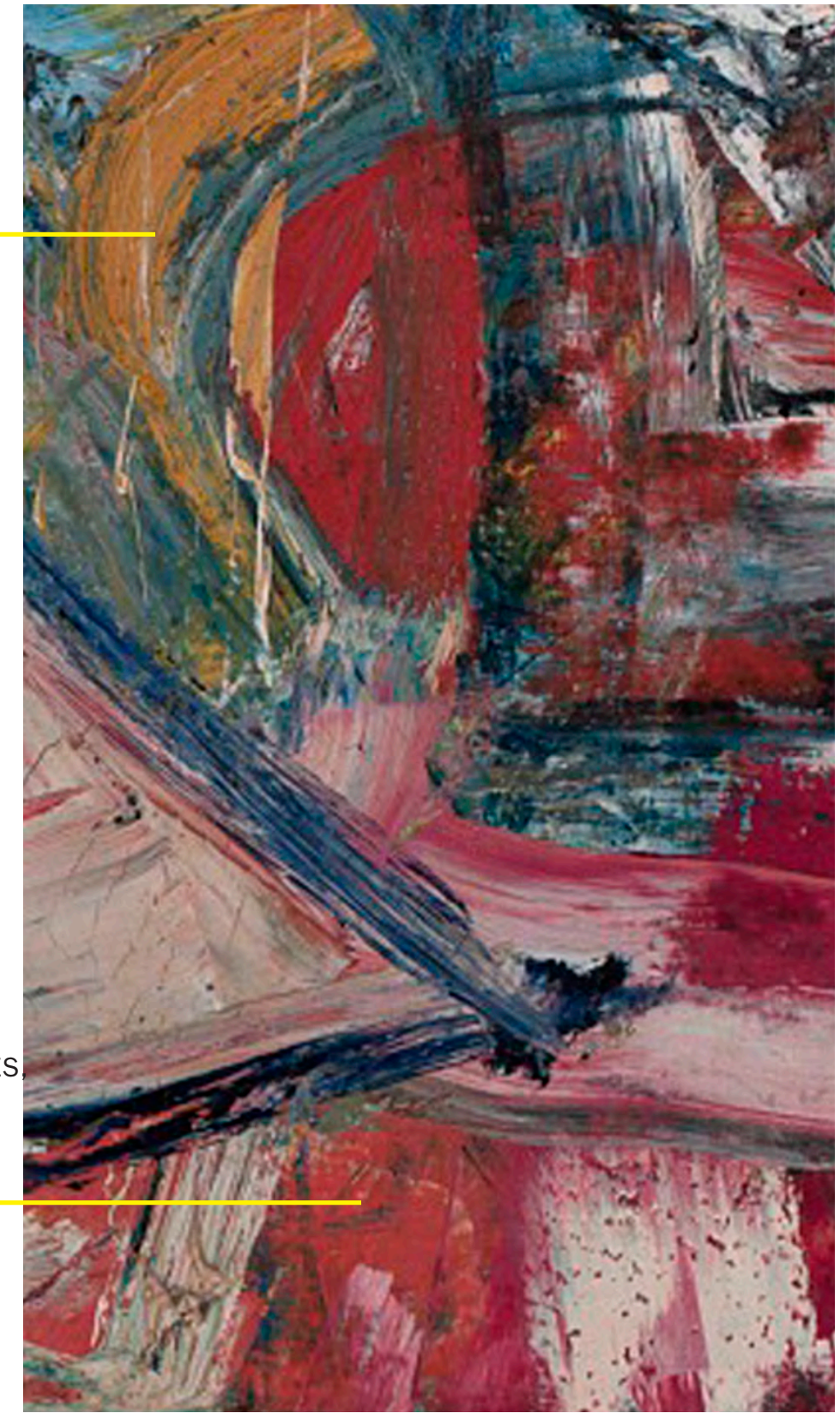
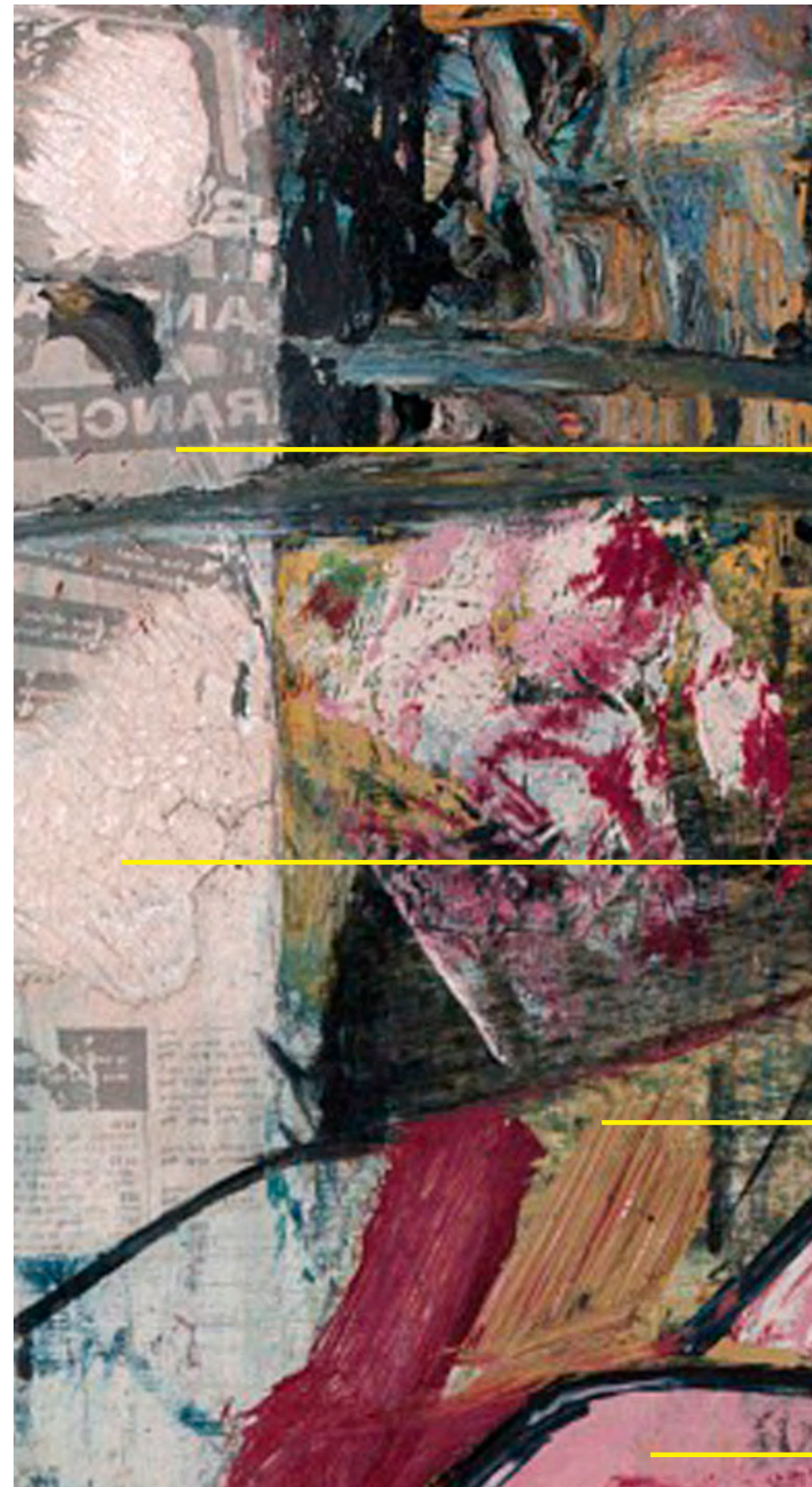
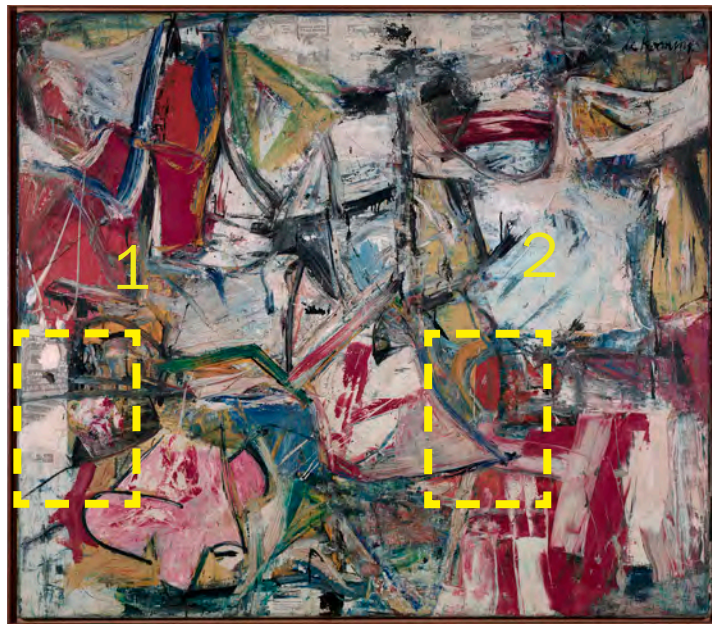

GESTURAL STROKES

NEWSPAPER CLIPPINGS

IMPASTO PAINTING TECHNIQUES

THICK BRUSH STROKES SHARP GEOMETRY

TRANSPARENCY & OPACITY

FIGURATIVE REPRESENTATION

PAINTING AS CONSTRUCTION: WILLEM DE KOONING - GOTHAM NEWS DETAILS

827-831 BROADWAY · HISTORY & INSPIRATION - DE KOONING



**DXA studio**

894 6th Avenue  
5th Floor  
NYC 10001  
T 212 874 0567

dxastudio.com

SCALE  
CLIENT  
PROJECT NUMBER  
DATE

As Noted  
BH Quality Broadway Investors  
17.32  
April 24th 2018

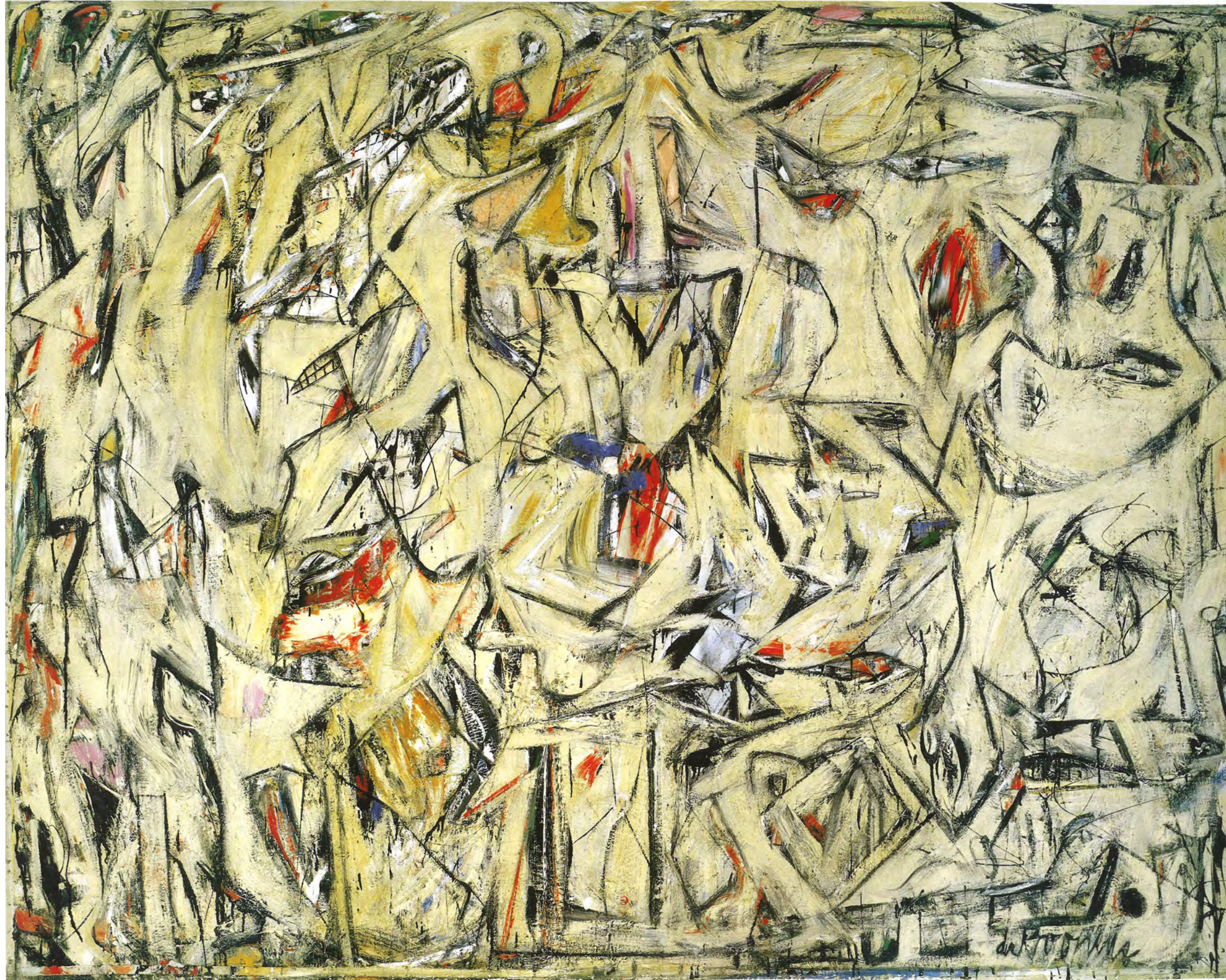

**PAINTING AS CONSTRUCTION: WILLEM DE KOONING - EXCAVATION**  
**827-831 BROADWAY · HISTORY & INSPIRATION - DE KOONING**

<b>SCALE</b>	As Noted
<b>CLIENT</b>	BH Quality Broadway Investors
<b>PROJECT NUMBER</b>	17.32
<b>DATE</b>	April 24th 2018



**DXA studio**

dxastudio.com

894 6th Avenue  
5th Floor  
NYC 10001  
T 212 874 0567



KUNSTHAUS BREGENZ, VORARLBERG, AUSTRIA - PETER ZUMTHOR  
 - LAYERING, DEPTH & MOTION



MIRROR HOUSE, - REMCO SIEBRING  
 - REFLECTION & TRANSPARENCY



CASTLE DOWNS PAVILION, EDMONTON, CANADA - GH3  
 - FOLDING & DISTORTION



LABAN DANCE CENTER, LONDON - HERZOG AND DE MEURON  
 - BLURRING & BLENDING

827-831 BROADWAY · ARCHITECTURAL PRECEDENTS: ANALOGOUS TO PAINTING TECHNIQUES



**DXA studio** 894 6th Avenue  
 5th Floor  
 NYC 10001  
 T 212 874 0567  
 dxastudio.com

**SCALE** As Noted  
**CLIENT** BH Quality Broadway Investors  
**PROJECT NUMBER** 17.32  
**DATE** April 24th 2018

**16**





# **FACADE DESIGN**



827-831 BROADWAY - VISUALIZATION - BROADWAY FACADE



**DXA studio**

894 6th Avenue  
5th Floor  
NYC 10001  
T 212 874 0567

[dxastudio.com](http://dxastudio.com)

<b>SCALE</b>	As Noted
<b>CLIENT</b>	BH Quality Broadway Investors
<b>PROJECT NUMBER</b>	17.32
<b>DATE</b>	April 24th 2018

**18**

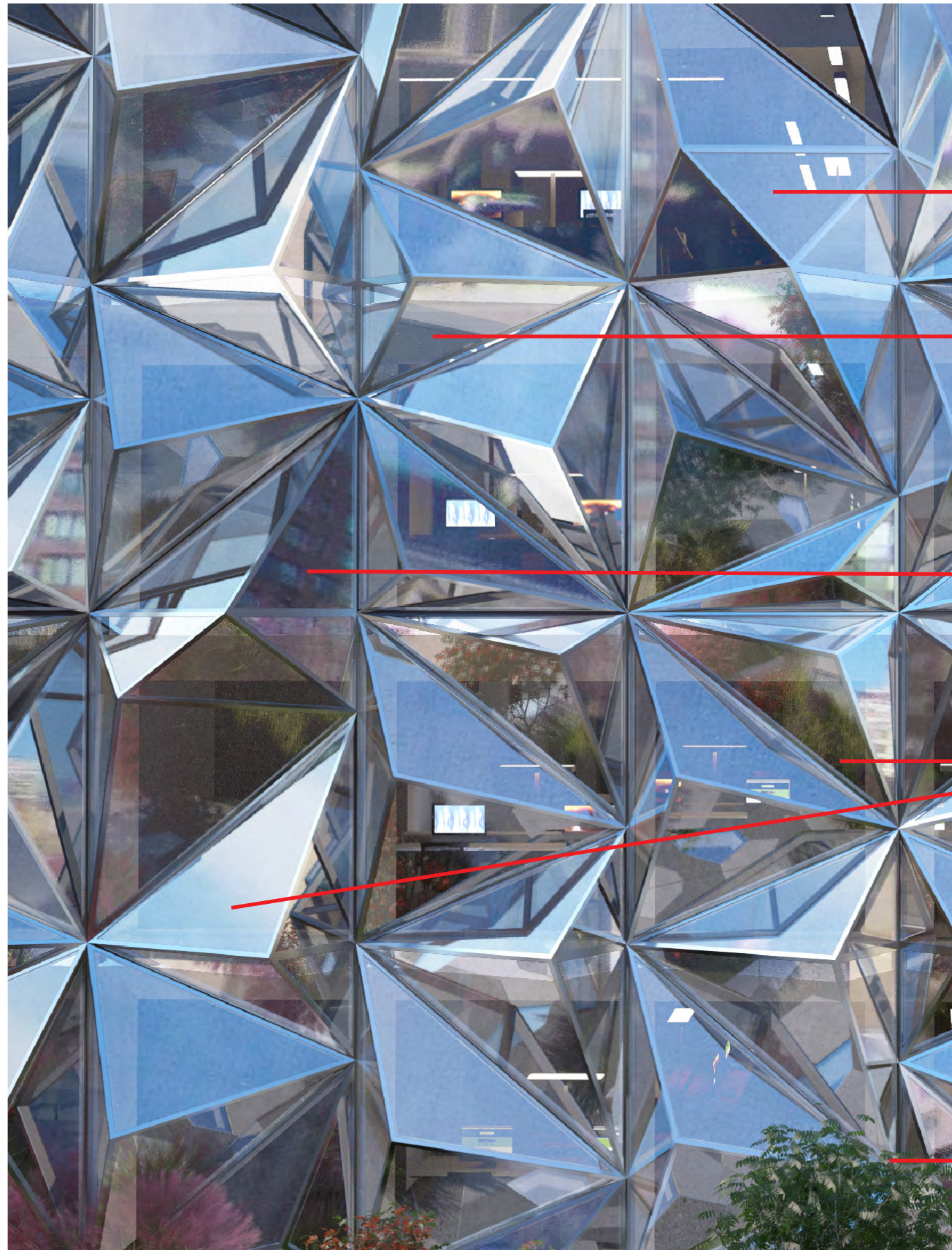

**SYNTHESIS;**  
ABSTRACTION OF SURROUNDING CONTEXT, REFLECTION  
OF DYNAMIC QUALITIES OF SITE AND CELEBRATION OF  
DE KOONINGS TRANSITION IN SUBJECT AND TECHNIQUE  
THAT HAPPENED AT 831 BROADWAY.

**GLAZING:**  
GLAZING REFLECTANCE OUT - 25% (16% REDUCTION)  
GLAZING TRANSMISSION IN - 58% (34% INCREASE)

**8 BAY COLUMN GRID:**  
STRUCTURAL GRID BEHIND THE GLAZING THAT  
REFLECTS THE RHYTHM AND FORM OF THE EXISTING  
BROADWAY FACADE

**BUILDING AND CITYSCAPE REFLECTION;**  
REPRESENTATIVE OF DE KOONINGS URBAN LANDSCAPE  
PHASE (LATE 1950`S)

**LANDSCAPE AND SKY REFLECTION;**  
REPRESENTATIVE OF DE KOONINGS RURAL AND PASTORAL  
LANDSCAPE PHASE (EARLY 1960`S)

**DYNAMIC, EVERCHANGING LANDSCAPE;**  
ROTATING FLOWERING INDIGENOUS SPECIES PROVIDE CHANGING  
COLOR FIELDS REFLECTED IN FACADES.

827-831 BROADWAY - VISUALIZATION - FACADE REFLECTION DETAIL



**DXA studio** 894 6th Avenue  
5th Floor  
NYC 10001  
dxastudio.com T 212 874 0567

**SCALE** As Noted  
**CLIENT** BH Quality Broadway Investors  
**PROJECT NUMBER** 17.32  
**DATE** April 24th 2018



1.



2.



3.



4.



5.



6.

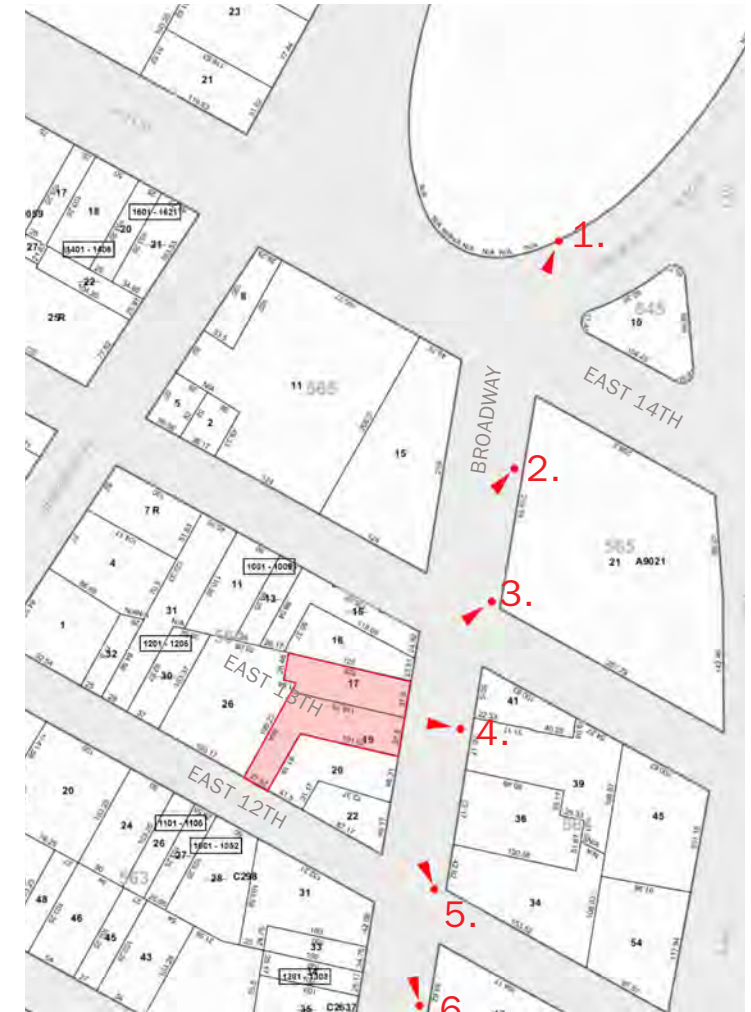

VIEW LOCATIONS



**DXA studio**

dxastudio.com

894 6th Avenue  
5th Floor  
NYC 10001  
T 212 874 0567

**827-831 BROADWAY - VISUALIZATION - FLY-THROUGH ANIMATION**

**SCALE** As Noted  
**CLIENT** BH Quality Broadway Investors  
**PROJECT NUMBER** 17.32  
**DATE** April 24th 2018

**20**



827-831 BROADWAY - MAP SHOWING ANIMATION PATH AND VISIBILITY



**DXA studio**  
894 6th Avenue  
5th Floor  
NYC 10001  
T 212 874 0567  
dxastudio.com

**SCALE** As Noted  
**CLIENT** BH Quality Broadway Investors  
**PROJECT NUMBER** 17.32  
**DATE** April 24th 2018



827-831 BROADWAY - PRIOR DESIGN (1/9/18) - VANTAGE POINT OF GREATEST VISIBILITY - DAY



**DXA studio**  
 894 6th Avenue  
 5th Floor  
 NYC 10001  
 T 212 874 0567  
 dxastudio.com

**SCALE** As Noted  
**CLIENT** BH Quality Broadway Investors  
**PROJECT NUMBER** 17.32  
**DATE** April 24th 2018



827-831 BROADWAY - REVISED DESIGN - VANTAGE POINT OF GREATEST VISIBILITY - DAY



**DXA studio**  
894 6th Avenue  
5th Floor  
NYC 10001  
T 212 874 0567  
dxastudio.com

**SCALE** As Noted  
**CLIENT** BH Quality Broadway Investors  
**PROJECT NUMBER** 17.32  
**DATE** April 24th 2018



827-831 BROADWAY - REVISED DESIGN - VANTAGE POINT OF GREATEST VISIBILITY - NIGHT



**DXA studio**  
894 6th Avenue  
5th Floor  
NYC 10001  
T 212 874 0567  
dxastudio.com

**SCALE** As Noted  
**CLIENT** BH Quality Broadway Investors  
**PROJECT NUMBER** 17.32  
**DATE** April 24th 2018





827-831 BROADWAY - PRIOR DESIGN (1/9/18) - STREET VIEW FROM UNION SQUARE DAY - DAY



**DXA studio**

894 6th Avenue  
5th Floor  
NYC 10001  
T 212 874 0567

dxastudio.com

**SCALE**

As Noted

**CLIENT**

BH Quality Broadway Investors

**PROJECT NUMBER**

17.32

**DATE**

April 24th 2018

**25**



827-831 BROADWAY - REVISED DESIGN - STREET VIEW FROM UNION SQUARE DAY - DAY



**DXA studio**

894 6th Avenue  
5th Floor  
NYC 10001  
T 212 874 0567

dxastudio.com

**SCALE**  
**CLIENT**  
**PROJECT NUMBER**  
**DATE**

As Noted  
BH Quality Broadway Investors  
17.32  
April 24th 2018

**26**



827-831 BROADWAY - PRIOR DESIGN (1/9/18) - STREET VIEW WEST



**DXA studio**

dxastudio.com

894 6th Avenue  
5th Floor  
NYC 10001  
T 212 874 0567

**SCALE**

**CLIENT**

**PROJECT NUMBER**

**DATE**

As Noted

BH Quality Broadway Investors

17.32

April 24th 2018

**27**



827-831 BROADWAY - REVISED DESIGN - STREET VIEW WEST



**DXA studio**

894 6th Avenue  
5th Floor  
NYC 10001  
T 212 874 0567

dxastudio.com

**SCALE**

As Noted

**CLIENT**

BH Quality Broadway Investors

**PROJECT NUMBER**

17.32

**DATE**

April 24th 2018

**28**

FOUR STORY ADDITION

EXISTING HISTORIC FACADE

STRUCTURAL COLUMN GRID

GLAZED FACADE

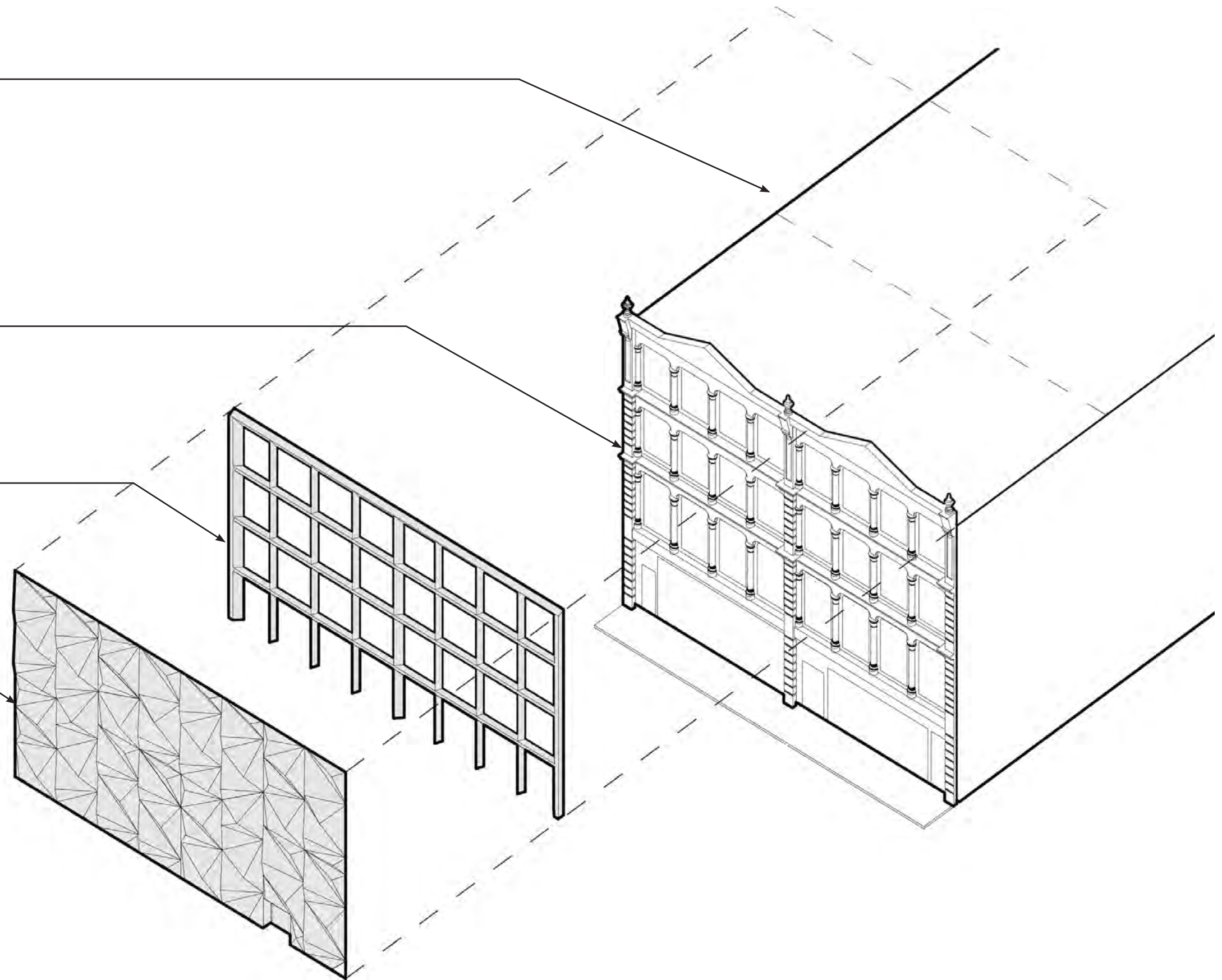

827-831 BROADWAY - FACADE DESIGN - FOSTER DIALOGUE WITH EXISTING BUILDING



**DXA studio**  
 894 6th Avenue  
 5th Floor  
 NYC 10001  
 T 212 874 0567  
 dxastudio.com

**SCALE** As Noted  
**CLIENT** BH Quality Broadway Investors  
**PROJECT NUMBER** 17.32  
**DATE** April 24th 2018



MORNING VIEW



LATE AFTERNOON VIEW

827-831 BROADWAY - REVISED DESIGN - VANTAGE POINT OF GREATEST VISIBILITY - DAY - ZOOM IN



**DXA studio**

894 6th Avenue  
5th Floor  
NYC 10001  
T 212 874 0567

dxastudio.com

**SCALE**

As Noted

**CLIENT**

BH Quality Broadway Investors

**PROJECT NUMBER**

17.32

**DATE**

April 24th 2018

**30**



EVENING VIEW



NIGHT VIEW

827-831 BROADWAY - REVISED DESIGN - VANTAGE POINT OF GREATEST VISIBILITY - NIGHT - ZOOM IN



**DXA studio**  
 894 6th Avenue  
 5th Floor  
 NYC 10001  
 T 212 874 0567  
 dxastudio.com

**SCALE** As Noted  
**CLIENT** BH Quality Broadway Investors  
**PROJECT NUMBER** 17.32  
**DATE** April 24th 2018

4'-6" MAXIMUM PROJECTION

3'-6" MAXIMUM PROJECTION

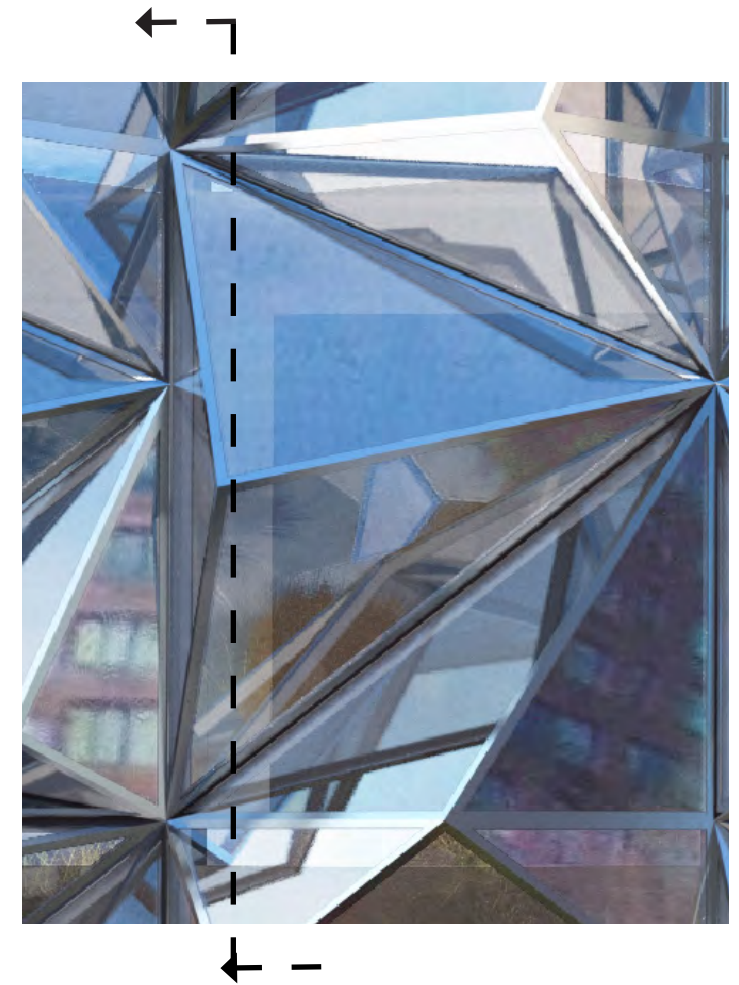
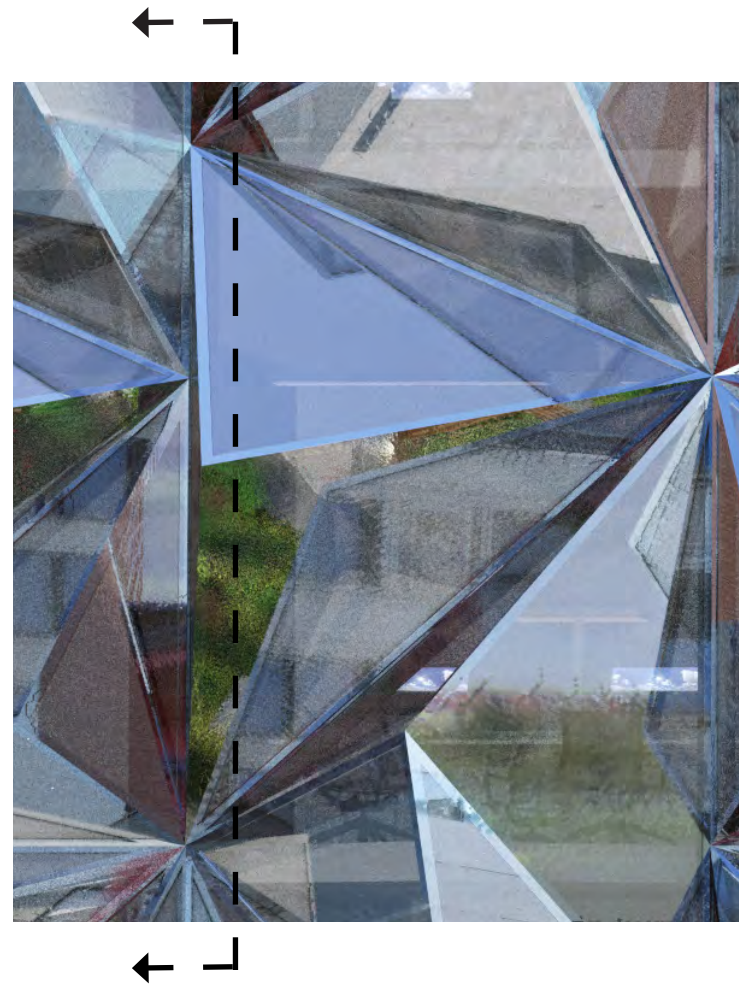
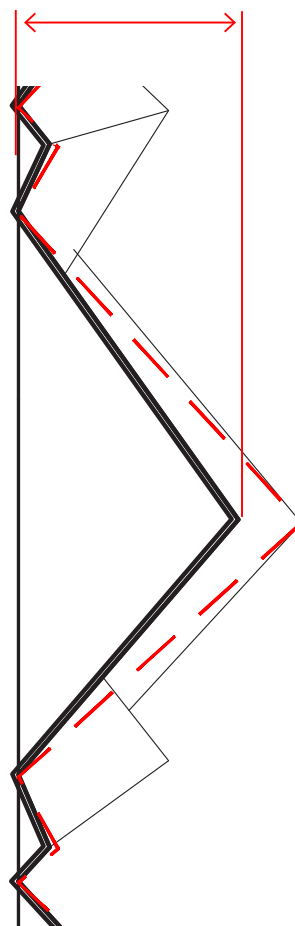
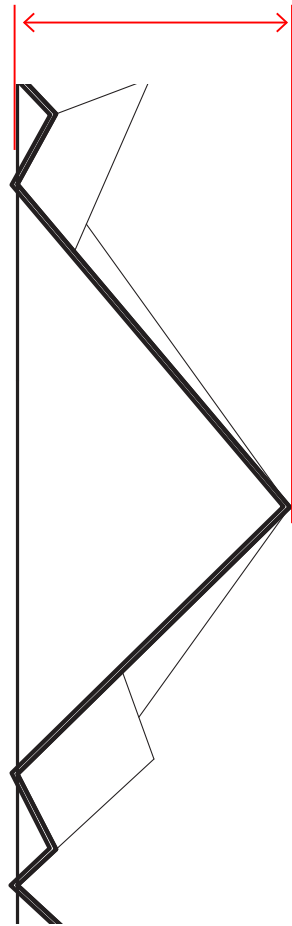

**PRIOR DESIGN (1/9/18)**  
\_FACADE SECTION SHOWING  
MAXIMUM FACET PROJECTION

**REVISED DESIGN**  
\_FACADE SECTION SHOWING  
PROJECTIONS REDUCED BY 1'-0"

**PRIOR DESIGN (1/9/18)**  
\_4'-6" MAXIMUM PROJECTION DEPTH  
\_GLAZING REFLECTANCE OUT = 30%  
\_GLAZING LIGHT TRANSMISSION IN = 43%

**REVISED DESIGN**  
\_3'-6" MAXIMUM PROJECTION DEPTH  
\_GLAZING REFLECTANCE OUT = 25% (16% REDUCTION)  
\_GLAZING TRANSMISSION IN = 58% (34% INCREASE)



**DXA studio** 894 6th Avenue  
5th Floor  
NYC 10001  
T 212 874 0567  
dxastudio.com

827-831 BROADWAY - **FACADE DESIGN** - REDUCTION IN FACET PROJECTION DEPTH

**SCALE** As Noted  
**CLIENT** BH Quality Broadway Investors  
**PROJECT NUMBER** 17.32  
**DATE** April 24th 2018



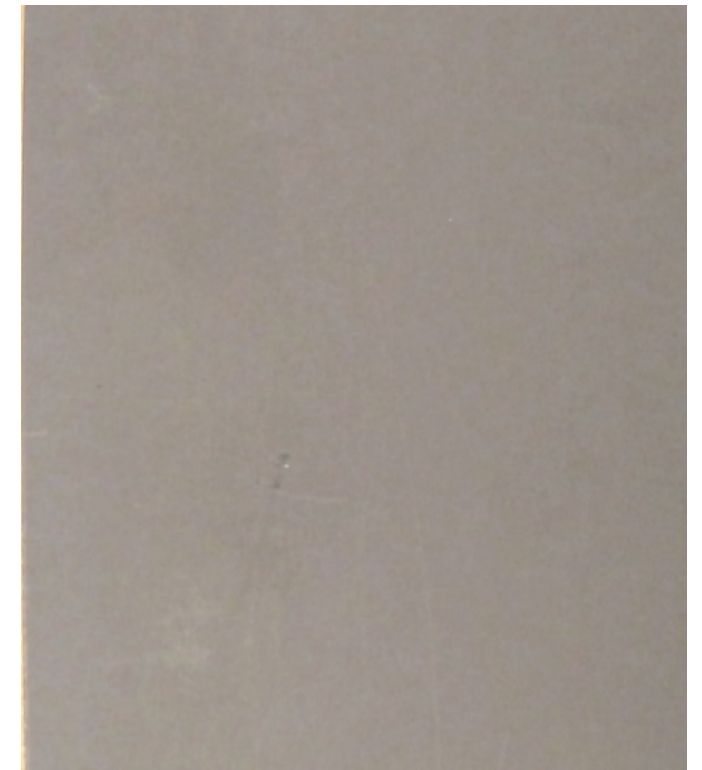
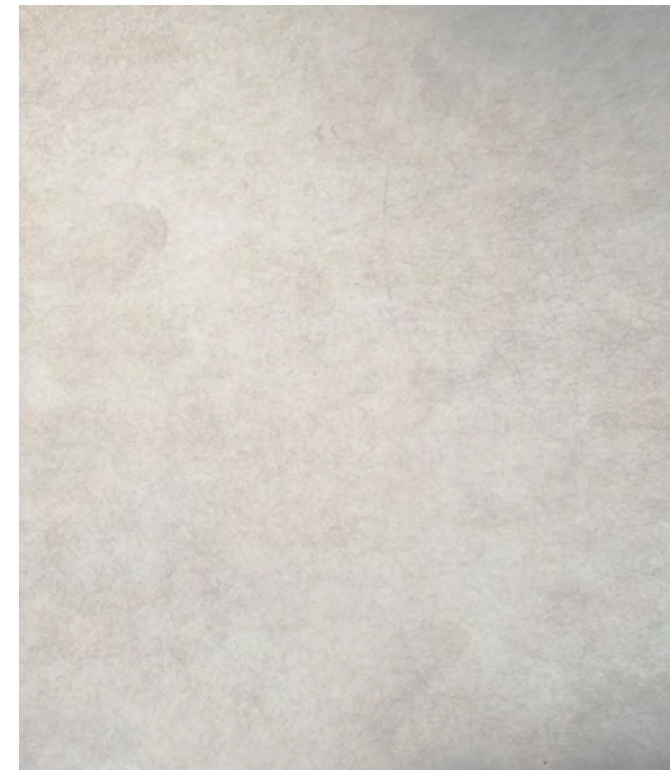
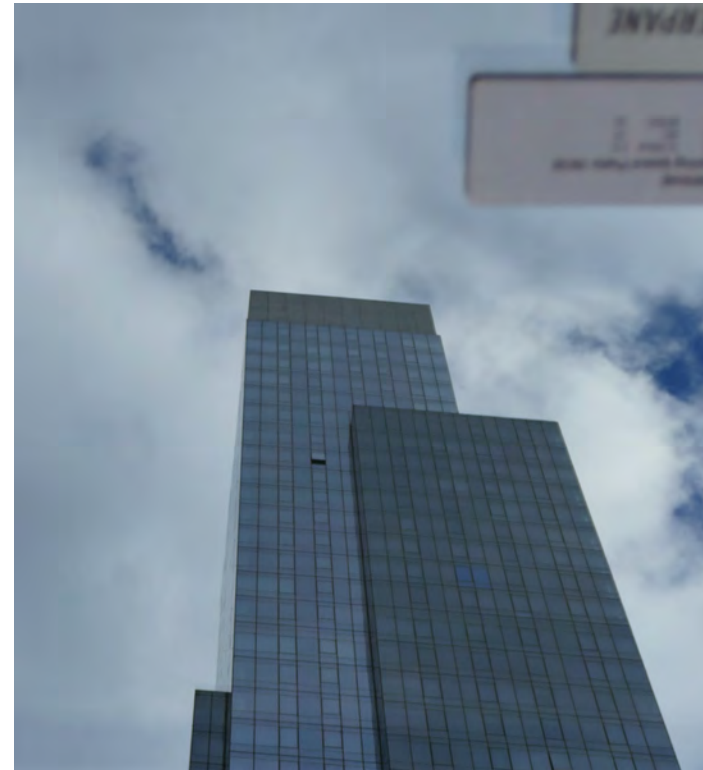
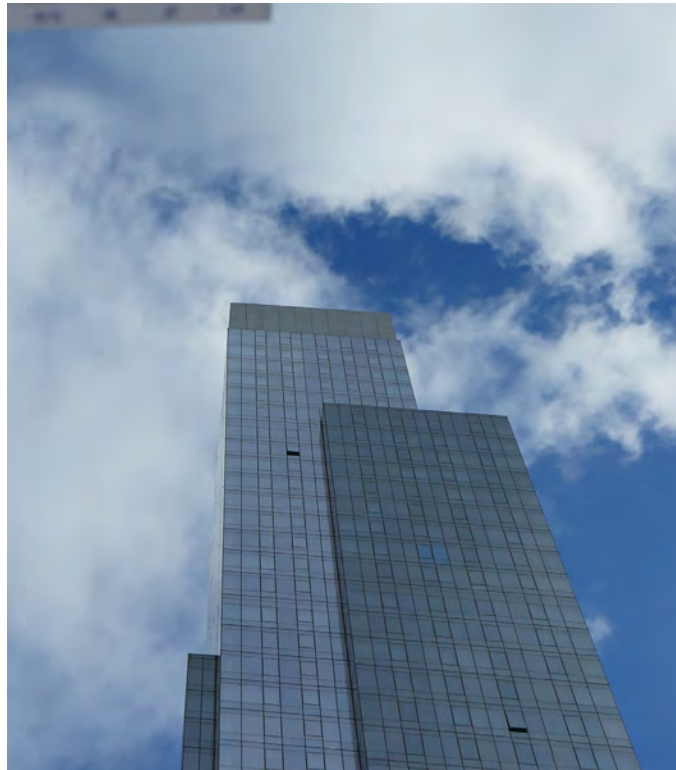
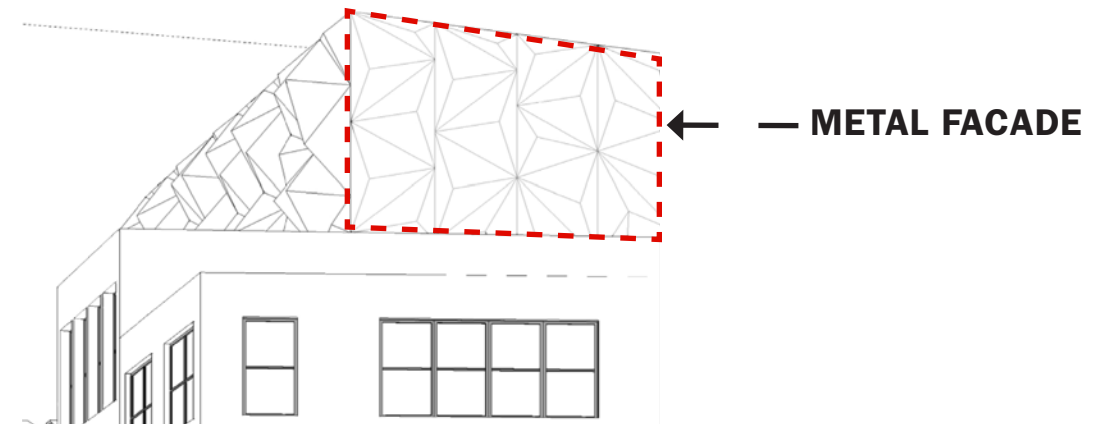
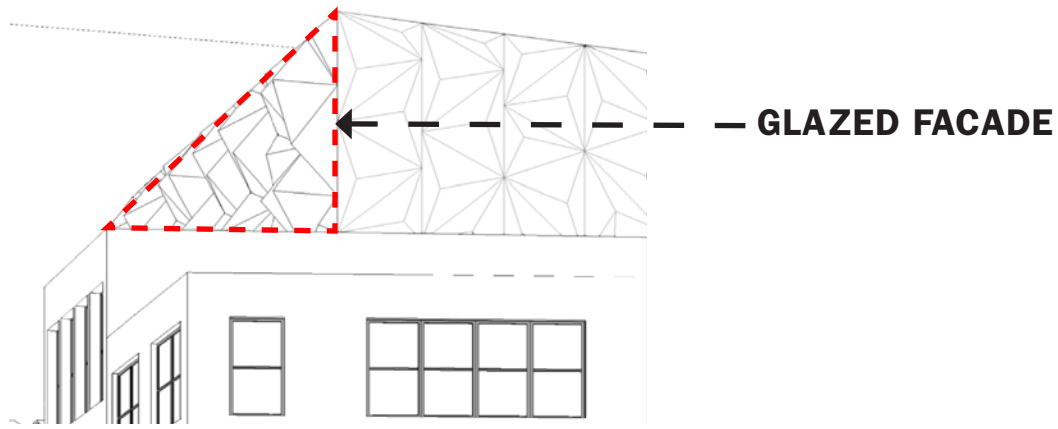

**PRIOR DESIGN (1/9/18)**  
**- PHOTO OF GLAZING SAMPLE**  
**SHOWING REFLECTION**  
 \_GLAZING REFLECTANCE OUT = 30%  
 \_GLAZING LIGHT TRANSMISSION IN = 43%

**REVISED DESIGN**  
**- PHOTO OF GLAZING SAMPLE**  
**SHOWING REFLECTION**  
 \_GLAZING REFLECTANCE OUT = 25% (16% REDUCTION)  
 \_GLAZING TRANSMISSION IN = 58% (34% INCREASE)

**PRIOR DESIGN (1/9/18)**  
**- METAL SAMPLE**  
 \_STAINLESS STEEL WITH ANGEL HAIR  
 FINISH METAL RAINSCREEN

**REVISED DESIGN**  
**- METAL SAMPLE**  
 \_MEDIUM GREY METAL RAINSCREEN



**DXA studio**  
 894 6th Avenue  
 5th Floor  
 NYC 10001  
 T 212 874 0567  
 dxastudio.com

827-831 BROADWAY - **FACADE DESIGN** - REDUCTION IN GLASS REFLECTIVITY & TEMPERING OF METAL FACADE FINISH

**SCALE** As Noted  
**CLIENT** BH Quality Broadway Investors  
**PROJECT NUMBER** 17.32  
**DATE** April 24th 2018



MORNING VIEW

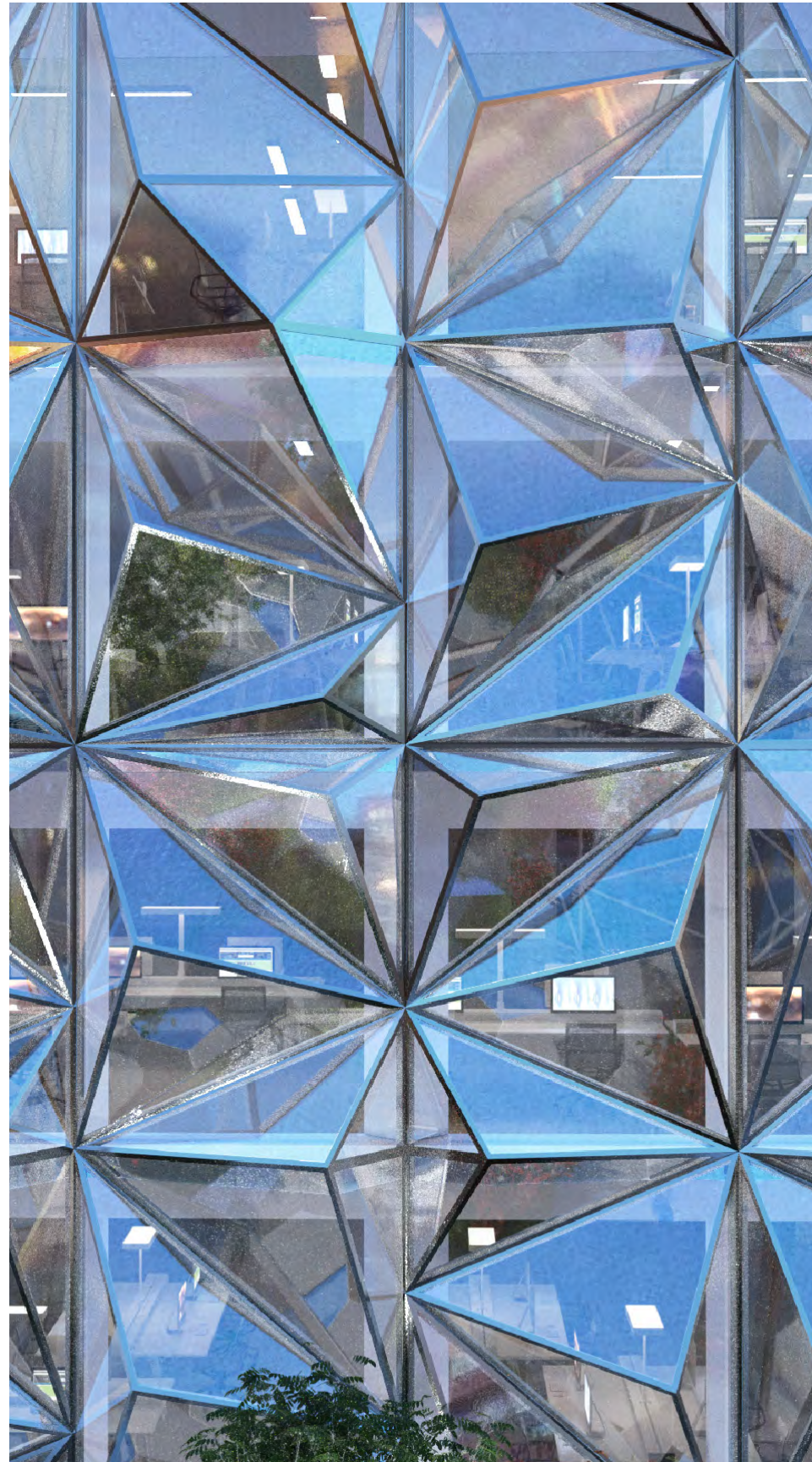

LATE AFTERNOON VIEW

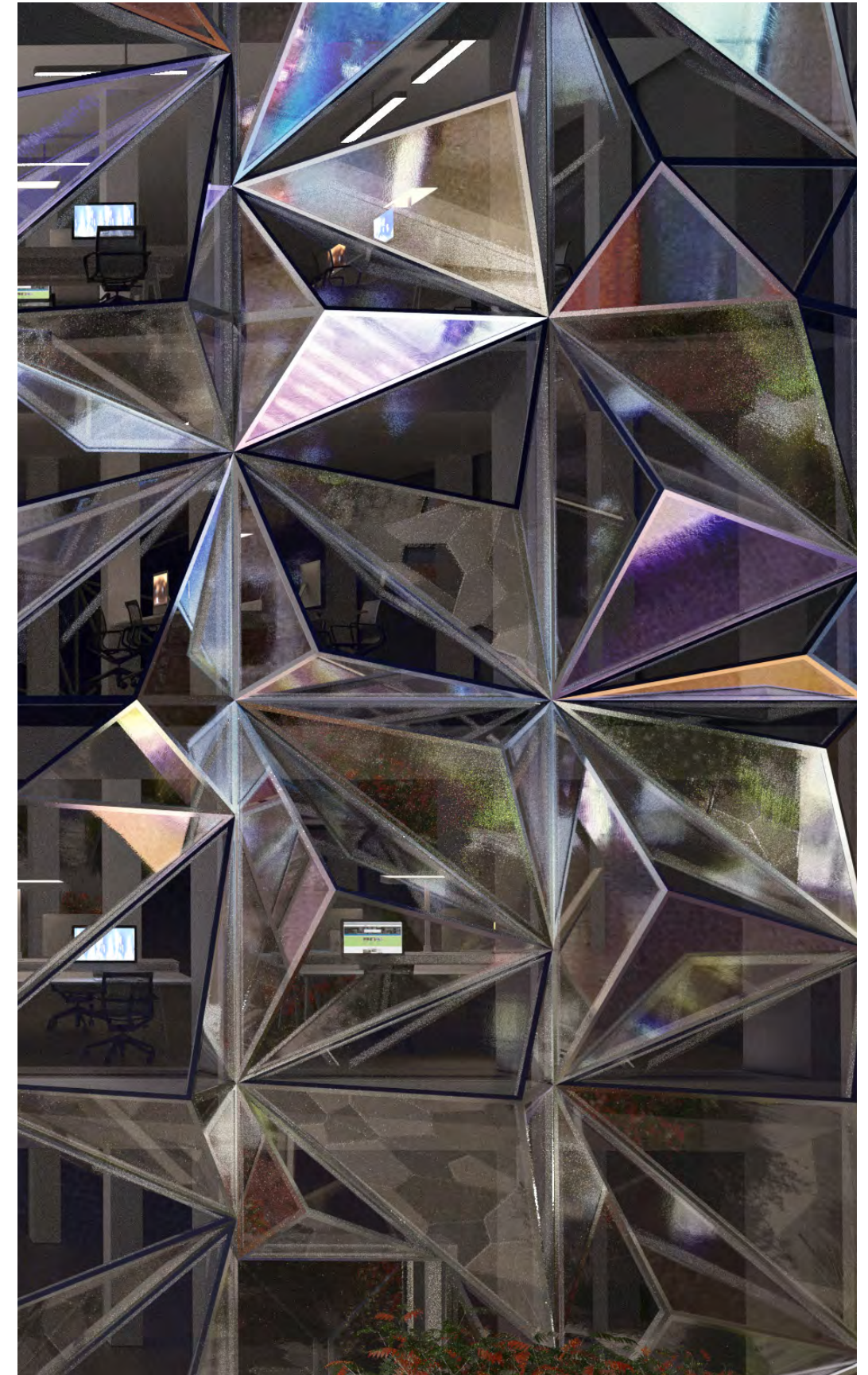

NIGHT VIEW

827-831 BROADWAY - VISUALIZATION - BROADWAY FACADE ALL TIMES



**DXA studio**

894 6th Avenue  
5th Floor  
NYC 10001  
T 212 874 0567

dxastudio.com

**SCALE**  
**CLIENT**  
**PROJECT NUMBER**  
**DATE**

As Noted  
BH Quality Broadway Investors  
17.32  
April 24th 2018

**34**

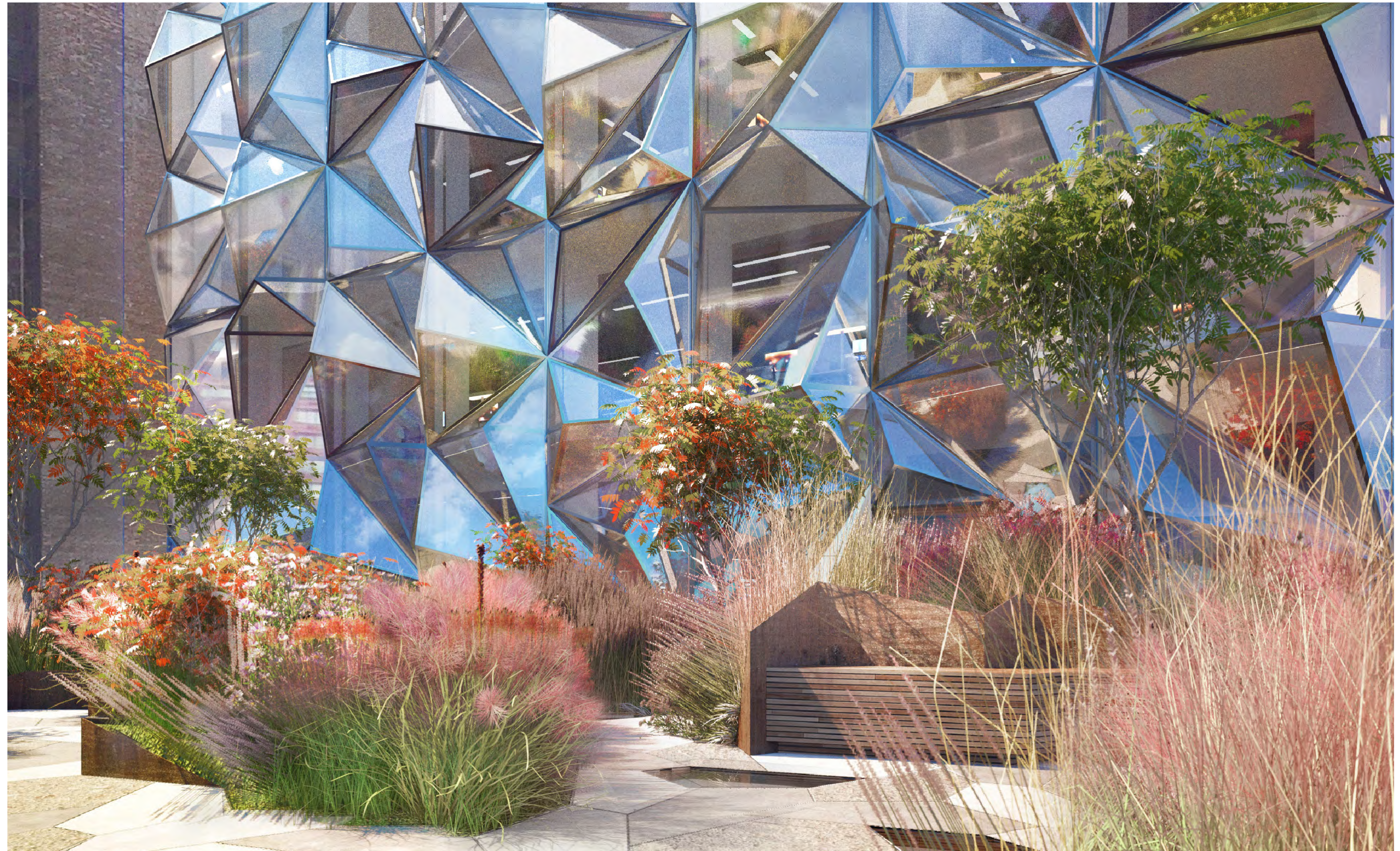

827-831 BROADWAY - VISUALIZATION - FIFTH FLOOR TERRACE VIEW - DAY



**DXA studio**

894 6th Avenue  
5th Floor  
NYC 10001  
T 212 874 0567

[dxastudio.com](http://dxastudio.com)

**SCALE**

As Noted

**CLIENT**

BH Quality Broadway Investors

**PROJECT NUMBER**

17.32

**DATE**

April 24th 2018

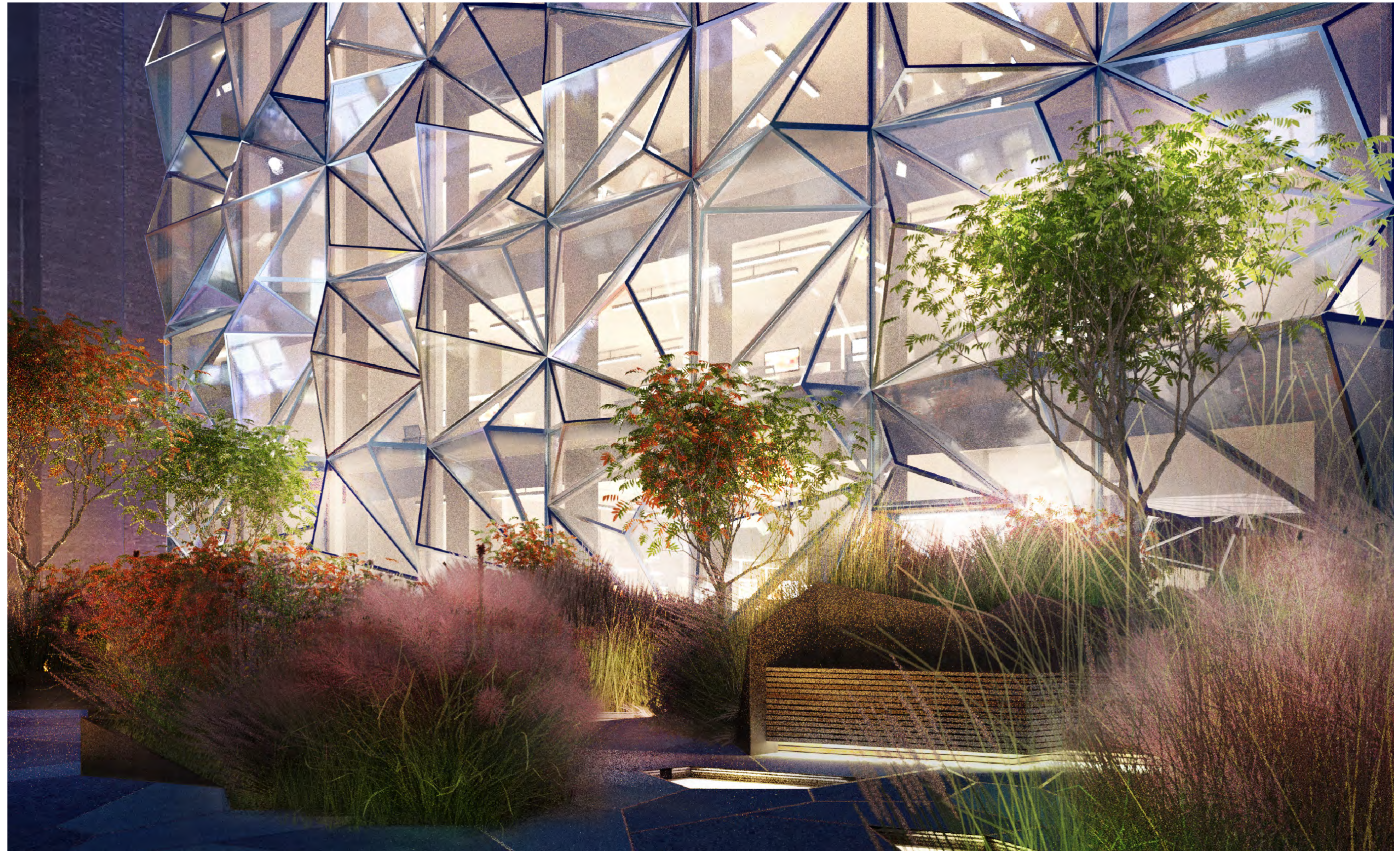

827-831 BROADWAY - FIFTH FLOOR BROADWAY TERRACE VIEW AT NIGHT



**DXA studio**  
894 6th Avenue  
5th Floor  
NYC 10001  
T 212 874 0567  
dxastudio.com

**SCALE** As Noted  
**CLIENT** BH Quality Broadway Investors  
**PROJECT NUMBER** 17.32  
**DATE** April 24th 2018

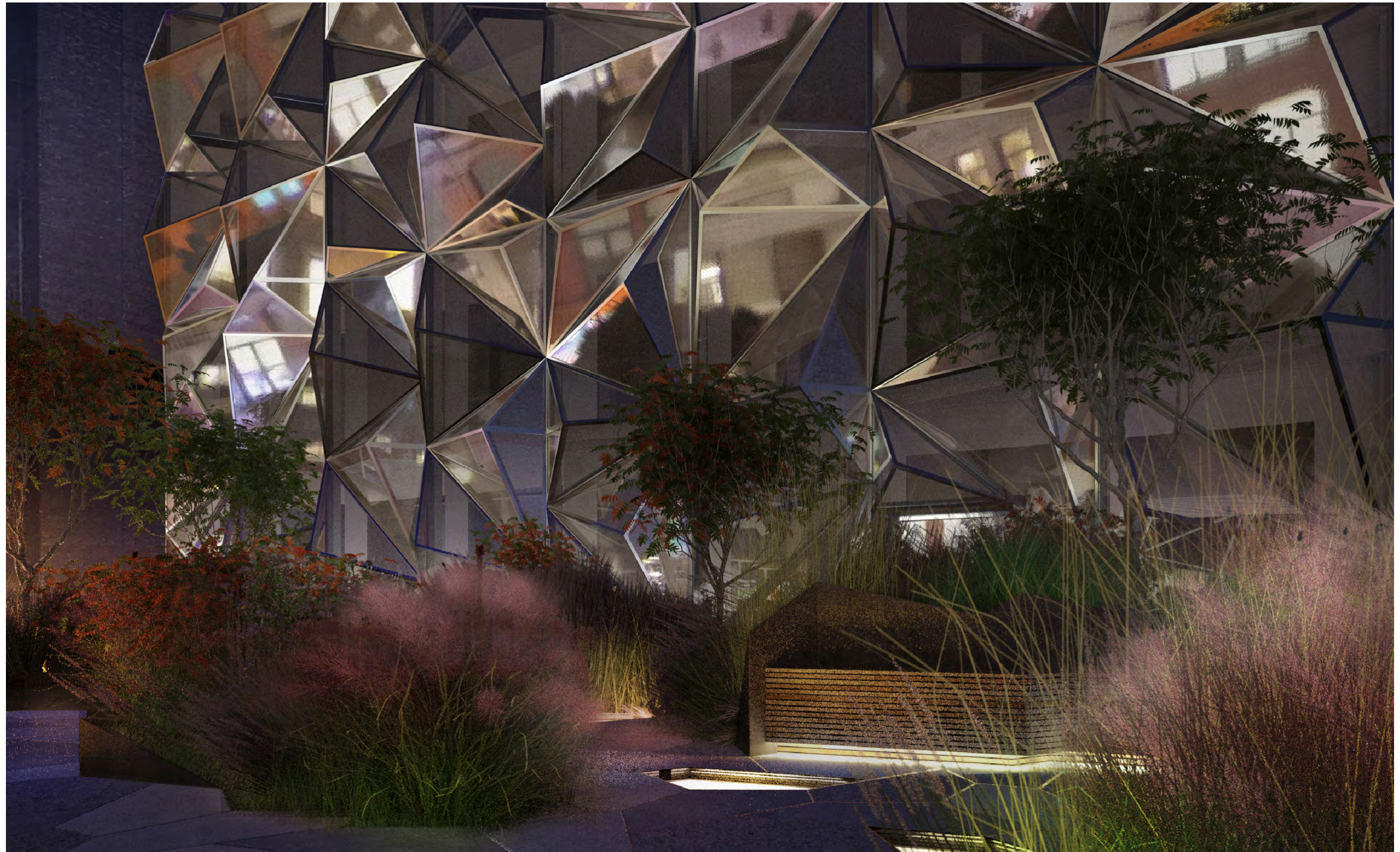

827-831 BROADWAY - FIFTH FLOOR BROADWAY TERRACE VIEW AT NIGHT



**DXA studio**  
894 6th Avenue  
5th Floor  
NYC 10001  
T 212 874 0567  
dxastudio.com

**SCALE** As Noted  
**CLIENT** BH Quality Broadway Investors  
**PROJECT NUMBER** 17.32  
**DATE** April 24th 2018

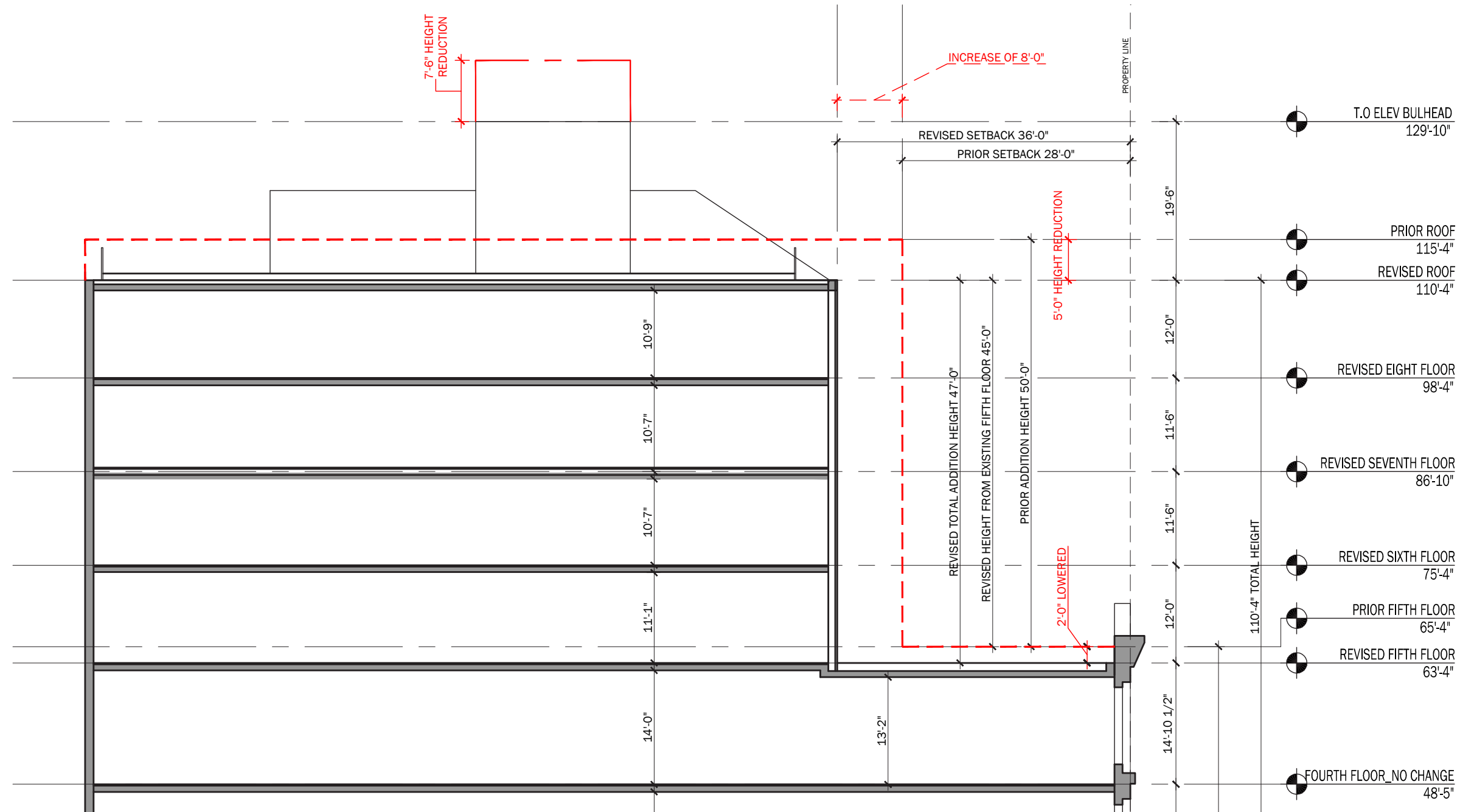
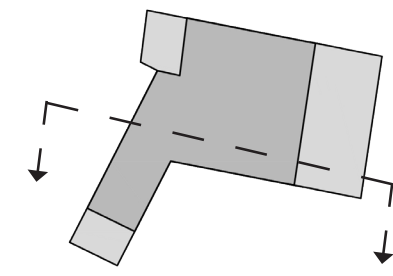

827-831 BROADWAY · MASSING SECTION THROUGH ADDITION



**DXA studio**  
 894 6th Avenue  
 5th Floor  
 NYC 10001  
 dxastudio.com T 212 874 0567

**SCALE** As Noted  
**CLIENT** BH Quality Broadway Investors  
**PROJECT NUMBER** 17.32  
**DATE** April 24th 2018



**DXA studio**

894 6th Avenue  
5th Floor  
NYC 10001  
T 212 874 0567

dxastudio.com

**827-831 BROADWAY · SITE PLAN**

**SCALE** As Noted  
**CLIENT** BH Quality Broadway Investors  
**PROJECT NUMBER** 17.32  
**DATE** April 24th 2018

**39**

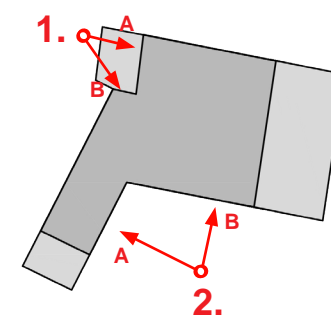

KEY PLAN

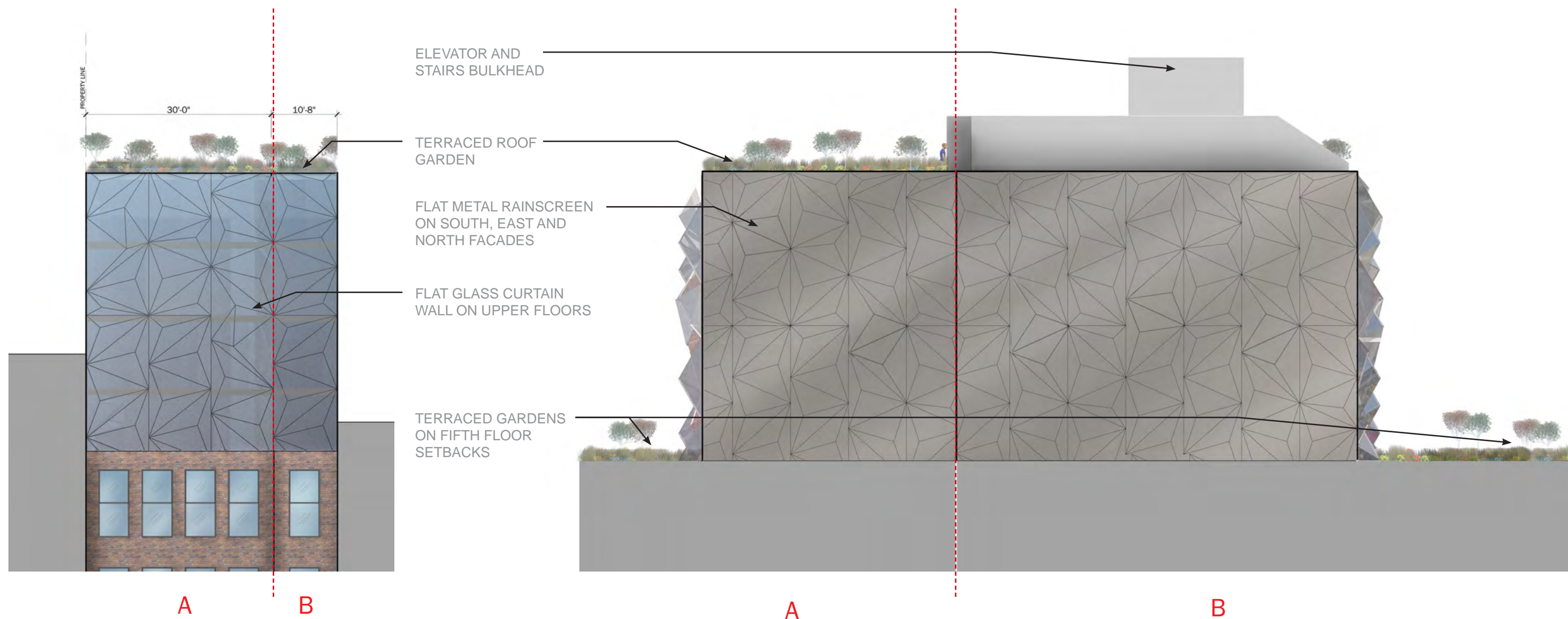

1. REAR ELEVATIONS - UNFOLDED

2. SOUTH SIDE ELEVATIONS - UNFOLDED



**DXA studio**  
 894 6th Avenue  
 5th Floor  
 NYC 10001  
 T 212 874 0567  
 dxastudio.com

827-831 BROADWAY · PROPOSED ADDITION ELEVATIONS

**SCALE** As Noted  
**CLIENT** BH Quality Broadway Investors  
**PROJECT NUMBER** 17.32  
**DATE** April 24th 2018



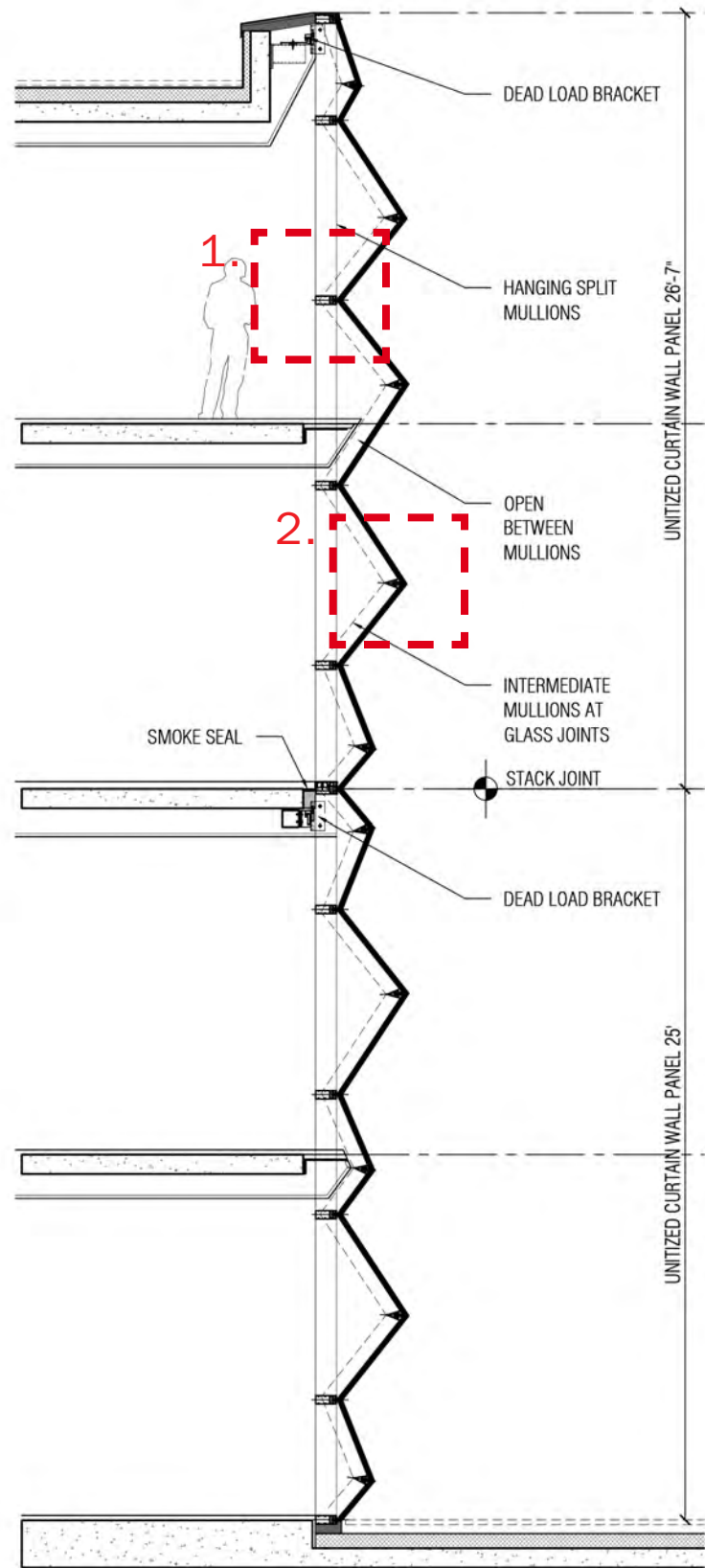

GLASS FACADE DETAIL SECTION

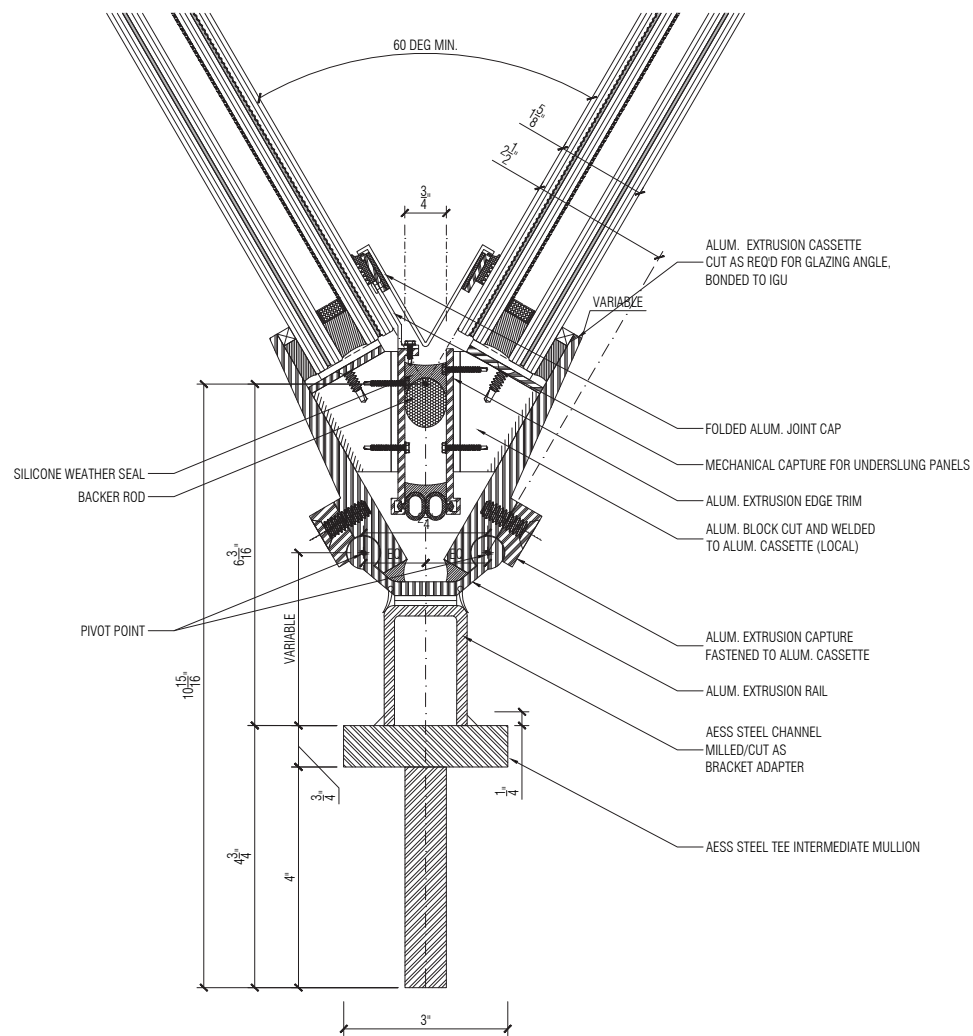

1. TYPICAL FACETED DETAIL - DEPRESSED GLAZING

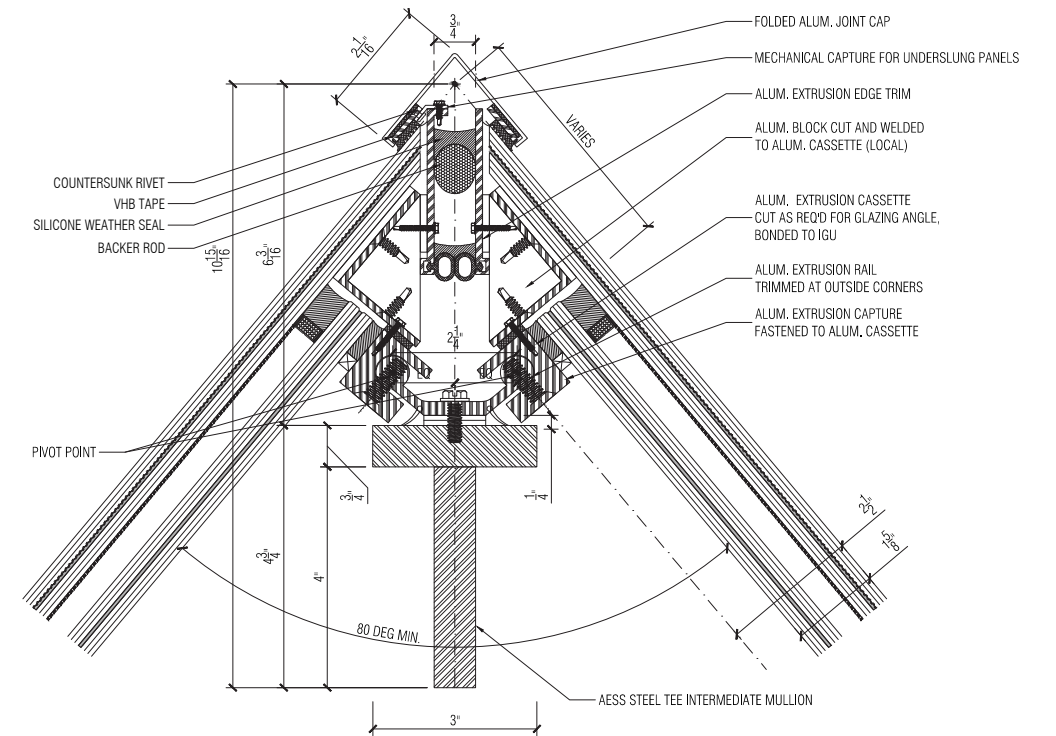

2. TYPICAL FACETED DETAIL - PROJECTED GLAZING

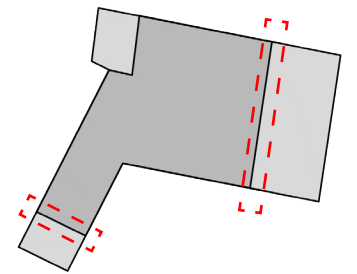

KEY PLAN





1. DETAIL VIEW OF FRAMING AT SPLIT MULLION



2. DETAIL VIEW OF FRAMING AT INTERMEDIATE NODE

827-831 BROADWAY · FACADE DESIGN - PRIMARY FACADE GLAZING \_INTERIOR DETAILS



**DXA studio**

894 6th Avenue  
5th Floor  
NYC 10001  
T 212 874 0567

dxastudio.com

**SCALE**  
**CLIENT**  
**PROJECT NUMBER**  
**DATE**

As Noted  
BH Quality Broadway Investors  
17.32  
April 24th 2018

**42**



827-831 BROADWAY · FACADE DESIGN - PRIMARY FACADE GLAZING INTERIOR VISUALIZATION



**DXA studio**

894 6th Avenue  
5th Floor  
NYC 10001  
T 212 874 0567

dxastudio.com

**SCALE**  
**CLIENT**  
**PROJECT NUMBER**  
**DATE**

As Noted  
BH Quality Broadway Investors  
17.32  
April 24th 2018

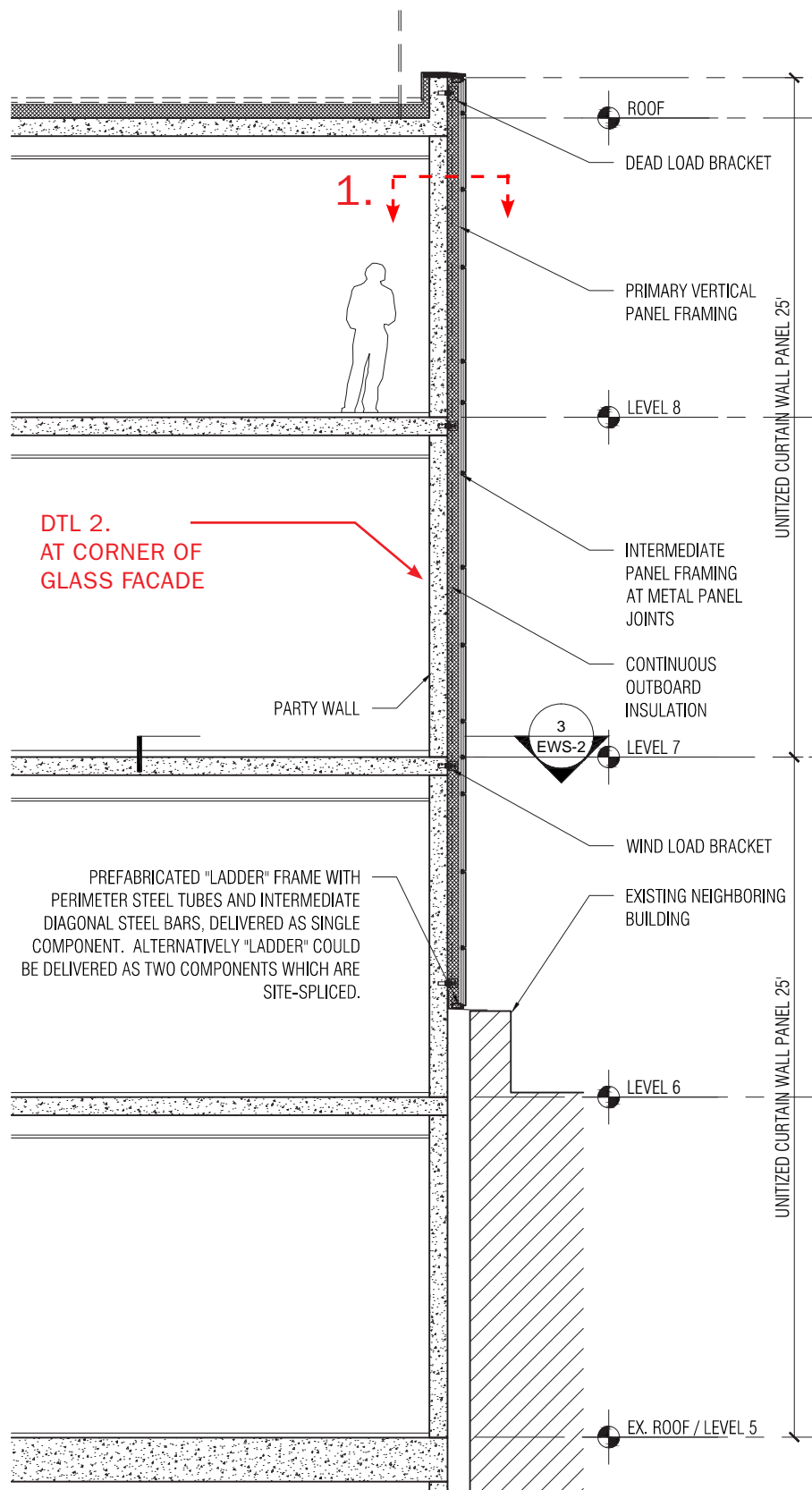

METAL RAINSCREEN FACADE DETAIL SECTION

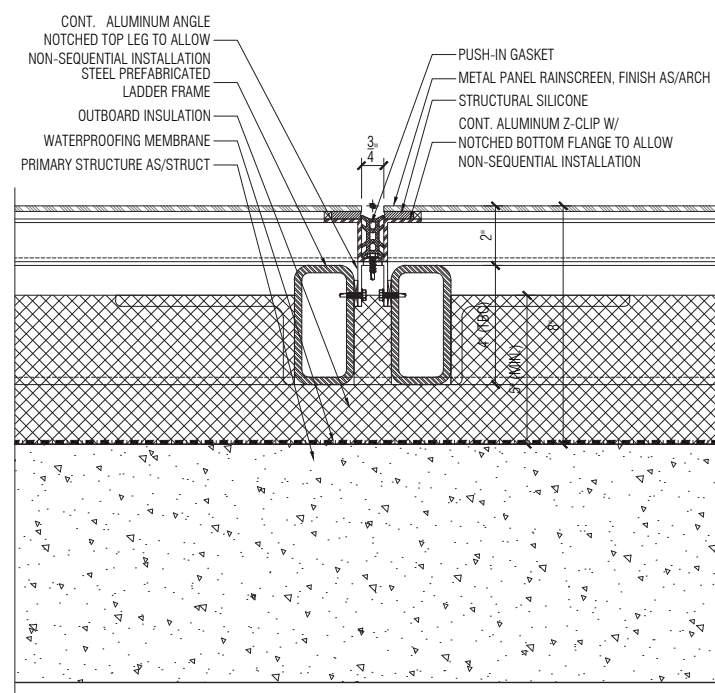

1. TYPICAL PANEL JOINT AT LADDER FRAME\_PLAN DETAIL

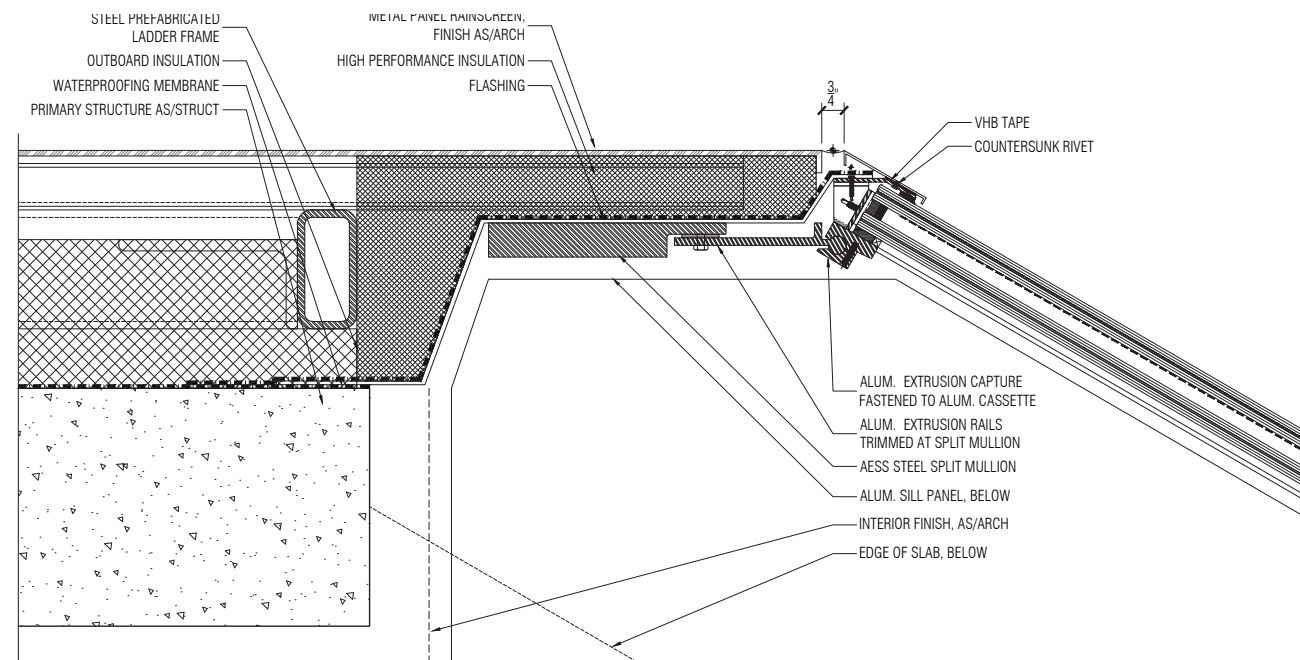

2. TYPICAL TRANSITION BETWEEN GLASS AND METAL FACADES\_PLAN DETAIL

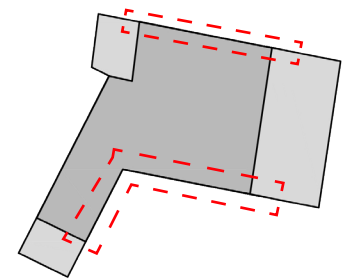

KEY PLAN



**NEW YORK**



TAMMANY HALL  
- BSK



837 WASHINGTON  
- MORRIS ADJMI ARCHITECTS



DVF STUDIO HEADQUARTERS  
- WORK AC

**EUROPE**



ELBPHILHARMONIE, HAMBURG, GERMANY  
- HERZOG AND DE MEURON



9-19 9TH AVE  
- BSK



67 FRANKLIN STREET - CAST IRON HOUSE  
- SHIGERU BAN



50 HUDSON  
- JACOBSON SHINODA ARCHITECTS

827-831 BROADWAY · ARCHITECTURAL PRECEDENTS: ADAPTIVE REUSE PROJECTS



**DXA studio**  
894 6th Avenue  
5th Floor  
NYC 10001  
T 212 874 0567  
dxastudio.com

**SCALE** As Noted  
**CLIENT** BH Quality Broadway Investors  
**PROJECT NUMBER** 17.32  
**DATE** April 24th 2018

**45**

<b>Judith Zilczer, Ph.D.</b>	<ul style="list-style-type: none"> <li>• Curator of Paintings at the Smithsonian Institution's Hirshhorn Museum and Sculpture Garden (1974-2003)</li> <li>• Author of <i>A Way of Living: The Art of Willem de Kooning</i> (2014)</li> </ul>	<p><i>"The faceted glass façade, to be set back above the original building, brilliantly evokes the complex, multilayered surfaces and expansive visual fields of mid-century New York School painting, most particularly Willem de Kooning's abstract urban landscapes. At the same time, the faceted glass surfaces promise to capture, reconfigure, and reflect the surrounding neighborhood in much the same way that de Kooning drew inspiration from his urban surroundings."</i></p>
Todd D .Weyman	<ul style="list-style-type: none"> <li>• VP, Director, Swann Auction Galleries (104 E. 25th Street)</li> <li>• Art historian and specialist in the works of the New York School Abstract Expressionists</li> </ul>	<p><i>"DXA Studio's design proposal for the site celebrates and embodies the contributions of these Abstract Expressionist artist tenants of 827-831 Broadway . . ."</i></p>
Ty Osbaugh, AIA	<ul style="list-style-type: none"> <li>• Principal, Gensler Architecture, Design &amp; Planning, P.C.</li> </ul>	<p><i>"This concept simultaneously speaks to New York's distinctive contemporary architecture and the history of the building which plays host to it."</i></p>
Joseph Wheeler	<ul style="list-style-type: none"> <li>• Co-Director, Center for Design Research, Professor of Architecture and Urban Studies, Virginia Tech</li> </ul>	<p><i>"DXA has managed to preserve the historic fabric of the existing building while integrating an addition that responds to the rich cultural history of the movement that is unique to this building."</i></p>
Cameron Wu	<ul style="list-style-type: none"> <li>• Associate Professor of Architecture, Harvard University Graduate School of Design</li> </ul>	<p><i>"I believe that the restoration and proposed new building is both beautifully elegant in its form and design while also retaining a close symbiosis with the existing historic structure below."</i></p>
Claire Oliver	<ul style="list-style-type: none"> <li>• Sole owner and operator, Claire Oliver Gallery (513 W. 26th Street)</li> </ul>	<p><i>"The glass addition is in scale, space and form an architectural element that will animate the streetscape and bring a new energy and life to the space, allowing the observer to connect with clarity, light and energy."</i></p>
Mark Bearak, RA	<ul style="list-style-type: none"> <li>• Principal, dtls.ARCHITECTURE</li> <li>• Associate Professor, Columbia University</li> </ul>	<p><i>"The latest design takes their concept to a more sophisticated level by building on the existing grid so that the new addition becomes a layered façade of complimentary geometries."</i></p>
Andrew O. Hughes	<ul style="list-style-type: none"> <li>• New York City-Based Artist</li> </ul>	<p><i>"The design is an effective synthesis of many considerations, balancing the new with the old, adopting concepts shared by the artists into an architectural framework, and raising awareness of the building's cultural and historic significance."</i></p>
Kevin Daly	<ul style="list-style-type: none"> <li>• Design Principal, Kevin Daly Architects</li> </ul>	<p><i>"The proposed project is thoughtfully conceived, rigorous in its conceptual development, and would be a transformative addition to the city."</i></p>
Maria Free	<ul style="list-style-type: none"> <li>• Urban Design and Architecture Student, NYU</li> </ul>	<p><i>"By attracting the public's attention, the project promotes interest in design rationale and cultural history."</i></p>



April 2, 2018

Hon. Meenakshi Srinivasan, Chair  
Commissioner  
Landmarks Preservation Commission  
1 Centre St., 9<sup>th</sup> Floor  
New York, NY 10007

Dear Chair Srinivasan:

DXA Studio has shared with me the revision of the proposed design for the preservation and renovation of the building at 827-831 Broadway. By combining an increased setback and reduced height for the faceted façade of the proposed addition to the original building, DXA designers have devised a subtle and nuanced response to the issues raised in the preliminary review earlier this year. The new design represents an improvement of their original submission and preserves the innovative spirit that I found so compelling in the initial design conception. I trust that the revised architectural plan will receive favorable consideration.

Yours respectfully,



Judith Zilczer, Ph.D.





INTERACTIVE PLAQUE

PROPOSED PLAQUE ON STOREFRONT ON CENTRAL QUOINING  
BETWEEN 827 AND 831

827-831 BROADWAY · PLAQUE ON BROADWAY STOREFRONT



**DXA studio**

894 6th Avenue  
5th Floor  
NYC 10001  
T 212 874 0567

dxastudio.com

**SCALE**  
**CLIENT**  
**PROJECT NUMBER**  
**DATE**

As Noted  
BH Quality Broadway Investors  
17.32  
April 24th 2018

**48**



**W**

**RESTORATION  
WORK**



831 BROADWAY - 1880

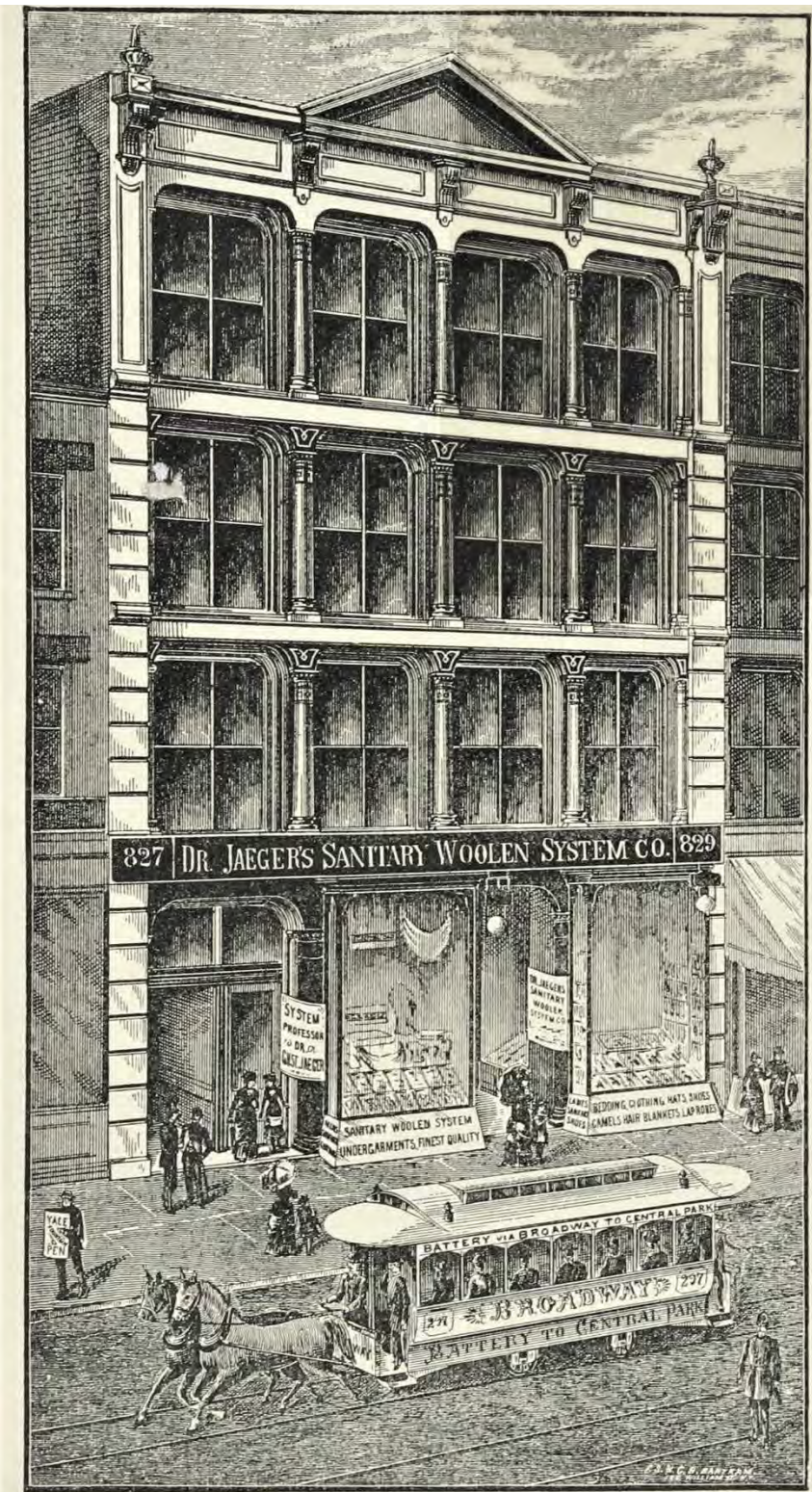

DR. JAEGER'S SANITARY WOOLEN SYSTEM CO.  
827-829 Broadway,  
NEW YORK.

827 BROADWAY - 1899

827-831 BROADWAY · HISTORIC PHOTOS

SCALE As Noted  
 CLIENT BH Quality Broadway Investors  
 PROJECT NUMBER 17.32  
 DATE April 24th 2018





TAX PHOTOS BUILDING  
- 827 CIRCA 1940



TAX PHOTOS BUILDING  
- 831 CIRCA 1940

827-831 BROADWAY · HISTORIC PHOTOS

SCALE As Noted  
 CLIENT BH Quality Broadway Investors  
 PROJECT NUMBER 17.32  
 DATE April 24th 2018





TAX PHOTOS BUILDING  
- 827 CIRCA 1980



TAX PHOTOS BUILDING  
- 831 CIRCA 1980

827-831 BROADWAY · HISTORIC PHOTOS

SCALE As Noted  
CLIENT BH Quality Broadway Investors  
PROJECT NUMBER 17.32  
DATE April 24th 2018



DXA studio

dxastudio.com

894 6th Avenue  
5th Floor  
NYC 10001  
T 212 874 0567



1980`S STOREFRONT WITH ORIGINAL CAST IRON COLUMN



ORIGINAL CAST IRON SIDE PILASTER



LOCATION OF GROUND FLOOR CORNICE



EARLY OR ORIGINAL PAIRED 1/1 SASH



FACADE WITH EXTRANEIOUS HARDWARE, OPEN JOINTS, FLAKING PAINT



STONE FINIAL AT ROOF HEAVILY COATED, RAIL PIERCING BASE

827-831 BROADWAY · PHOTOS OF EXISTING CONDITIONS



**DXA studio**  
894 6th Avenue  
5th Floor  
NYC 10001  
T 212 874 0567  
dxastudio.com

**SCALE** As Noted  
**CLIENT** BH Quality Broadway Investors  
**PROJECT NUMBER** 17.32  
**DATE** April 24th 2018

### Paint Sample Locations

827 Broadway

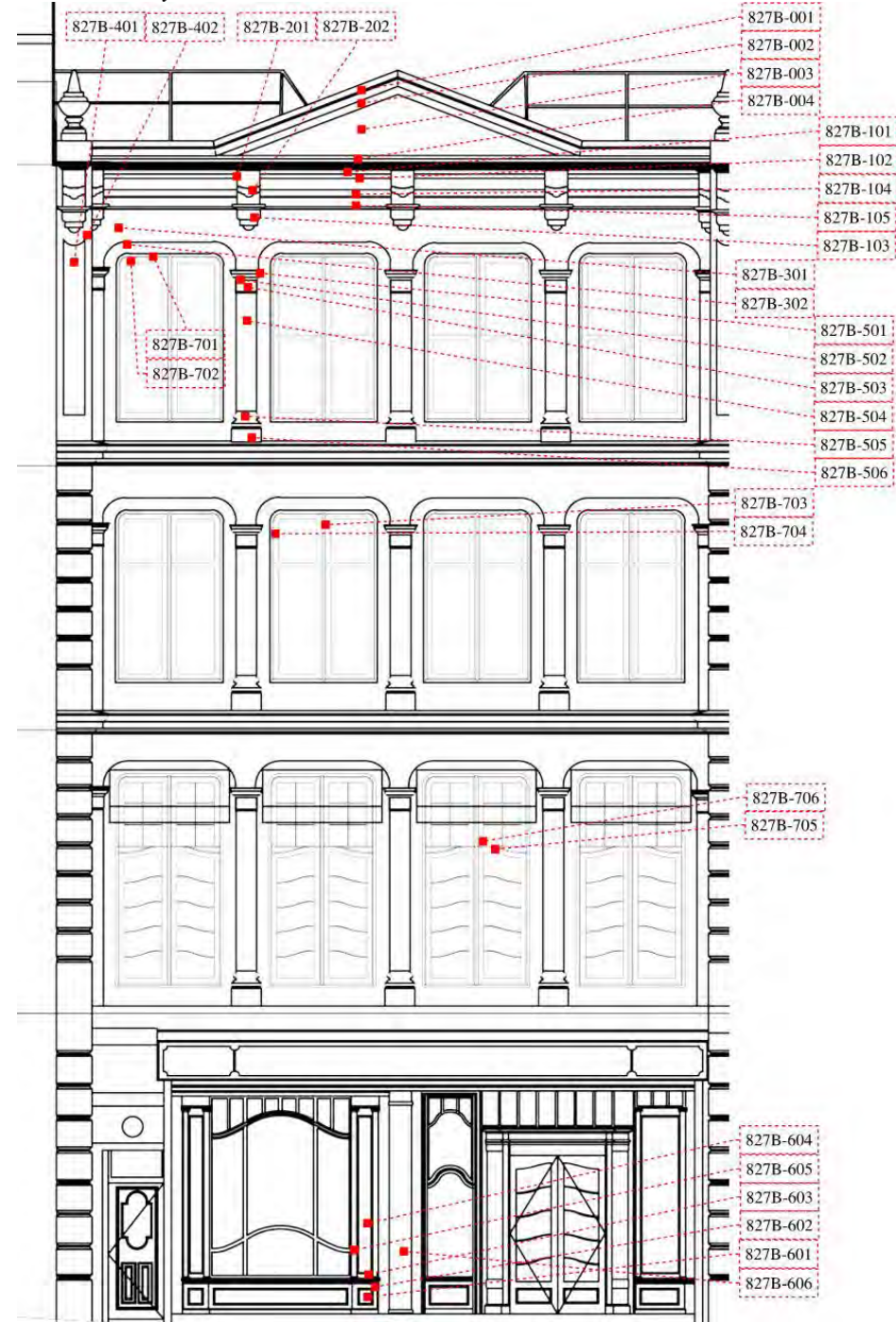

831 Broadway

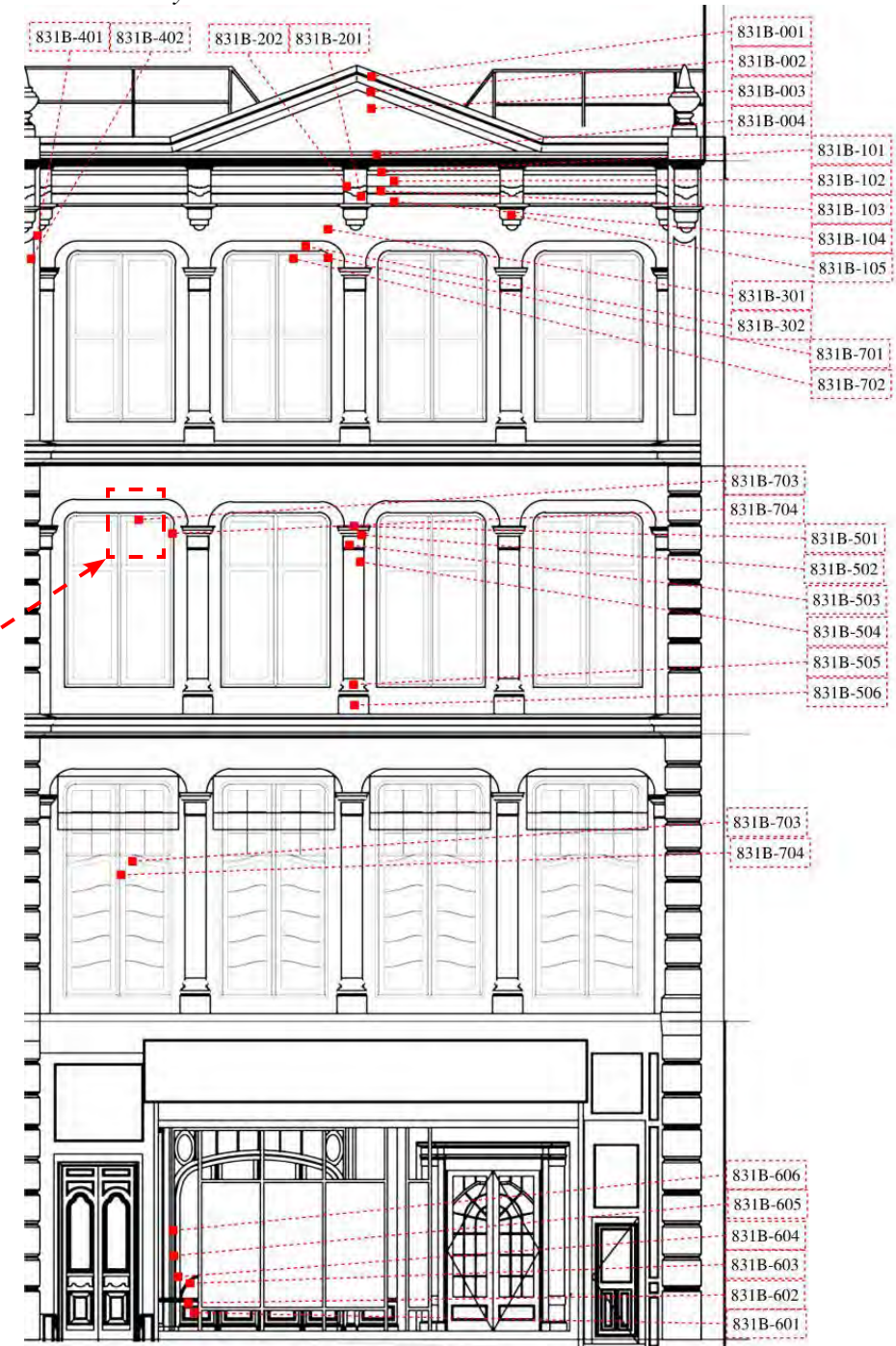

WINDOW SASH  
PAINT SAMPLES  
831B - 704

Jablonski Building Conservation, Inc.  
Architectural Conservators

December 6, 2017  
A-1

### SAMPLES AREAS - 827

Jablonski Building Conservation, Inc.  
Architectural Conservators

December 6, 2017  
A-2

### SAMPLES AREAS - 831

### 827-831 BROADWAY · FINISHES INVESTIGATION I-II

SCALE	As Noted
CLIENT	BH Quality Broadway Investors
PROJECT NUMBER	17.32
DATE	April 24th 2018



**DXA studio**  
894 6th Avenue  
5th Floor  
NYC 10001  
T 212 874 0567  
dxastudio.com

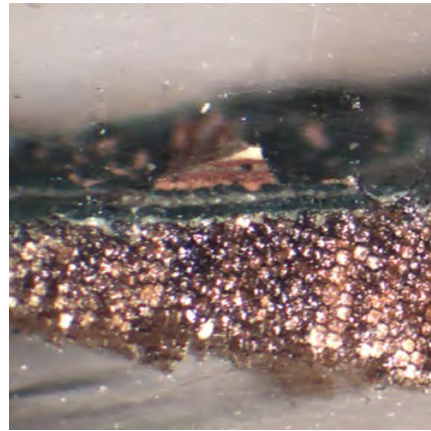

831B-703A Simulated Daylight

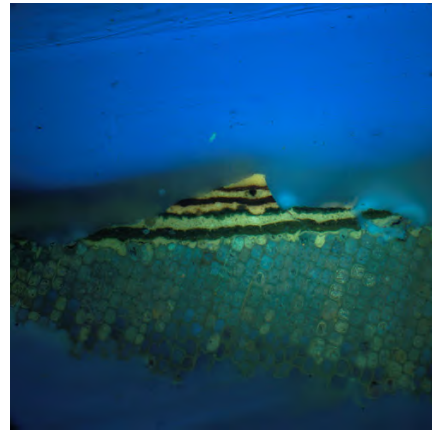

831B-703A Ultraviolet Light

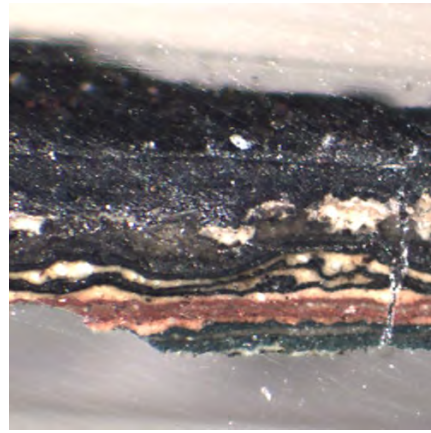

831B-703B Simulated Daylight

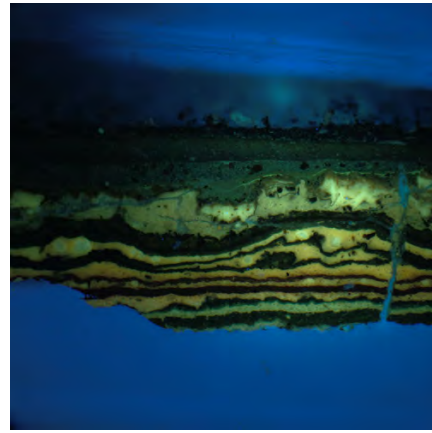

831B-703B Ultraviolet Light

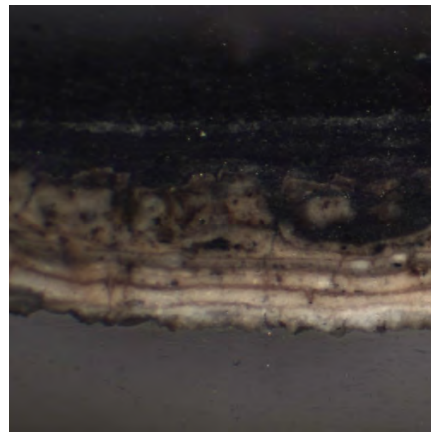

831B-704 Simulated Daylight

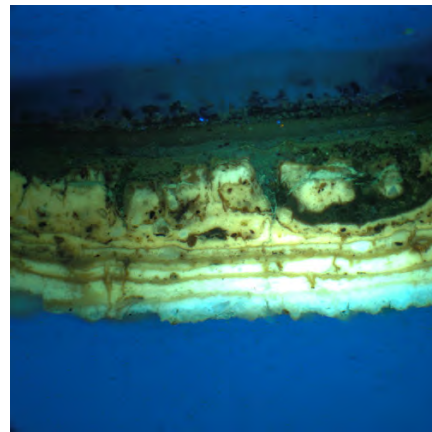

831B-704 Ultraviolet Light

**TYPICAL PAINT CHROMOCHRONOLOGY AND COLOR MATCH**

SAMPLE LOCATION AND NUMBER: 831B-703 Window, 3<sup>rd</sup> floor sash

SUBSTRATE: Wood

CHROMOCHRONOLOGY	PRIMER/FINISH	COMMERCIAL MATCH	MUNSELL MATCH
1. Yellowish white	Primer		
2. Dark green	Primer	1136-7	5G 3/2
3. Dark green	Finish		
4. Grey	Primer		
5. Green	Finish		
6. Orange	Primer		
7. Red	Finish		
8. Greyish red	Primer		
9. Red	Finish		
10. Yellowish white	Primer		
<span style="border: 1px dashed red; padding: 2px;">11. Black</span>	<span style="border: 1px dashed red; padding: 2px;">Finish</span>	<b>CIRCA 1940`S - 50`S - SASH COLORS</b>	
<span style="border: 1px dashed red; padding: 2px;">12. Yellowish white</span>	<span style="border: 1px dashed red; padding: 2px;">Primer</span>		
<span style="border: 1px dashed red; padding: 2px;">13. Dark green</span>	<span style="border: 1px dashed red; padding: 2px;">Finish</span>		
<span style="border: 1px dashed red; padding: 2px;">14. Black</span>	<span style="border: 1px dashed red; padding: 2px;">Finish</span>		
<span style="border: 1px dashed red; padding: 2px;">15. Dark grey</span>	<span style="border: 1px dashed red; padding: 2px;">Finish</span>		
16. Yellowish white	Primer		
17. Yellowish white	Finish		
18. Black	Primer		
19. Black	Finish		
20. Black	Primer		
21. Black	Finish		
22. Black	Primer		
23. Black	Finish		

**STOREFRONT & WINDOWS FINISH COLORS**



**PROPOSED COLOR;  
BLACK PANTHER  
2125-10**

Notes:

- Layers 14-17 are heavily deteriorated.

**PAINT PHOTOMICROGRAPHS OF  
WINDOW SASH PAINT SAMPLES**

**PAINT CHROMOCHRONOLOGY AND COLOR MATCH  
OF WINDOW SASH PAINT SAMPLES**





**SECOND FLOOR QUOIN USED FOR MICRO ABRASIVE TESTING WITH;**  
**1. CALCIUM CARBONATE Z5 GRAIN SIZE**  
**2. GARNET, 120 MESH**  
**3. CRUSHED WALNUT SHELLS, 35/60 MESH**



**TESTING IN PROGRESS**



**MICRO ABRASIVE TEST  
BEING CARRIED OUT**



**QUOIN AFTER TEST CLEANING**



**QUOIN PRIOR TO TESTING**



**QUOIN AFTER ABRASIVE CLEANING WITH CRUSHED  
WALNUT SHELLS AT 40PSI**

827-831 BROADWAY · MICRO ABRASIVE PAINT REMOVAL TESTING\_PHOTOS



**DXA studio**  
894 6th Avenue  
5th Floor  
NYC 10001  
T 212 874 0567  
dxastudio.com

**SCALE** As Noted  
**CLIENT** BH Quality Broadway Investors  
**PROJECT NUMBER** 17.32  
**DATE** April 24th 2018

**56**





EXISTING ELEVATION



PROPOSED ELEVATION

REMOVE EXISTING RAILING AND REPLACE WITH GLASS RAILING

CLEAN EXPOSED LIMESTONE WITH SURE KLEAN 942 LIMESTONE AND MARBLE CLEANER OR EQUAL. TESTING FIRST AND FOLLOWING MANUFACTURERS INSTRUCTIONS. WATER RINSE WITH FAN TIPPED NOZZLE AT NO MORE THAN 250 PSI (TYP.)

REMOVE PAINT FROM LIMESTONE USING PROSOCO ENVIROKLEAN SAFETY PEEL 1 OR EQUAL, TESTING FIRST AND FOLLOWING MANUFACTURERS INSTRUCTIONS (TYP.)

INTERACTIVE PLAQUE

REPAIR AND REPOINT LIMESTONE FACADE (TYP.) AND TRIM AS REQ. WITH RESTORATION MORTAR, TO MATCH EXISTING IN COLOR, TEXTURE, DETAIL, AND TOOLING, AND FOLLOWING MANUFACTURERS INSTRUCTIONS.

RESET AND REANCHOR DECORATIVE URNS AT CORNICE AND CORNICE BRACKETS, AS REQ. USING STAINLESS STEEL ANCHORS AND PINS AND RETAINING AND REUSING ORIGINAL MATERIALS.

REPOINT LIMESTONE FACADE AS REQ. HAND RAKE JOINTS AND REPOINT TO MATCH EXISTING IN COLOR, TEXTURE, COMPOSITION AND TOOLING (TYP.)

UPLIGHTING ON EACH COLUMN (TYPICAL), FIXTURE COLOR TO MATCH FACADE

REPLACE WINDOWS WITH PAIRED 1 OVER 1 - TYPICAL

REMOVE AWNINGS ON SECOND FLOOR WINDOWS

KEEP SECOND FLOOR WINDOWS AND JUILLETTE BALCONIES ON 827

RESTORE AND REPAIR EXISTING STOREFRONT ON 827

CAST STONE CORNICE TO MATCH SECOND FLOOR CORNICE PROFILE

PIN MOUNTED METAL LETTER ON METAL SIGN BAND WITH COVE LIGHTING

NEW PAINTED WOOD STOREFRONT ON 831

BROADWAY - EXISTING AND PROPOSED ELEVATIONS

827-831 BROADWAY · RESTORATION WORK

SCALE As Noted  
 CLIENT BH Quality Broadway Investors  
 PROJECT NUMBER 17.32  
 DATE April 24th 2018



827 STOREFRONT ALTERATED C.1981

EXISTING STOREFRONT

831 STOREFRONT ALTERED AFTER 827 AND AFTER 1981

SCRAPE, REPAINT AND REPAIR METAL BALCONIES AT 827, REATTACH LOOSE ELEMENTS AS REQUIRED, RESTORE MISSING PIECES TO MATCH EXISTING.

RESTORE AND REPAIR EXISTING STOREFRONT ON 827

EXISTING DOOR TO BE USED AS EGRESS



PROPOSED STOREFRONT

- UPLIGHTING ON EACH COLUMN (TYPICAL), FIXTURE COLOR TO MATCH FACADE
- CAST STONE CORNICE TO MATCH SECOND FLOOR CORNICE PROFILE
- PIN MOUNTED METAL LETTER ON METAL SIGN BAND WITH COVE LIGHTING AT BASE
- REPLICATE MISSING CAST IRON COLUMN TYP.
- NEW WOOD AND GLASS DOUBLE DOORS
- INTERACTIVE PLAQUE
- REPAIR AND REPAINT QUOINING IN HISTORIC COLOR
- NEW PAINTED WOOD STOREFRONT - TYPICAL

BROADWAY - EXISTING AND PROPOSED STOREFRONT ELEVATIONS  
827-831 BROADWAY · RENDERED STOREFRONT ELEVATIONS



**DXA studio**

894 6th Avenue  
5th Floor  
NYC 10001  
T 212 874 0567

dxastudio.com

**SCALE**  
**CLIENT**  
**PROJECT NUMBER**  
**DATE**

As Noted  
BH Quality Broadway Investors  
17.32  
April 24th 2018

**58**

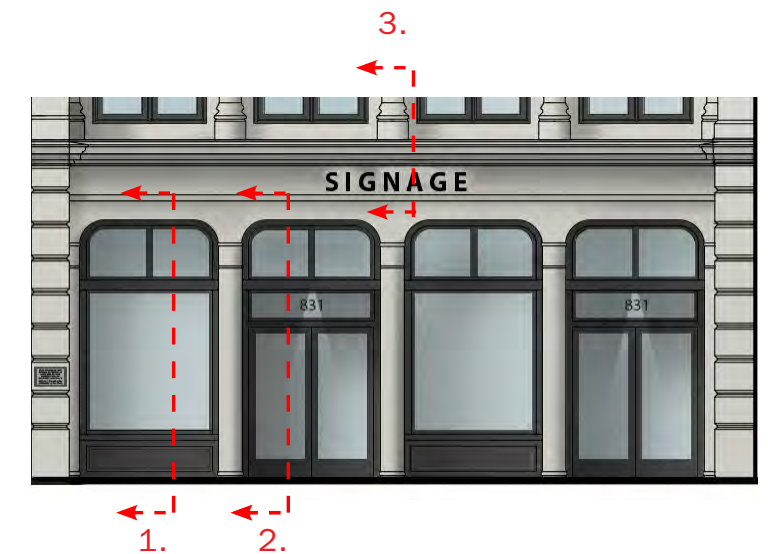
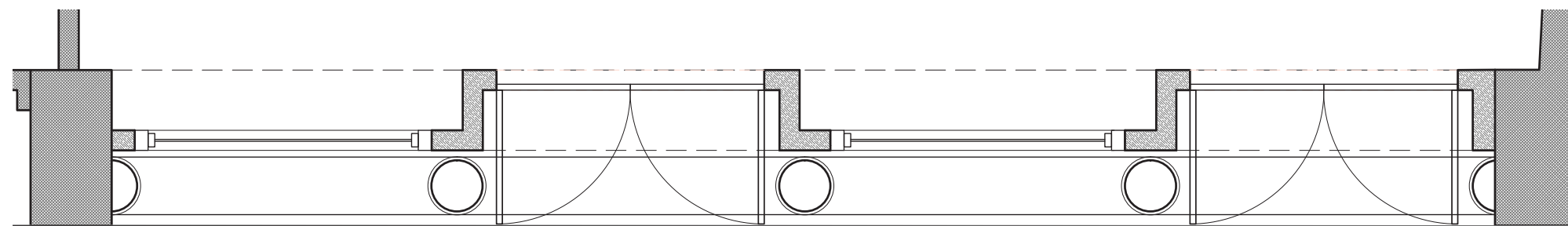
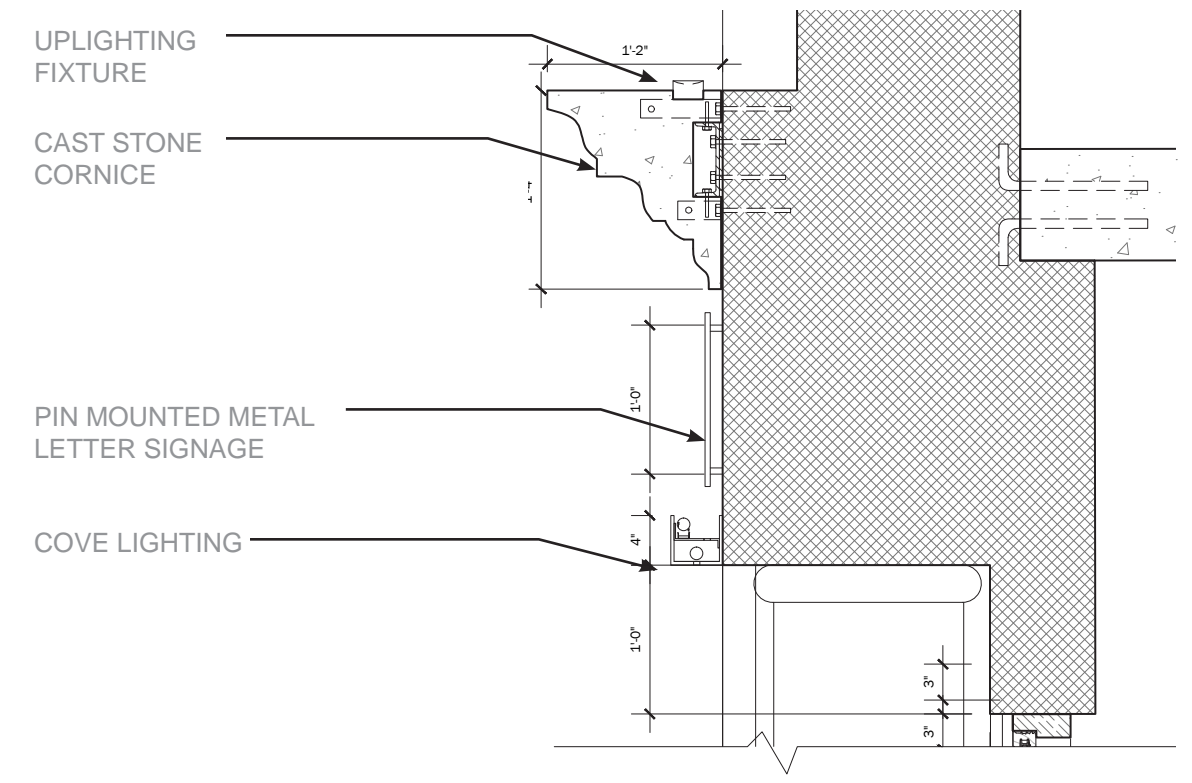
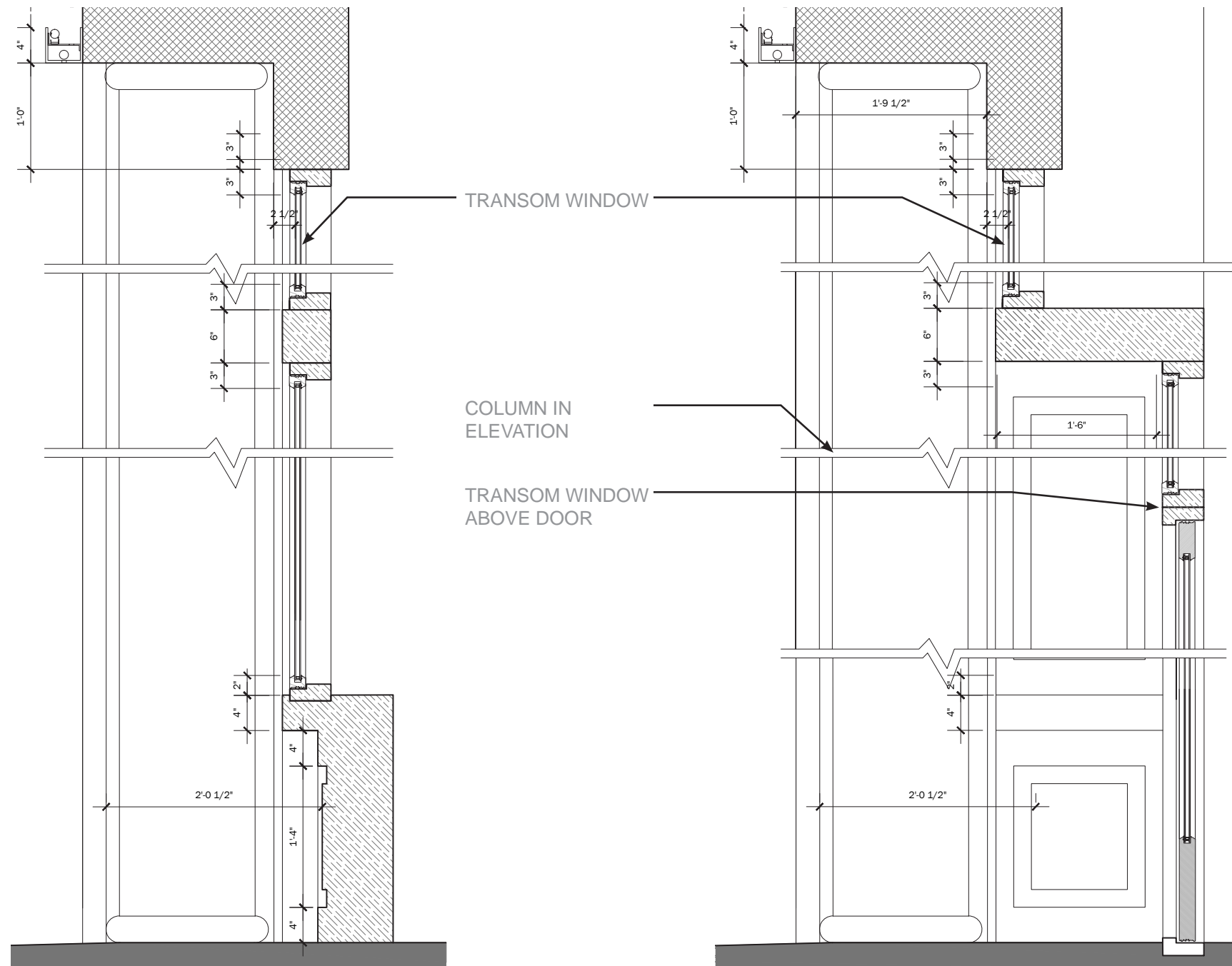

BROADWAY - 831 PROPOSED STOREFRONT SECTION DETAILS

827-831 BROADWAY · STOREFRONT DETAILS

SCALE As Noted  
 CLIENT BH Quality Broadway Investors  
 PROJECT NUMBER 17.32  
 DATE April 24th 2018





EXISTING ELEVATION

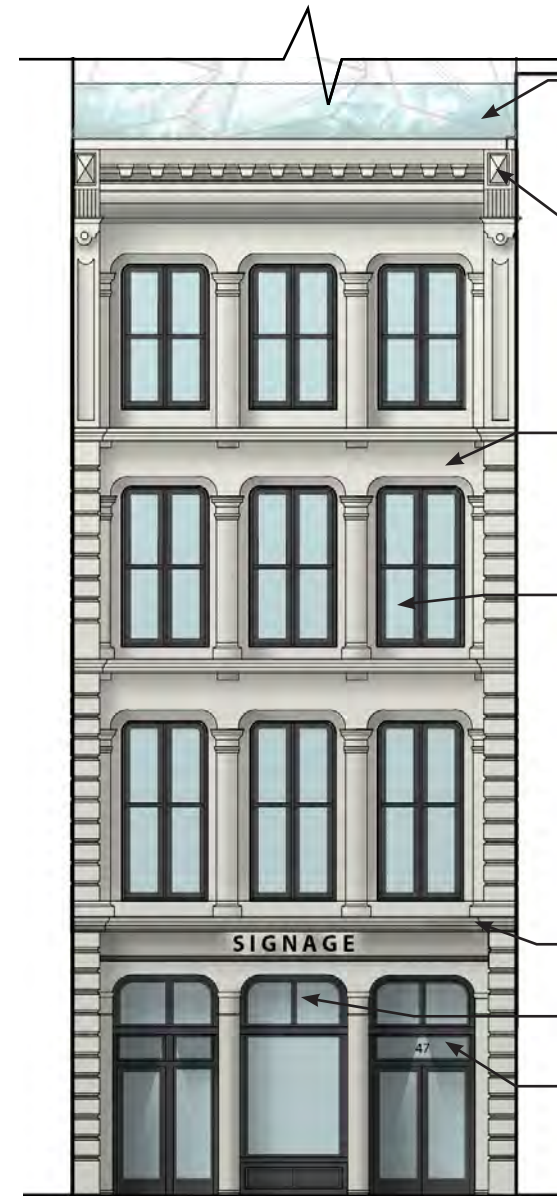

PROPOSED ELEVATION

- REMOVE EXISTING RAILING AND REPLACE WITH GLASS RAILING
- RESTORE AND REPAIR TO MATCH EXISTING CORNICES (TYP.), TRIM AND STONE FACADE
- REMOVE PAINT, CLEAN AND EXPOSE LIMESTONE IF POSSIBLE. FINISH TO MATCH BROADWAY ELEVATION (TYP.)
- REPLACE WINDOWS WITH PAIRED 1 OVER 1 - TYPICAL
- NEW CORNICE
- NEW SIGNAGE
- NEW WOOD STOREFRONT

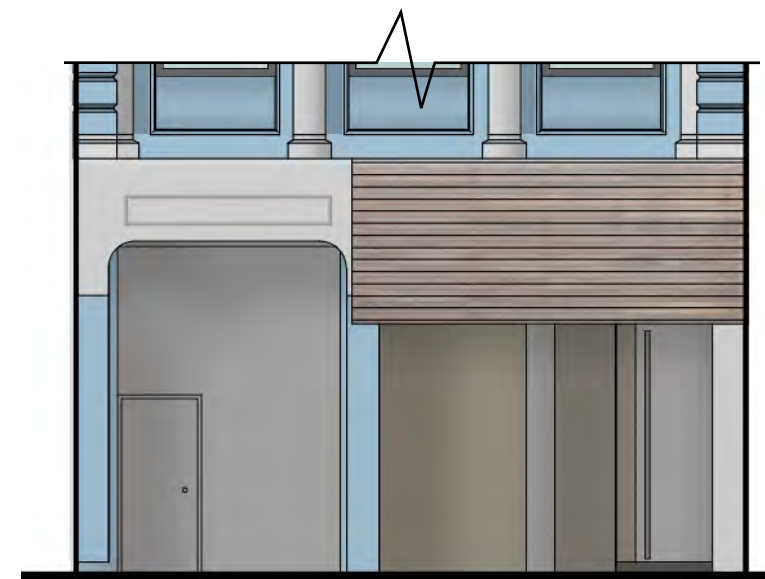

- NEW CORNICE TO MATCH HISTORIC
- NEW SIGNAGE ON TRANSOM FOR RETAIL
- EGRESS DOOR
- NEW PAINTED WOOD DOUBLE DOORS
- REPAIR AND REPAINT QUOINING IN HISTORIC COLOR
- NEW PAINTED WOOD STOREFRONT - TYPICAL

12TH STREET - EXISTING AND PROPOSED ELEVATIONS & STOREFRONT

(NOT DESIGNATED) · RESTORATION WORK

SCALE As Noted  
 CLIENT BH Quality Broadway Investors  
 PROJECT NUMBER 17.32  
 DATE April 24th 2018



**827-831 BROADWAY**

DXA studio

